



# [SYS]



## KINE[SYS]TEM

**FROM NATURE TO ARCHITECTURAL MATTER**

INTERNATIONAL CONFERENCES

JUNE 19<sup>TH</sup> - 20<sup>TH</sup> 2017, LISBON, PORTUGAL

**CONFERENCE  
PROCEEDINGS**

**ISCTE IUL**  
Instituto Universitário de Lisboa

PUBLISHER: DINÂMIA CET-IUL, ISCTE - INSTITUTO UNIVERSITÁRIO DE LISBOA  
EDITED BY MARIA JOÃO DE OLIVEIRA AND FILIPA CRESPO OSÓRIO



Publisher: DINÂMIA'CET-IUL  
ISCTE - Instituto Universitário de Lisboa  
All rights reserved.  
Instituto Universitário de Lisboa (ISCTE-IUL)  
Avenida das Forças Armadas, 1649-026 Lisbon, Portugal  
Tel. + 351 217 903 000  
<https://www.iscte-iul.pt>

Edited by Maria João de Oliveira and Filipa Crespo Osório.

© Kine[SIS]tem From Nature to Architectural Matter International Conference  
copyright in all texts, projects and images, are owned by their authors

Cover image: Maria João de Oliveira, "The sparkling shade"

This publication has its origin in the papers of the  
International Conference of KINE[SIS]TEM From Nature to Architectural Matter,  
curated by Vasco Moreira Rato and Maria João de Oliveira,  
that was held in Lisbon, from June 19<sup>th</sup> to 20<sup>th</sup> 2017.

Printed in Portugal

ISBN: 978-989-8862-24-2  
ISBN digital: 978-989-8862-25-9  
URI: <http://hdl.handle.net/10071/13603>

[kinesistem17.weebly.com](http://kinesistem17.weebly.com)





## Foreword

Architecture creates artificial environments that host human activities and mediate the interplay with nature. Traditionally, this dynamic interaction was assured by static strategies well established throughout the history of human settlements and anchored to local nature and culture. First generation technologies like mechanical heating and cooling, or electric lighting, brought a false sense of control that led to a progressive decline of the awareness of nature. Previously consolidated knowledge and paradigms have been upset by new challenges and opportunities coming from technological innovation as well as cultural developments that respond to new perceptions of the conceptions and relationship between natural and artificial environments.

The Anthropocene and subsequent eras explode limits between human and non-human existence. In the last thirty years we have seen nature become a tool, a model and now a culturally blurry definition.

Anchored in its relationship with inhabitability, Architecture evolves criteria typical of a mediator - between environmental concerns, cultural and social forms, material paradigms and innovation and the pleasure of invention and discovery of new tectonics of articulation.

How can architectural systems moderate across all these factors while attending to the varying expectations of response? This is the starting question for the Kine[SiS]tem'17 – From Nature to Architectural Matter International Conference. Kine[SiS]tem – From Kinesis + System. Kinesis is a non-linear movement or activity of an organism in response to a stimulus. A system is a set of interacting and interdependent agents forming a complex whole, delineated by its spatial and temporal boundaries, influenced by its environment. Today, the argument for a holistically responsible and relevant architecture requires very effective strategies that can respond in a multidimensional way.

The challenge ahead requires design processes that are built upon consolidated knowledge, integrate and co-develop innovative technologies and seek inventiveness on and in the articulation with so called natural systems.

Zero-energy buildings are a crucial desired part of architecture systems for the 21st century and solar radiation is one key factor in low-energy thermal comfort. Computational-controlled sensor-based kinetic surfaces are one of the possible answers to control solar energy in an effective way, within the scope of contradictory objectives throughout the year. To develop such shading systems, inspired by natural patterns and assuring a low-cost production is the objective of the summer school following the international conference. The Kine[SiS]tem'17 – Shading Systems Summer School will integrate master classes, design studios and prototyping workshops. The Master classes will cover four themes: Sustainability, climate and solar radiation; Nature-based parametric patterns; Performance-based design; Digital fabrication. The Design Studios will explore the use of Grasshopper, Ladybug and Honeybee as creative and technical tools, from simulation to prototyping 3D responsive architectural solutions.

The summer school is intended for students and professionals from different areas of knowledge – architecture, design, fine arts, engineering, and programming, who are interested in the process of design: from ideation to prototype.

We acknowledge all the researchers sharing their work in the conference and express our deep gratitude to the four distinguished keynote speakers for their invaluable contribution to this common reflection on new and exciting paths to achieve human inhabitable environment criteria while being in an intelligent, exploratory and responsive dialogue with the much larger and broader natural ecosystems.

**Vasco Moreira Rato**

ISCTE-IUL, ISTAR-IUL, Vitruvius FabLab-IUL

**Carla Leitão**

Rensselaer Polytechnic Institute, School of Architecture, Troy, NY, USA



## Scientific Committee

**Alberto Estévez Escalera** (IESARQ, Universitat Internacional Catalunya, Barcelona, Spain)  
**Andrea Pavoni** (DINÂMIA'CET-IUL, ISCTE-IUL, Lisbon, Portugal)  
**António Leitão** (Instituto Superior Técnico (IST-UL), Lisbon, Portugal)  
**Carla Leitão** (Rensselaer Polytechnic Institute, School of Architecture, Troy, NY, United States of America)  
**Cristina Veríssimo** (Dalhousie University, School of Architecture, Halifax, Canada)  
**Eliana Pinho** (Faculty of Architecture - University of Porto (FAUP), Oporto, Portugal)  
**Francisco Teixeira Bastos** (Instituto Superior Técnico (IST-UL), Lisbon, Portugal)  
**Kim Williams** (Director of the "Nexus: Relationships Between Architecture and Mathematics.")  
**João Pedro Xavier** (Faculty of Architecture - University of Porto (FAUP), Oporto, Portugal)  
**João Rocha** (Universidade de Évora, Évora, Portugal)  
**José Nuno Beirão** (CIAUD, Faculdade de Arquitectura, Universidade de Lisboa, Lisboa, Portugal)  
**José Pedro Sousa** (DFL, Faculty of Architecture - University of Porto (FAUP), Oporto, Portugal)  
**Manuel Couceiro** (CIAUD, Faculdade de Arquitectura, Universidade de Lisboa, Lisboa, Portugal)  
**Maurizio Giodice** (University of Rome - La Sapienza, Rome, Italy)  
**Michael Su** (Pratt Institute of Design GAUD, Brooklyn, NY, United States of America)  
**Michele Calvano** (AANT - Academy of Art and New Technology in Rome; University Sapienza of Rome, Italy)  
**Paulo Tormenta Pinto** (DINÂMIA'CET-IUL, ISCTE-IUL, Lisbon, Portugal)  
**Pedro Costa** (DINÂMIA'CET-IUL, ISCTE-IUL, Lisbon, Portugal)  
**Pedro Januário** (CIAUD, Faculdade de Arquitectura, Universidade de Lisboa, Lisboa, Portugal)  
**Philippe Baumann** (Pratt Institute of Design GAUD, Brooklyn, NY, United States of America)  
**Sancho Oliveira** (IT-IUL, ISCTE-IUL, Lisbon, Portugal)  
**Teresa Marat-Mendes** (DINÂMIA'CET-IUL, ISCTE-IUL, Lisbon, Portugal)  
**Vasco Rato** (ISTAR-IUL, ISCTE-IUL, Lisbon, Portugal) Scientific Committee Chair  
**Vera Viana** (Conference Report Editor na empresa Nexus: Relationships between Architecture and Mathematics)

## Organization Committee

**Bruno Vasconcelos** (ISCTE-IUL, DINAMIA'CET-IUL)  
**Carla Leitão** (Rensselaer Polytechnic Institute, School of Architecture, Troy, NY, USA)  
**Fátima Santos** (ISCTE-IUL, DINAMIA'CET-IUL)  
**Filipa Crespo Osório** (ISCTE-IUL, ISTAR-IUL)  
**João Pedro Sousa** (ISCTE-IUL, VFabLab)  
**Maria João Machado** (ISCTE-IUL, DINAMIA'CET-IUL)  
**Maria João de Oliveira** (ISCTE-IUL, DINAMIA'CET-IUL) Organizing Committee Chair  
**Maria José Rodrigues** (ISCTE-IUL, DINAMIA'CET-IUL)  
**Mariana Leite Braga** (ISCTE-IUL, DINAMIA'CET-IUL)  
**Sancho Oliveira** (ISCTE-IUL, IT-IUL)  
**Vasco Craveiro Costa** (ISCTE-IUL, IT-IUL)  
**Vasco Rato** (ISCTE-IUL, ISTAR-IUL) Scientific Committee Chair

# Index

<i>The Optimist's Guide to the Anthropocene</i> Manuel Kretzer	2
<i>Paste Matter 3D Printing in Monolithic Shells Fabrication Methods</i> Maria Teresa Bravo, Stephanie Chaltiel	10
<i>Material Dynamics: Shape Memory Materials in Dynamic Skins</i> Vera Parlac	19
<i>Origami Folded Surfaces: Kinetic Systems Behind the Folding</i> Filipa Osório, Sancho Oliveira	28
<i>Co-Habited, Co-Lived, Co-Designed and Co-Created Eco-Systemic Responsiveness in Systemic Approach to Architectural Performance: A Case Study on Interaction of Performative Solid Wood Envelope Ray and Algae</i> Marie Davidová	36
<i>Fabric Materiality FRP Shifting Towards Structures of Bio-Inspired Properties</i> Arielle Blonder	46
<i>Percolation Printing: Defining Volume Through Time and Viscosity to Create Non-Layered Volumetric Prints</i> Melanie Daguin, Sheila Lin, Oluwabunmi Fayiga	56
<i>Flips + Drips: Multi-Material Deposition Augmented Through Tactile 1:1 Volumetric Modeling</i> Ryan Barney, Lukas Lesina-Debiasi, Kevin Pazik	65
<i>Human Nature</i> Alex Haw	76
<i>Road Network Design with Space Syntax in Vendas Novas</i> Lázaro Ourique, Carla Patrícia Dias, Iolanda Fernandes	83
<i>Extreme cold conditions Architecture: An Antarctica's shelter prototype</i> Diogo Bulhões, Vasco Rato, Manuel C. Guedes	92
<i>Architectural Bionics: From Living Nature to Architecture</i> Dmitri Kozlov	102
<i>Responsive Spicule Systems: Simulation &amp; Alignment</i> Elias Darham	111
<i>Using Generative Design for Evaluating and Improving Energy Efficiency in Architecture</i> Catarina Rocha, António Menezes Leitão	121
<i>A Psychotropic Surface Based on Soft Shape Changing Material Emotional Input and Pneumatically Driven Actuator</i> Yann Blanchi, Elizabeth Mortamais	130
<i>The Impact of Digital Fabrication in Contemporary Portuguese Architecture: Witnessing Four Practical Cases</i> Susana Neves, José Beirão, João Rocha	137

<b><i>Digital Doubles, Colliding In Mid-Air</i></b> <b>Bob Sheil, Thomas Pearce</b>	150
<i>Human-inspired Seismic-controlling Autonomous Structures</i> Wilfredo Méndez, Esmeralda Niño	163
<i>Between the Shadow and the Geometry of Light: Hestnes Ferreira in continuity with Louis Kahn</i> Alexandra Saraiva	173
<i>Translating Algorithmic Design from CAD to BIM</i> Renata Castelo Branco, António Leitão	181
<i>A Chemical Paradigm: Matter behavior as heterarchical organizations to generate a design method for resilient city patch</i> Orkun Beydağı	191
<i>Origami Textures for Adaptive Plate and Shell Structures</i> Maurizio Giodice, Francesco Romeo	205
<i>Adaptability in the Built Environment Through The Use of Transformable Architecture: An exploration into the architectural why and engineering how</i> Mia Tsiamis, Ryan Haselman	216
<i>Musical Morphogenesis: A Self-Organizing System</i> Maria João de Oliveira, João Pedro Sousa, Vasco Craveiro Costa, Sancho M. Oliveira, Ana Mena	235
<b><i>Metabolic Architecture: Genetics, Digital Morphology, Turing, &amp; AI</i></b> <b>Dennis L Dollens, Alberto T. Estévez</b>	248
<i>Digital Fabrication in Education: Inside An Emerging Design Program</i> Louay Youssef	257
<i>Re-morphing the Amorphous: Creating New Urban Substance</i> Yannis Zavoleas	265
<i>A Study on the Materialisation and Formation of Mycelium in a Fabric Formwork</i> Gulay Elbasdi, Sema Alacam	275
<i>Growth as the Morphological Generator of Biological Identity</i> Ricardo Massena Gago	284
<i>Heliotropic Nature's</i> Mary Polites, Maddalena Belle, Marida Maiorino, Raquel Paramo, Brandon DiFalco, Carmo Cardoso	294
<i>Design as an Adaptive Time-Scape</i> Susannah Dickinson	305
<i>The Built Environment as an Extension Of Human Biology: Alexander, Damásio, Bratton</i> Diana Soeiro	314





SESSION 01  
 THE OPTIMIST'S GUIDE TO THE ANTHROPOCENE  
 Manuel Kretzer

*Paste Mattered 3D printing in monolithic shells fabrication methods*  
 Maria Teresa Bravo, Stephanie Chaltiel



*Material Dynamics - Shape Memory Materials in Dynamic Skins*  
 Vera Parlac



*Origami Folded Surfaces: kinetic systems behind the folding*  
 Filipa Osório, Sancho Oliveira



*Co-Habited, Co-Lived, Co-Designed and Co-Created  
 Eco-Systemic Responsiveness  
 in Systemic Approach to Architectural Performance: A Case Study  
 on Interaction of Performative Solid Wood Envelope Ray and Algae*  
 Marie Davidová



*Fabric Materiality FRP  
 Shifting towards structures of bio-inspired properties*  
 Arielle Blonder



*Percolation Printing - Defining volume through time and viscosity  
 to create non-layered volumetric prints*  
 Melanie Daguin, Sheila Lin, Oluwabunmi Fayiga



*Flips + Drips:  
 Multi-Material Deposition Augmented  
 Through Tactile 1:1 Volumetric Modeling*  
 Ryan Barney, Lukas Lesina-Debiasi, Kevin Pazik





## The Optimist's Guide to the Anthropocene

Manuel Kretzer

*"The humour of blaming the present, and admiring the past, is strongly rooted in human nature, and has an influence even on persons endued with the profoundest judgement and most extensive learning."*<sup>1</sup> (David Hume, 1777)

The world is changing rapidly. At least that's how it feels. Continuous technological innovation, disruptive scientific discoveries and new products on the market liquefy the state-of-the-art and often provoke a sense of insecurity and powerlessness. Such mental states, which may result in fear and a wish to return to previous times, are what Alvin Toffler already in 1970 described as 'future shock', the outcome of being exposed to "too much change in too short of a time." To prevent the extensive spread of future shock he demands "the conscious regulation of technological advance," which will restore order and stability.<sup>2</sup> Whilst the political and economical mandate to control any type of development and likewise preserve the past keeps gaining disturbing momentum, the question on how to address the uncertain progressively remains.

Ray Kurzweil, the director of engineering at Google and the author of numerous forward-thinking publications, provides an analytically grounded outlook into the future. Comparing the growth rate of various technological systems he predicts that continuously increasing computational performance and capacity will by 2045 lead to a state of Singularity, a point where progress will be so fast that it exceeds our ability to comprehend it, basically implying an infinite rate of change happening momentarily. Once this moment has been surpassed, mankind will merge with intelligent machines and through this surmount the biological restraints of its physical and psychological constitution.<sup>3</sup> According to Kurzweil, and many other "transhumanist" philosophers, this event will mark the next step of human evolution and radically transform life as we know it.

Yet similar types of exponential growth can also be witnessed in many other areas: Since the 1960s the world population has more than doubled, expanding from three to 7.5 billion people today, and according to a 2014 UN study is expected to rise to roughly ten billion by 2050,<sup>4</sup> amongst which 70% will be living in large megacities.<sup>5</sup> At the same time the average global life expectancy has in the last 100 years increased from 46 years of age in 1910 to 70 in 2014 and is supposed to exceed 76 by 2050.<sup>6</sup> For comparison in Germany we're currently looking at 81 years average life expectancy and by 2050 will be reaching 90 years and older. By then we might also

---

<sup>1</sup> J L Simon (ed), *The State of Humanity* (Blackwell, 1995), p3.

<sup>2</sup> Alvin Toffler, *Future Shock* (New York: Random House, 1970), 1, 428.

<sup>3</sup> Ray Kurzweil, *The Singularity is Near: When Humans Transcend Biology* (New York: Viking, 2005), 9.

<sup>4</sup> UN News Centre, "World Population projected to reach 9.6 billion by 2050 - UN Report," June 13, 2013, accessed Feb. 27, 2017, <http://www.un.org/apps/news/story.asp?NewsID=45165#.Ue0wn2Qmlql>.

<sup>5</sup> Mark Wilson. (2012). *By 2050, 70% Of The World's Population Will Be Urban. Is That A Good Thing?*. Available: <https://www.fastcodesign.com/1669244/by-2050-70-of-the-worlds-population-will-be-urban-is-that-a-good-thing>. Last accessed 27 feb 2017.

<sup>6</sup> Central Intelligence Agency, "The World Factbook, Country Comparison: Life Expectancy at Birth," accessed Feb 27, 2017, <https://www.cia.gov/library/publications/the-world-factbook/fields/2102.html>.





need 80% more energy than today,<sup>7</sup> consume up to 98% more food,<sup>8</sup> and will have more plastic in the ocean than fish.<sup>9</sup>

Obviously all these tendencies not only have an impact on our own species and our behavior within the larger structure of society but also on our planet's ecological system, its biodiversity, climate and atmosphere. Since this impact is actually considered to be so severe and irreversible, scientists are proposing to constitute a new geological epoch, the Anthropocene - the age of humans. Starting in the 1950s, with first atomic bomb testing, the Anthropocene marks a period throughout which the geological face of Earth has been largely defined by the effects of human activity.

With such prospects comes an immanent urge to develop new strategies that address the above stated tendencies, including globalization, ecological scarcities, techno-social connectivity and abundant technology and especially for us as architects a demand to create spaces and environments, which value young emerging generations, who strive for independence, self-expression and the celebration of their individuality and diversity within a quickly transforming landscape. But most of all the question arises on how to overcome our affinity with the past and our belief that everything was better in the old days?

Unfortunately however it's precisely our propensity for preservation, which stimulates the common misbelief that change can only be approached by fighting it. We're building dikes against rising sea levels, fences to keep those in need away from those who have, walls to preserve energy, to isolate, to exclude and to contain. Of course it's important to retain values, heritage, culture and the foundations of society. It's essential to pass these values on and retain trust in their universality. Yet in times of change even the most substantial and accepted principles require reconsideration, especially when it seems that most actions are targeted towards blocking symptoms instead of approaching their cause. Maybe it's finally time to stop fighting change and instead embrace it as a possibility from which something new can emerge.

Interestingly nature has a much more dynamic approach towards change. Nature doesn't build barricades but rather adapts and evolves. Nature flows and follows a path of minimal effort. Nature cherishes diversification as a means to learn and progress.<sup>10</sup> In that context, of transformation, mutation and adaptation, paired with a good portion of naive optimism and curiosity at what the future might behold, lies an opportunity to search for solutions that can adapt and that include rather than exclude.

In "Actions of Architecture: Architects and Creative Users", Jonathan Hill, Professor of Architecture and Visual Theory at the Bartlett School of Architecture in London, argues that historically there are three main strategies for achieving spatial adaptivity. The first one is based on spatial abundance, which means that a room is so big, that it can easily provide for a variety of uses. This approach becomes evident for example in the ballrooms of baroque palaces, which were not predetermined to certain actions or occupations but instead allowed for various uses and scenarios, like banquets, audiences, formal gatherings or other related events. A similar approach was developed during modern times, inspired by traditional Japanese housing, with the

---

<sup>7</sup> Kumi Kitamori. (2012). *OECD Environmental Outlook to 2050: The Consequences of Inaction - Key Facts and Figures*. Available: <http://www.oecd.org/env/indicators-modelling-outlooks/oecdenvironmentaloutlookto2050theconsequencesofinaction-keyfactsandfigures.htm>. Last accessed Feb 27, 2017.

<sup>8</sup> Maarten Elferink and Florian Schierhorn. (2016). *Global Demand for Food Is Rising. Can We Meet It?*. Available: <https://hbr.org/2016/04/global-demand-for-food-is-rising-can-we-meet-it>. Last accessed Feb 27, 2017.

<sup>9</sup> Graeme Wearden. (2016). *More plastic than fish in the sea by 2050, says Ellen MacArthur*. Available: <https://www.theguardian.com/business/2016/jan/19/more-plastic-than-fish-in-the-sea-by-2050-warns-ellen-macarthur>. Last accessed Feb 27, 2017.

<sup>10</sup> Stefan Hildebrandt and Anthony Tromba (1996). *The Parsimonious Universe: Shape and Form in the Natural World*. London: Copernicus. 22 - 34.



concept of the open plan. Le Corbusier's Villa Savoye, among others, exhibits a free floor plan, completely relieved of any load-bearing walls, which thus allows the space to be divided freely and only where aesthetically needed.

The second possibility is based on *mechanical transformation*, highlighting the use of mechanical kinetic systems to transform space either in an automated or human-induced way. One of the earliest examples of this idea is Pierre Chareau's Maison de Verre in Paris, built in between 1928 and 1931. The house contains a variety of flexible or mechanically movable elements, like sliding screens, rotating walls, or retracting staircases, which are used to dynamically divide and transform the internal space. But it was not until the 1960s and 1970s, with the rise of computers and cybernetics, that architects like Cedric Price began developing more complex visions of automated kinetic architectures. Price's concept of the Fun Palace, which he developed together with the cybernetician Gordon Pask, was supposed to be made from an unenclosed steel structure, with traveling cranes on its top that would constantly move and assemble walls, platforms, floors, stairs and ceiling modules to form a myriad of ever changing spaces for a large variety of activities and uses.

The third and last strategy is more of a *political statement*, often based on the active and creative engagement of the user. Yona Friedman refers to Konrad Wachsmann's space truss systems in combination with Kurt Schwitter's spatial artwork Merzbau, an installation made from gathering and combining random objects, when explaining his concept of Merzstrukturen. Friedman's Merzstrukturen are the idea of an architectural prototype providing a strong and stable framework and infrastructure within which the inhabitants can then construct their own homes according to their individual needs and ideas. Similarly the Dutch artist Constant Nieuwenhuys had the vision of a similarly dynamic model but more focused on the inhabitants' personal experiences, which he called 'situations'. Within his vision of 'New Babylon', a structure, without a master plan, Constant imagined the individuals, who'd be freed from labor by the merits of automation, to do whatever they pleased, determined only by the power of their imagination and creativity.<sup>11</sup>

Albeit the above described approaches, individually or in combination, already provide for a large variety of possibilities and ideas, we are now at the brink of adding one more possibility to the list: *adaptivity through adaptive materials*. Such materials, which are also referred to as smart or active materials, can change their shape or their color, produce light or electricity, store heat or water or even adjust their surface texture. Equally striking as their active properties however is their purely synthetic constitution and their precise creation at a scale, which has formerly been unthinkable. For the development of dynamic architectural environments these materials offer various advantages over conventional technologies. Systems that would usually consist of a multitude of interlinked rigid parts can, due to the holistic setup of the materials, be seriously simplified, reducing engineering complexity, fabrication costs, maintenance requirements and increasing the overall comfort and energy efficiency of a building. Yet most importantly, they have the potential to encourage new types of sensual interaction and physical exchange with the environment and amongst others and us.

However, despite a growing interest in the performative aspects of this kind of materiality, most spatial scenarios are still rather traditional and fall far from exhibiting any of the radical opportunities that these materials offer, which is due to a number of reasons:

Firstly, many of the materials are still technologically immature and often not developed with respect to architectural applications. The few materials that actually are available as finished products, usually have not only rather narrow properties, since they are always designed for a very specific purpose, but most likely also limitations in scale and durability. This is mainly a problem of generating interest and demand within the creative community and consequently propelling the development and production of appropriate materials.

---

<sup>11</sup> Jonathan Hill, *Actions of Architecture: Architects and Creative Users* (London: Routledge, 2003), 30-34.



Secondly, there is a big gap in between architecture and science, which means that the amount of information on new material developments, which is communicated in a way that can be comprehended without having expert knowledge or insights, is very constrained and often scientifically mystified. Whilst the first issue can be regarded as something that might be solved economically, this problem is rooted largely in non-compliant means and ways of communication, a diverging understanding of various terms such as scale and time, and most of all a lack of exchange and collaboration across the disciplines.

And lastly, and maybe even most importantly, there is a lack in ideologically distinguishing adaptive materials from traditional ones, which means that their defining dynamic properties are either constrained by forcing them onto existing structures and systems, or even neglected by standardizing and categorizing them in order to make them comparable to non-active materials and include them in existing databases and catalogs. Hence what needs to be developed is a new material toolset allowing for comparability whilst emphasizing an active material's time-related four-dimensionality.

To mediate a more comprehensive understanding of these thoughts to my students I try to run explorative and playful courses throughout which I want to highlight the importance of a process oriented model. On the one hand this involves encouraging the students to physically experience the functionality of selected materials, comprehend their working principles and composition and understand the relationship between fabrication procedures and materials' performance. On the other hand it means to animate them to think design in terms of dynamic processes, as something that is developed and that evolves, and not as a the result of a preconceived idea or the sum of isolated facts.

Returning to the initially posed conflict of facing tremendous global change but understanding this fact as a potential to create novelty, I will now present a few results from an experimental studio that I ran at the Dessau International Graduate School of Architecture in fall 2016 together with my colleague Adil Bokhari, which was an attempt to approach the unknown from a radically optimistic perspective. The course was organized into three phases. During the first part, the students, who worked in groups of two, performed extensive research into various contemporary tendencies, their cause, current state and possible further progression, including air pollution, littering, deforestation, space exploration, depression and the rise of seawater levels. The most important aspect of this part was to understand these issues from an objective and unbiased point of view, neglecting any sort of romantic associations that might otherwise occur. To conclude their findings the students generated highly detailed imagery of speculative future scenarios, optimistically blurred visions of drastic global developments (Fig. 01).



Figure 1. Lim Tian Jing and Leong Chee Chung – Amazonas city, all trees replaced by buildings.

Whilst this was an incredibly difficult yet astonishingly liberating task a second track was opened, the detailed physical study of material logic and behavior through hands-on experimentation. Over the course of six weeks the students thus looked into the logic and dynamics of particle aggregation, magnetic fields, non-newtonian fluids, smoke and the growth of crystals. This switch in between the macro and the micro level, in between theoretical speculation and practical exploration, prepared the groups to approach the final phase, the synthesis of both strains into physically graspable architectural proposals. A particular task was to focus on the spatial and sensual experience of the user and on the atmosphere of their newly developed architecture within the context of a radicalized global phenomenon.

Lim Tian Jing and Leong Chee Chung for example took on the topic of deforestation, which, as shown in Fig. 01, was exaggerated up to the point where they imagined that all trees on the planet would have become extinct and instead replaced by man-made buildings. Within this speculative context the group began wondering about the impact this effect would have on the ground and concluded that soil would most likely turn into some sort of dry land that might occasionally get flooded and then become mud and swamp. Next they posed the hypothetical question: "What if the solidification of that mud and the forms it is capable to create could be controlled?" Conducting intensive literature research into programmable matter, which refers to materials that have the ability to change their physical properties, such as shape, density, conductivity, opacity, etc., in a controlled and direct way,<sup>12</sup> as well as electro rheological fluids, which are liquids that harden when exposed to an electrical field, they eventually started experimenting with non-newtonian fluids. These fluids, which can be prepared by mixing cornstarch and water, have the interesting properties of remaining viscous as long as they are in their relaxed state but solidifying when exposed to mechanical pressure (Fig. 02).

---

<sup>12</sup> Tommaso Toffoli and Norman Margolus, "Programmable Matter: Concepts and Realization," *Physica D: Nonlinear Phenomena* Vol. 47 Issues 1-2 (1991): 266.

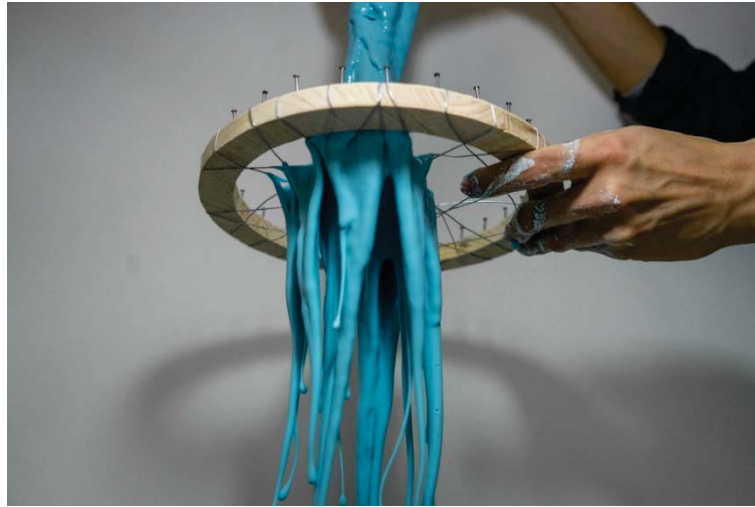

Figure 2. Lim Tian Jing and Leong Chee Chung – Exploring the intrinsic behavior of non-newtonian fluids.

During the last stage of the studio the group merged the previous explorations into a dynamic architectural scenario, based on a hypothetical material and structure that could be both soft and solid and which would allow the architecture to constantly transform and rearrange itself depending on desired use and occupation (Fig. 03 - 04). Unlike Cedric Price's idea of the Fun Palace however, which is a mechanically overloaded mega structure, their concept was fluid and dynamic like a living organism. The playfulness and joy exhibited in their imagined spaces and related activities combined with a focus on bright colors in their representation became so powerful, convincing and even desirable that their scenario easily succeeded in overcoming the terrible starting point the group set out with.



Figure 3. Lim Tian Jing and Leong Chee Chung – Section through proposed architectural scenario.





Figure 4. Lim Tian Jing and Leong Chee Chung – Perspective of proposed architectural scenario.

Pardis Zarghami and Hossam Elbrashi were the only group who chose a non-ecological challenge as their point of departure, the issue of depression, understood as a quickly growing global problem resulting from increased stress and pressure within our professional and personal lives. When researching the topic, its cause, effects and various consequences in depth, they learned that, albeit depression is generally treated as a mental disease, depressed people exhibit increased sensibility to the environment and at times outstanding peaks of creativity and productivity. To approach their task as objective as possible the group developed a two-dimensional matrix mapping psychological states and feelings onto architectural qualities such as texture, light, openings, color, scale etc. They then took that matrix and went through the cycle of a full day, trying to understand how personal emotions and related spatial desires vary over time. In parallel, just as all the other groups, they examined a certain material, in this case the behavior of Styrofoam when exposed to acetone, which melts the material and creates cavities and holes. The findings from both methods were eventually used to develop a parametric catalog of spatial qualities related to the different states of depression (Fig. 05).



Fig. 05: Pardis Zarghami and Hossam Elbrashi – Catalog of different spatial experiences.

In addition to the idea of combining the various spaces into logical sequences that in their unison form a large building structure (Fig. 06), they proposed that the individual tenants, depending on their current condition and desires, could personally transform and adapt their spaces according to specific preferences, very much like Constant's or Friedman's concepts. Yet rather than suggesting an additive process, where people bring something into an existing infrastructure, their idea is based on a subtractive process, where everything required is already existent but simply needs to be shaped into the right form.

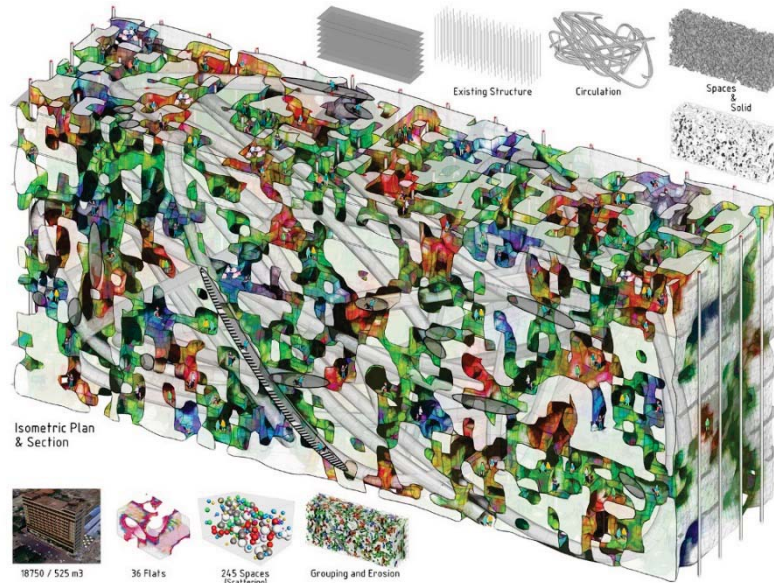

Figure 6. Pardis Zarghami and Hossam Elbrashi – Isometric plan and section.

Concluding this paper I must say that at times not only the students but also Adil and myself struggled with our self-assigned task, departing from what we see and what we are being taught and aiming at treating the devastating issues we're facing with humor and self-critique. However I think that even though the presented ideas might seem far from our reality and have various issues that at least for the time being will prevent their practical applicability, we managed to overcome the prevalent course of developing dark and disturbing dystopias, but instead created pleasant and encouraging concepts, which carry seeds of hope and joy. Especially for us architects I believe an optimistic look at the future, trust in our human capabilities and the willingness for collaboration is fundamental since we are the ones who define the spaces and environments of our future and we have to design the Anthropocene as we want it to be.

*"It is a mistake to think you can solve any major problems just with potatoes."*<sup>13</sup> (Douglas Adams, 1979)

<sup>13</sup> Douglas Adams (1979). The Hitchhiker's Guide to the Galaxy. Pocket Books. ISBN 0-671-46149-4.



## Paste Matter 3D printing in monolithic shells fabrication methods

Maria Teresa Bravo<sup>1</sup>, Stephanie Chaltiel<sup>2</sup>,

<sup>1, 2</sup> Institute of Advanced Architecture of Catalunya, <sup>2</sup> Universidad Politecnica de Catalunya

<sup>1</sup>[maite.bravo@iaac.net](mailto:maite.bravo@iaac.net), <sup>2</sup>[stephanie.chaltiel@iaac.net](mailto:stephanie.chaltiel@iaac.net)

**Abstract.** Fabrication methods with 3d printing for monolithic shells remain largely unexplored, in terms of the technologies implemented to ensure the integrity and the essential continuity of the structure during the construction phase. This crucial condition is directly related to the matter implementation during the fabrication process, which is further exacerbated when materials are applied in wet stage (such as concrete and clay mixes), including the proper composition of the material, the support system chosen, the placement protocol, and the deposition techniques, among other factors.

This paper features some case studies of material deposition in clay mixes for monolithic shells using robotic extrusion and spraying, aiming to identify critical aspects required for its correct execution, with an emphasis on its transformation during the construction process. The use of different digital technologies was explored, including 3d scanning, Rhino 3d, Kuka prc (interface kuka robotic arm to Rhino through a Grasshopper plug in), exposing different ways of creating robotic trajectories for the correct deposition of the material.

**Keywords.** *Real Time Control, Monolithic Shells, Robotic Fabrication, Clay Mix, Paste Matter.*

### Paste Matter and Robotic fabrication

Additive manufacturing often referred as 3D printing, is now implemented at diverse scales and techniques using paste matter. Among them, robotic fabrication is taking a relevant place, and significant amount of academic testing in the physical fabrication of paste like structures using robotic arms have been published over the past five years, where two main strategies can be found: extrusion and spraying.

Extrusion is conducted through a nozzle by which the paste like material is deposited by layers in a continuous manner, achieving complex geometries, but heavily restricted to the size and characteristics of the deposition apparatus.

*Enrico Dini* has played a significant role in large scale 3d printing with a sand based structures printed layer per payer in a giant CNC machine called *D Shape*, and was able to 3d print layer by layer a resulting structure of more than 2 m high. Also *Contour Crafting/CRAFT* developed by *Dr. Behrokh Khoshnevis* of the University of Southern California USC is a remarkable initiative investigating NASA 3d printing construction strategies in the Moon. Lately, the University of Montpellier has constructed a large scale concrete extrusion 3d printer. Many other initiatives in 3d printing concrete extrusion are blossoming during recent years in several locations, developing for buildings parts, systems, or entire houses.

Some important initiatives in clay extrusion include *Andrea Graziano "Co-de-it"* in the *"inFORMed clay matter"* research project, that explores 3d printing using a 6-axis robotic arm. Extrusion for 3d printed objects is under investigation in the research *"G Code Clay"* (by *Rael San Fratello*) using various clays (porcelain, bmix, terra-cotta, and recycled clay). The Italian firm *Wasp* works with a clay mix (clay, sand, and fibers), for their recent large-scale experiments. Since 2010, students from *laac* (Institute of Advanced Architecture Catalunya) started to fabricate with DIY systems by hacking existing robots extruders to produce some small geometrically provoking raw





ceramic structures, achieving link CAD programs such as Rhino with the robotic arm trajectory. In 2011, the first notable clay mix experiments resulted from laac where an extruder was connected to an industrial Kuka robot, achieving a freedom of geometry that has contributed to give the impetus to further experiments in the academic world.

Spraying is a technique that deposits material through a nozzle under pressure; able to 3d print with robotic arm piped to a paste of cement or clay that is simultaneous drying while printing in the air. Spraying has a long history using shotcrete (both wet and dry concrete mix), widely used in a variety of construction applications including civil works, pools, and buildings (Gedeon, 1993). This work presents some opportunities for the automatization of its placement, as seen in the work in 2016 from AA Visiting School in Stuttgart, where robotic spraying with fabric formwork was tested. Mud digital fabrication using spray is only recently being explored, and has influenced and shaped many workshops, like the Smart Geometry preliminary experiments from the AA visiting school Lyon (co-led by S.Chaltiel and MP.Placais in collaboration with Wilfredo Carazas earth aspecialist from CRATerre laboratory) from 2012 to 2015 at the Grands Ateliers de l'Isle d'Ábeau.

Despite that the findings of these ongoing experiments could be considered modest and incipient, the appearance of digital technologies unveils a potential use of 3d printing techniques for monolithic mud shells construction. This paper explores the suitable methods and protocols for its implementation, introducing different kind of paste mixes and techniques of 3d printing at large scale that are currently happening within robotic fabrication. The focus will be placed in comparing additive manufacturing versus other methods that include extruding on a surface and in the air, and spraying on light temporary formworks with clay mixes for the fabrication of monolithic shells.

## Paste Matter 3d printing methods

The main experiments that have emerged in 3d printing in paste matter can be grouped in two main families: deposition and spraying. The deposition technique has been explored in a wide number of developments, and it's perhaps the wider range of examples. However, the spraying technique remains still an unexplored and incipient practice. Three case studies will unveil some experiences of using extrusion and spraying for mud constructions,

## Dataflow between matter properties, code logics and robotic control

One of the most critical aspects to investigate in 3d printing is the link between three aspects: matter properties, code logics and robotic control. These aspects will be studied on each case study under the following elements:

1. Matter properties: Includes paste like material elements and characteristics (mud, plastic or concrete).
2. Machine control: Is defined by the feeding device that provide a storage container, feeding line, etc. A deposition apparatus that must contain the proper orifice to allow for the smooth passing of paste like materials in a controlled manner. It must contain a control mechanism (such an on-off control), or pressure/volume control. As the robot needs a deposition apparatus to deposit the material, a custom designed artifact must be provided. The width of deposition is typically defined by the perforations of the apparatus. The velocity is deducted from preliminary tests to establish optimum conditions.
3. Code logics. Includes the interface between digital and analogue. The first phase includes generating the 3d mode of the final form in a CAD software, such as Rhino or Grasshopper plug-in for Rhino. Includes the robotic data-flow of the interface with the robot is by using Kuka PRC. A responsive element could provide a sensor or scan to collect information in real-time that be feed into the control mechanism, and is typically done using Agisoft, or other suitable sensor.



## Case studies selected

The following case studies examine different strategies for these critical elements:

- 1) Extrusion with other material without formwork: *Mataerial*.
- 2) Spray in clay with temporary formwork: *Mud, Textiles and Robots*.
- 3) Extrusion in clay without formwork: *Pylos*.

## Case Study 1: Extrusions in the air 'Mataerial'

Project: *6 months research program at IAAC (Spain) & Studio Joris Laarman (Holland). 2013.*  
Title: *"Mataerial"*  
Students: *Petr Novikov, Saša Jokić.*  
Tutors: *Joris Laarman Studio.*

This antigravity experiment is based on the robotic extrusion in the air without any need for formwork or base material, and independent of the orientation. This innovative method can be described as "extruders with different material mix are dried by the robot at the same time as the material is being extruded allowing gravity performance. Like a 3d pen the structure can be 3d drawn in the air" (laac, 2014).

### Material properties

Two mixes were used and provided by Exon. A plastic mix composed of Epoxy thermosetting polymers diluted with marble powder (mix A), and a chemical instant reaction to dry instantly (mix B). Two tanks containing the separate mixes were connected to the robot and merged into 1 while being extruded.

### Machinic Control

The feeding device was a unique motor pushing on the mix under constant force. The deposition apparatus included a custom made pistol. Because the material dries in 1 sec., a hot air fan is also part of the end effectors of the robot. Only the on and off command of such system can be controlled computationally. The width of the deposition was 15 mm, reaching a velocity of 7cm per sec.

### Code logics

The interface with a kuka robot control through a cad program by writing a code / processing. Robot's Language called "Rapid Pod". The robotic data-flow did not include a responsive element.

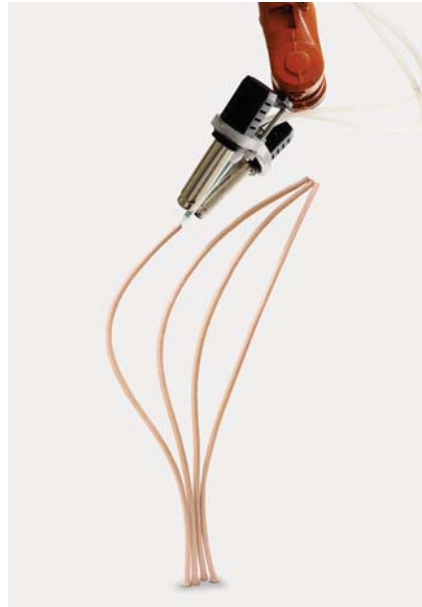

Figure 1. Plastic mix robotic extrusion creating gravity defying structures. Source: <https://www.dezeen.com/2013/05/17/mataerial-3d-printer-by-petr-novikov-sasa-jokic-and-joris-laarman-studio/>

## Case study 2: Robotically sprayed mud shells

Event: 4-days workshop. Gothenburg, Sweden. April 2016.  
Cluster: "Mud, Textiles and Robots for large structures"  
Participants: 10  
Cluster's tutors: S. Chaltiel and A. Dubor.

Two 3d digital fabrication workshops have allowed the exploration of robotically sprayed earthen shells, where the size of the resulting structure has proved to be larger than the average academic tests on robotically extruded clay mix. Earthen shells were built using willow branches arches with temporary pulled lycra fabric and iterative applications of robotically sprayed clay mix. Three resulting structures were fabricated ranging from 1m to 2m high, with a base of 1m x 2 m. The formwork set-up was in clusters of 2 or 3 willow branches forming peripheral arches and inside area of the structure fixed to a plywood base surface with drilled holes to insert the bending rods. Pulled elastic lycra fabric on bending rods.

### **Material properties**

The clay mix came from Barcelona (extracted from Terruel), because clay mixes are not easy to buy in any countries earth construction is not well known. The clay mix was applied in layers with the following proportion:

- Mix "Base": 1Unit (U) clay, 1U hard sand.
- Mix "Fibra 1": 1U cay, 1U sand, 1U fibres.
- Mix "Fibra 2": 1U cay, 1U sand, 2U fibres.



### ***Machinic Control:***

The deposition apparatus composed of two feeding devices: a Wagner heavy paint sprayer Flexio 590 HVLP with external Wagner air compressor (kit) used only for the “Base” clay mix (1er. layer). For all other layers, a “Sablon” manual concrete sprayer was used to spray the clay mix containing fibres (Fibra 1 and 2), of approx. 20 cm size, made of stainless steel. The spray cones could be varied by hacking and 3d printing some custom made nozzles made of a little boards containing 3 holes, with a new board with larger 3-2 cm diameter holes was laser cut to allow more material to be sprayed.

Calibration of the distance between nozzle and fabric formwork was tested and 20 cm was elected as the best homogeneous finish. The sprayed areas on the temporary fabric formwork were a circle ranging from 20 to 30 cm diameter, and the nozzle end point was placed at all times of the trajectory 30 cm away from the structure

The velocity of deposition was 5m/s as a constant.

The drying time in between each sprayed layer was 3 to 5 hours working indoors.

### ***Code logics:***

The robotic data-flow is with 2 kuka Agilus of 1 m reach, controlled through Kuka Prc Grasshopper. The responsive element includes 3d scanning, with Agisoft PhotoScan software (evaluation version) from a series of pictures taken from all sides of the structure after placing the structure in a highly contrasted environment. Export Scan to 3d model: The resulting mesh directly from 3d scan contains too many triangles and is formed by too many unattached parts, therefore in order to be usable the mesh needs to be simplified and closed. Grasshopper plugin for Rhino is used to decrease the density of triangles and join them, with the logic of using point proximity command to merge them. The 3d model Optimization using Karamba (plugin for Rhino) simulations are used to optimize 2 main issues: 1) to vary the shell thickness precisely to use the minimum amount of material, and 2) To achieve auto-stability and integrity of the structure. The logic was to include in the plug-in some characteristics of the clay mix with a similar Young modulus that in the material used (Ecoclay).

The final re-adjusted spray was done after the structures were 3d scanned twice: 1) Once when the structure was just ready with the fabric formwork and willow branches, and 2) After the application of the first 2 layers. The final robotic spray trajectory was then readjusted. The final thickness of the structure was 2cm.

Drying to reach setting time: in between each coating it's important to wait for the structure to dry enough to continue applying the next layer. When the applied clay layer is still wet, some strips of jute need to be layered to act as reinforcement. Those will overtime merge the with the clay mixes of the different layers, so they are lost formwork. In between layers the usual drying time is around 5 hrs. However, due to time constrains, the process was slightly accelerated with a manual hair dryer, which brought down the drying time to 3 hours in between layers. The removal of the temporary or loose formwork is once the structure reached sufficient thickness in proportion to its height.

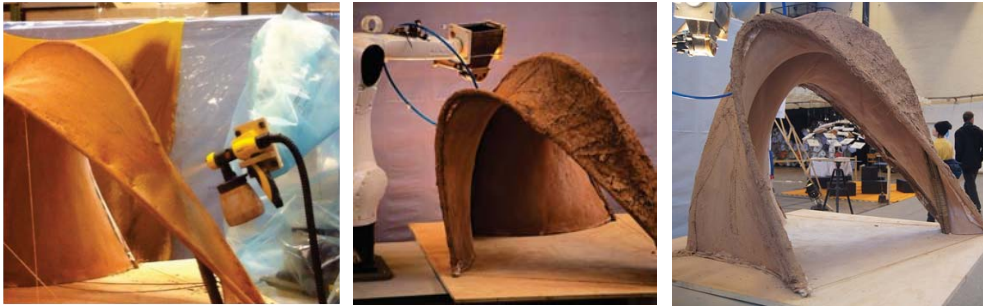

Figure 2. Wagner heavy paint sprayer connected to the Agilus Kuka robot containing clay mix and spraying on the earthen shell in progress. Smart Geometry 2016, Gothenburg, cluster Mud, Textiles and Robots. Photos by the workshop's participants.

A possible reference to continue evolving these academic tests would be to include some experiments from Foster and Partners team on the evolution of Enrico Dini D Shape 3d printer to print on Mars using temporary inflatable formwork to deposit the concrete mix.

### Case Study 3: Clay extrusion 'Pylos'.

Open Thesis Fabrication Iaac Program. 6 months research . 2014

Title: *Pylos*

Researcher: *Sofoklis Giannakopoulos. Cooperation with Enrico Dini and Slow Life project.*

Research advisor: *Areti Markopoulou*

Robotic expert: *Alexandre Dubor*

Computational expert: *Rodrigo Aguirre*

This experiment of 3d printed unbaked clay matter aims at achieving a high degree of sustainability in the use of material using robotic extrusion with different variables. Different columns like structures ranging from 0,7m to 2,0 in height were built, with different geometries printed as a continuous layer-by-layer robotic extrusion, requiring a material deposition as homogeneous as possible to avoid collapsing the structures.

#### **Material properties**

The final clay mix is composed of 90% clay and sand (in equal proportions) + 10% additive (that allows the mix to be more fluid and smoother for robotic extrusion, but its composition cannot be revealed by the authors). The final composite material mix has 3 times higher tensile strength than industrial hard clay.

#### **Machinic Control:**

The interface with the Kuka robot control is through a CAD program: Kuka prc which is a plug-in for Rhino Grasshopper. The advantage of this software is the possibility to also modify the code and have even more freedom than the simple manipulation of the Grasshopper Kuka PRC capsules. The robotic language was Kuka KRL (Kuka Robotic Language).

The feeding device was achieved with one unique motor pushing on the mix under constant force. The extruder was a piston driver custom-made apparatus with metallic parts fabricated by

the researcher. The deposition apparatus included a hot air fan part of the end effect of the robot. Only the on and off command of such system can be controlled computationally.

The width of the deposition was 11 mm, and height from the pouring layer was set at 3.5 mm. The velocity showed a particularly fast deposition at 15cm per sec.

### Code logics

The logic of the digital writing part of the system was based on modifying the geometry and testing different suitable cantilevered parts. It was concluded that 30 degrees from the vertical was on average the maximum geometry allowance of the system in place. The robotic data-flow did not include a responsive element.

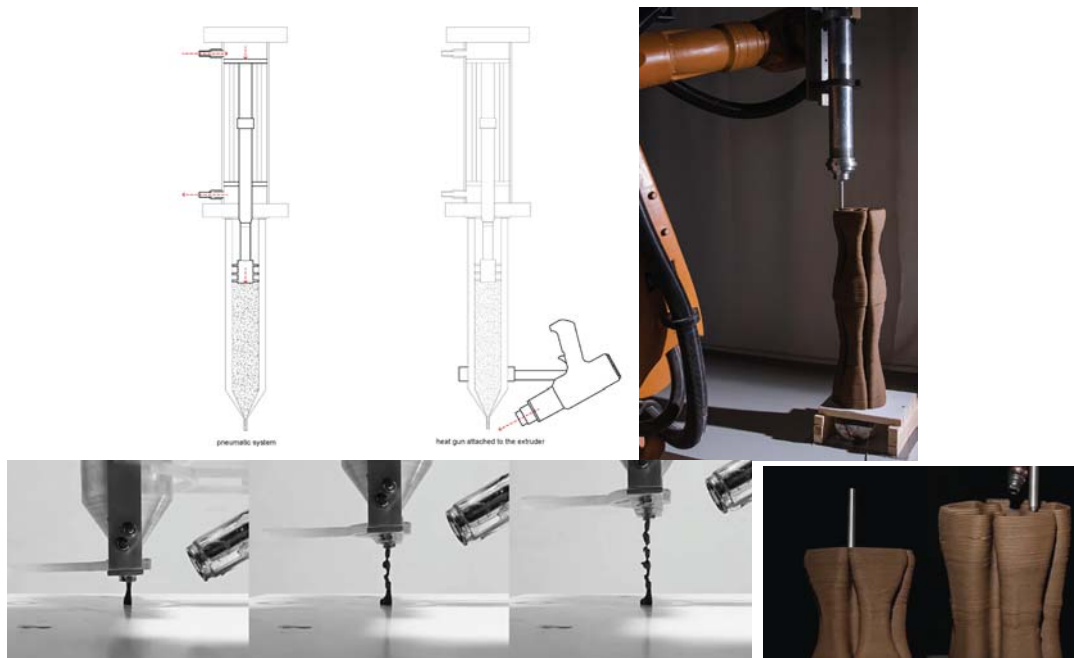

Figure 3. Deposition apparatus and process for Pylos. Project of the Open Thesis Fabrication (OTF)6 months program of Iaac (Institute of Advanced Architecture of Catalunya). Source: Sofoklis Giannakopoulos

## Potentials and limitations of paste matter in robotic fabrication

The results of the proposed 3d printing strategies for mud monolithic shells confirmed the importance of establishing a correct link between the critical aspects (and their transformation during the fabrication) for its successful implementation: matter properties, machine control, and code logics. Many of the errors and failed tests required for any innovative method research has led to consider particularly the data flow between the main elements of the fabrication: 1) the matter properties; 2) the code structure; and 3) the control of the digital tools.

The data flow between these three elements has not been in real time so far, which proves to be an evident limitation for the evolution of this method, still mostly unexplored and not fully understood yet, in terms of the potential it could bring to construction optimization at large scale. Iterative actions could emerge, such as the 3d scanning of the form in progress, with the subsequent



recalibration of the robotic trajectories to correct significant distortions present while the paste mixture is poured, which could potentially compromise the integrity of the constructed form.

During these initial experiments with paste materials, the resulting structures were limited by the size of the robot, the mix weight that could be carried, and the refilling capacity of the feeding tank.

Another consideration is the freedom of geometries that the technique allows, which is linked to the robotic trajectories performed by Kuka robots and controlled by Kuka PRC and set by default. Only the trajectory of the end tool is the variable, while all the 5 other articulations just rotate to allow the overall trajectory of the end point of the tool (in this case the nozzle hole). However, sometimes some trajectories don't allow normal rotations of the 5 other articulations to happen when one member of the robot will collide into each other. Each of the 6-axis in the robot need to be coordinated while rotating and certain trajectories that are drawn in the Rhino model cannot be achieved in reality.

*Mataerial* brings different aspects to consider for future exploration of scale in robotic 3d printing. Apart from being a remarkable experiment based on the freedom of form without any formwork, it provides the evidence that 3d printing at large scale doesn't need to be in all cases done by additive manufacturing layer by layer, but can defy gravity. It also brings the idea of simultaneous actions performed by the same robot while the structure is being fabricated. Here the robot extrudes the plastic mix while at the same time the material is being dried, which allows to print in the air.

An important fact is related to the invisible properties of the paste mix, such as water and air structure, do have a significant incidence on the material application, and therefore some measures must be followed. Firstly, constant stirring is recommended while the structure is being fabricated to avoid paste mix drying or changing consistency. Secondly, the velocity and width of deposition must be checked while the 3d printing is in progress. Finally, drying time must ensure the continuity of the pour, as it directly affects the structural integrity of the form.

The fact that the robot must carry the mixture narrows down the scope of possible experiments to large robotic arms or to regular manual refilling of the tank. However, the naturally resulting forms coming from the technique are skeletons rather than bulky wall structures. For this reason, a possible evolution of this technique that hasn't been significantly exploited so far would be to combine this technique with other 3d robotic fabrication methods to produce robotically informed formwork. A possible hybrid technology involving *Mataerial* as a lost formwork mixed with the robotically sprayed mud shells could lead to innovative sustainable methods, decreasing the "toxic" substances to the initial skeleton formwork, and could allow further evolution of the methods. This combination would avoid the laborious task of setting up the initial "surface" formwork by using a dense version of the 3d printed pipelines of *Mataerial*.

On the contrary, the Pylos project has led to many more clay based robotic 3d printing techniques layer by layer on a flat surface. The Open Thesis Fabrication program of Iaac 2016 has allowed the fabrication of a highly diverse in terms of geometry wall printed by the kuka robot in different blocks of 30 cm side at IAAC OTF 2016. Another interesting related technology that emerged in the years after Pylos was published are the experiments by Rael Fratelli in San Francisco where variation during the continuous robotic deposition of the material and tested and turned into a strong identity in the resulting structures. The limitations of Pylos was related to the size of the robot being always dramatically larger than the resulting structure, limiting this technology so far to further physical probes and to produce smaller scale constructions. It also proved to be manually intensive because it requires refilling the tanks of clay mix regularly.

The spray technique of case study 2 where the initial formwork that was meant to be quick and inexpensive proves to be relatively laborious, hence bringing the air extrusion of case study 1 as an initial or lost formwork for robotically sprayed earthen shells could improve the technique.

A common point between the 3 case studies included in this paper are the different tests of matter mix that are necessary before reaching a compatible synergy with the digital tools controlled





by computer, in terms of controlling certain parameters such as velocity, pressure of extrusion amongst many other parameters. The 3 families of experiments confirmed that the initial mixture is rarely correct and must undergo several tests before finding the right mix, and that organic and non-organic stabilizers are required to be able to use digital fabrication with robotic extrusion or robotic spraying.

The 3 case studies also highlight the fact that complementary actions to avoid phenomenon such as air bubbles in the mix or non-homogeneous matter deposition such vibrating, shaking, rotating the mixes during the fabrication process wasn't implemented yet in many digital fabrication examples.

This paper has exposed that the viability of the 3d printing technique for paste matter is based on formulating a suitable method that considers the correct formulation of material properties, on controlling the evolutive consistency of the mixes during fabrication, develops a proper interface with the robotic control, and works within the code logics. Further developments should expand issues of prototyping at 1:1 scale, implementing real time readjustments of the deposition, exploring non-standard forms, performing structural testing, and testing potential applications.

## Acknowledgements

Our gratitude to Alexandre Dubor, for his contribution of the technical data in the examples shown.

## References

- Ceccanti, F, E Dini, X De, Kestelier Foster+partners, and V Colla. "3d printing technology for a moon outpost exploiting lunar soil." 61st. International Astronautical Congress, Prague, CZ. 2010.
- Dubor, Alexandre, Guillem Camprodom, Gabriel Bello Diaz, Dagmar Reinhardt, Rob Saunders, Kate Dunn, Marjo Niemelä, et al. Sensors and Workflow Evolutions: Developing a Framework for Instant Robotic Toolpath Revision. In *Robotic Fabrication in Architecture, Art and Design 2016*, 410–25. Cham: Springer International Publishing, 2016. doi:10.1007/978-3-319-26378-6\_33.
- Gedeon, Gilbert. P.E., *Introduction to Shotcrete Applications*, 31 January 1993.
- laac, Joris Laarmanlab, *A radically new 3d printing method: Mataerial*, 2014, Available From: <http://www.mataerial.com/> (Accessed Apr, 30, 2017).
- IAC-10-D3.3.5. 3d printing technology for a moon outpost exploiting lunar soil.
- Oxman, Neri et al, "Form Follows Flow: A Material-driven Computational Workflow For Digital Fabrication of Large-Scale Hierarchically Structured Objects I", in *Computational Ecologies: Design in the Anthropocene*, Acadia, 2015.





## Material Dynamics

### Shape Memory Materials in Dynamic Skins

Vera Parlac<sup>1</sup>

<sup>1</sup>University of Calgary, Canada

<sup>1</sup>vera.parlac@ucalgary.ca

**Abstract.** This paper focuses on material-based actuation. It looks into concepts of using smart material technologies to construct material assemblies capable of adjusting to their constantly changing surroundings and environmental conditions. The paper examines several distinct approaches to using shape memory alloy (SMA) in kinetic architectural systems and discusses the possibilities that SMA affords in developing adaptive material systems. The presented work is focused on the application of SMA wire as a non-mechanical actuator and examines how its capacity to change its length and shape can be employed to change the shape and structural and material behaviour of the entire kinetic material system. While the paper focuses on the application of SMA, other forms of material actuation, such as using shape memory polymers, bimetals, and active material printing techniques (4D printing), are also discussed.

**Keywords.** *Smart Materials; Shape Memory Alloy; Material Actuation; Dynamic Architectural Assemblies; Adaptive Architecture.*

## Dynamic Material System as Architectural Assembly

Material systems in nature generate movement and force through the interaction of materials, structures, energy sources and sensors (Jeronimidis 2004). Furthermore, material systems in nature don't distinguish between structural and functional materials. Instead, information about functional and structural needs of an organism travels through integrated material layers and informs material distribution. Naturally constructed material systems have a hierarchical structure on many levels that span several orders of magnitude (Speck and Rowe 2006). Functional properties of these materials can vary and change from one structural hierarchical level to the next, producing variability that can adjust to and accommodate changes in the external and internal environment. Manmade material systems, on the other hand, distinguish between functional and structural aspects of the material. They are constructed, assembled, and designed to respond to a specific design and performance criteria by separating functional and structural aspects of the system.

Technology transfers from fields such as material science, biomimetics, autonomous robotics, interface design and computation are not only influencing the range of the materials used in architecture but the very scale at which they are deployed. Smart materials, for example, may present an interesting opportunity to augment the capabilities of architectural assemblies. Traditionally, architectural components are assembled using several different material layers and every one of them has a particular role and specific material properties. Smart materials, on the other hand, are not artefacts; they are technologies of motion, energy, and exchange. With their capacity for dynamic feedback and energy exchange these materials have a potential to permeate architectural spaces and structures with some of the properties of living organisms. Integrating them into an architectural assembly presents a challenge as well as an opportunity.

This paper reviews several experimental projects that integrate SMA into building skins or dynamic constructs. All of these projects draw on SMA's capacity to change its length when heated;



they derive their dynamics from the force exerted during the shape/length change of SMA. The paper also discusses materials such as shape memory polymers, bimetal and 4D printing techniques to expand the discussion of active matter and material based dynamics.

## Material Actuation

Like many other property changing smart materials, SMA can react to temperature changes in its environment with a significant material response at the molecular level. This is possible due to a phase change of its internal structure. The high-temperature phase (austenite) and the low temperature phase (martensite) define the change of its crystalline structure. This enables SMA to recover its initial shape after deformation through a reversible thermo-elastic phase transformation. In other words, shape memory alloys are functional materials that have an ability to change their shape without permanent deformation and can 'remember' their original geometry.

There are several types of SMAs. The most common are based on a combination of nickel and titanium (Ni-Ti) with roughly 55 to 56 per cent nickel and 44 to 45 per cent titanium. Changing this ratio changes the transition temperature. We can, therefore, have SMA that contracts at the body temperature or at much higher temperatures. The change from martensite to austenite phase causes a stress within the material that results in a 4 to 5 per cent wire contraction i.e. motion [1]. This motion is utilized in various ways in the projects discussed in this paper.

SMA is usually used as an actuator in robotics and aircraft hydraulic systems and in microcircuit breakers, temperature controls and electronic locks. It is also used in medicine as reinforcement for arteries and veins (stents) or in dental braces. Its use in architecture is relatively new. For the past ten years architects have been experimenting with SMA and its application in dynamic structures and surfaces. In the examples discussed here, the SMA is most often used as a linear actuator. The contraction of the wire activates a lever or a system of pulleys that in turn can animate the surface or construct. One of the best examples of this can be found in the work of Philip Beesley and his Hylosoic Ground project. SMA can also be embedded in the surface. In this situation, the force of the activated wire has a capacity to change the topography of the surface. David Benjamin and Soo-in Yang used this in their Living Glass project to open the slots cut into the silicone surface (creating surface "gills"). The force produced by the action of the SMA could (1) act indirectly by producing motion in another connected component that could then move a larger construct (2) or activate the surface directly by producing a tension within the material system. Shape memory alloy wire can also be trained to return to a specific shape after deformation. The 'trained' wire can be embedded into a surface or used to cause a specific change in the construct. This can be seen in the SKiN and Lattice projects by the author, described later in this paper.

When discussing material actuation it is important to mention that electro active polymers, photochemical responsive polymers, or bimetal are also capable of dimensional change that results in surface deformations and, as a consequence, in dynamic surfaces. Electro active polymers are laminated polymers with conductive inks that expand when electrically stimulated. This expansion causes surface deformation. Photochemical responsive polymers change their shape in response to light exposure. The surface deformation can be choreographed by placing light responsive and non-responsive layers in a pattern that would facilitate desired movements. Bimetals operate through dimensional change of two attached metals. As they are heated they expand at different rates causing the surface to curl. All of these materials can be utilized to design dynamic architectural surfaces that operate actively or passively within an architectural assembly. Another promising direction is a technique of multimaterial 3D printing also called 4D printing, where the pattern of printing allows for control and programmability of physical material transformations [2] [3].

## Transformative Effects of Dynamic Surfaces

The Air Flow(er) project by Andrew Payne is a thermally active ventilation device that uses shape memory alloy as a sensor, processor and actuator. The device is imagined as a component of a double-skin façade system and can be integrated to enable a thermal exchange between the perimeter zone and outside. The active component in the Air Flow(er) device is a custom manufactured SMA wire that opens the device when temperature rises thus enabling the air flow through the aperture. After the heat is removed, the wires begin to cool off and the elastic cords pull each panel back into its closed position. In the Air Flow(er) two SMA wires cross over the module opening. When activated the mechanical force generated as the wires shorten rotates the two opposite panels over the pivot points to open them. The system utilizes a force of the elastic cords to pull the panels back in place as the wire cools (Fig. 1). According to Andrew Payne, because of SMA's sensitivity to temperature, Air Flow(er) can provide automatic response during the summer to the rising temperature in the cavity between the inner and outer skin. The hot air could be vented out of the building through the Air Flow(er) mitigating solar gain and decreasing the cooling load on the building's mechanical equipment. In the winter, absorbed radiation can be kept within the cavity of a double-skin facade with Air Flow(er) acting to seal the cavity and using the absorbed radiation to minimize the façade heat loss [4].

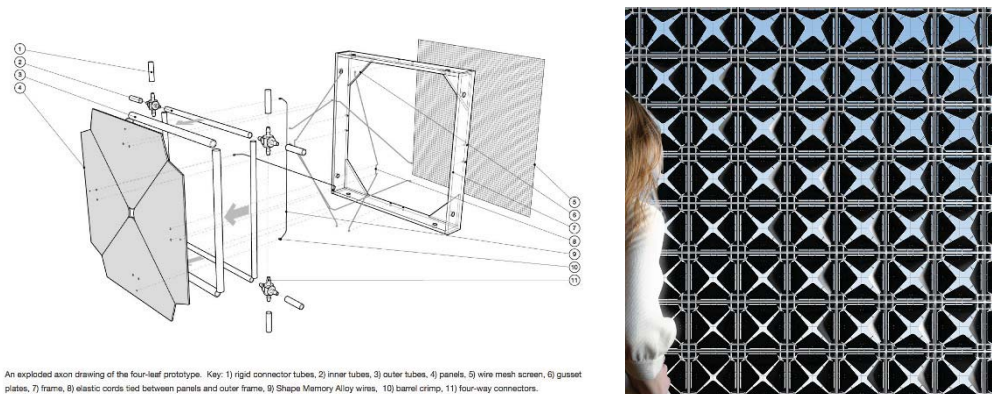
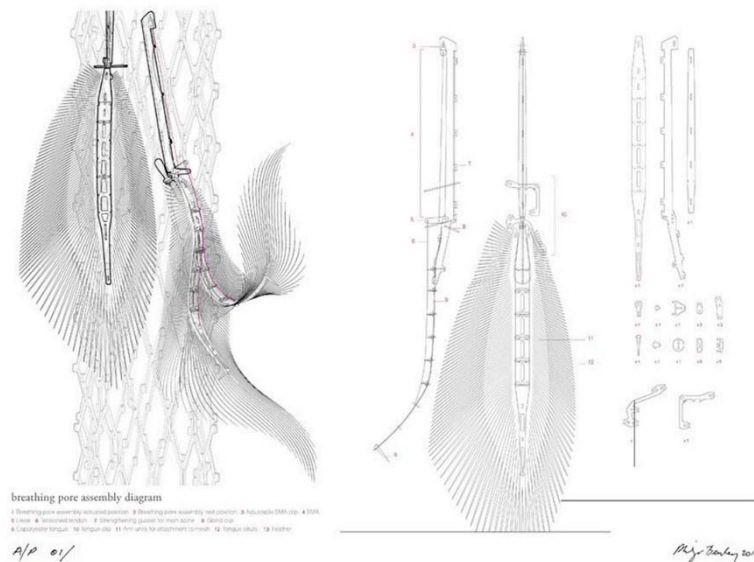

*Figure 1. An exploded diagram of the four-leaf prototype assembly. Photograph of the possible module layout. Diagram and photo courtesy of Andrew Payne.*

This simple materially actuated 'mechanism' is energy independent and operates silently according to the environmental heat it absorbs. It responds to the heat by gently moving panels to allow airflow from the glass cavity. If we imagine an accumulated effect of these panels across a large glass wall – where glass cavities are of different sizes and therefore heating at different time intervals and where modules are strategically positioned to form a changing pattern across the large wall surfaces – the system could, in addition to its environmental contribution, generate dynamically changing material effects across the entire building façade.

This power of a silent dynamic environment afforded by SMA is best experienced in Philip Beesley's Hylozoic Ground Project. In this project a simple dimensional contraction of SMA wire is amplified and proliferated to create a rich and alluring environment that invites exploration and experiential involvement. Most of the dynamic elements in this project use a lever or a system of pulleys to amplify the effect of the SMA wire contraction. The environment includes several kinds of actuating elements: breathing pores, sensor lashes, filters, crickets and swallowing all of them actuated by SMA wires (Elsworthy 2010). The length of the SMA wire plays an important role in the

amplitude of movement. The breathing pores and lashes are driven by ten-inch long Flexinol wire that is only 300 microns in diameter. The contraction of this long wire, amplified by mechanical leverage, translates into a curling motion of the mylar frond. Filters and crickets use shorter lengths of wire in series to provide more subtle kinetic responses. The wire diameter is also important since the weight the SMA wire can lift depends on its diameter. For example, an SMA “muscle” wire with a 0.004” diameter can pull 150 grams per one foot of wire while a 0.012” thick wire can pull 1,250 grams per foot of wire (Elsworthy, 2010). Figure 2 shows a breathing pore assembly diagram where the SMA wire (4) and a tensioned tendon (6), shown in colour, act in unison to curl the mylar frond. (Position change of the mechanical leverage hand is also visible in the axonometric part of the diagram.)



**Figure 2. Hylozoic Ground project breathing pore assembly diagram. Drawing made by Eric Bury and Philip Beesley, courtesy of Philip Beesley.**

In this project SMA wire is used mostly as an actuator; it is not used as a sensor, processor and actuator as in the Air Flow(er) project. Even though the use of SMA is a focus of this paper it is important to mention that other means of actuation are used in the *Hylozoic Ground* project, such as small direct-current motors, SMA powered pneumatic valves, and custom air muscles (Gorbet, 2010). The network of analog and capacitance-based sensors in communication with Arduino processors facilitate the response of the environment to the occupants. The complexity of this interactive environment lies in the orchestration and coordination of many dynamic regions. Over the years of development the *Hylozoic Ground* evolved into an immersive architectural environment “that behaves like a highly mobile crowd of interlinked individuals acting in chorus” (Gorbet, 2010). The *Hylozoic Ground* project hints at what future responsive environments could become. Its performance and contribution are in the exploration of the responsiveness and interaction, creating different experiences that proliferate as one moves through the environment. The environment touches or blows air at the visitor, with its silent, animal like motion triggered by the presence of people and produced by the subtle work of SMA.

The Living Glass project by David Benjamin and Soo-in Yang is another project that questions the assumed inertness of architectural elements and assemblies. The main premise of the project

is that an architectural element should respond to the varying conditions in its environment. To do so, the element would have to collect the information from the environment, process that information and trigger an appropriate response of the surface. The resulting Living Glass surface is thin, transparent and light. It responds to carbon dioxide levels and opens to let in the fresh air. The surface has no motors or mechanical parts. The movement that opens and closes the surface is contained within the surface itself and is triggered by the embedded SMA wire. The rigorous studies of the relationship between the embedded wire and the surface cuts were conducted by Benjamin and Yang, who experimented with the variables of thickness, topography, length of surface cuts, shape of the cuts and wire placement in order to determine the most effective relationship between the cuts and the wire (2006). A full-scale prototype features an array of gills linked to an array of sensors. Activation of the strategically embedded SMA wires opens and closes the gills in response to human presence (Figure 3).

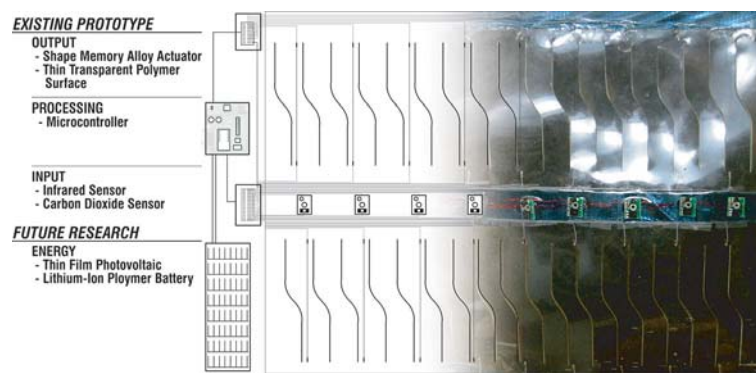

Figure 3. Living Glass project prototype. Courtesy of David Benjamin.

Embedding the shape memory alloy wire into the surface presents another way to actuate that surface. This approach requires experimentation and studies of the surface movement caused by the wire. In the case of Living Glass project, the relationship between the cuts and the wire was carefully studied since deformation of the surface depended on the shortening of the wire, i.e. a straight movement across the surface.

The SMA wire, however, can be trained to conform to a particular shape when heated. When the previously trained wire is embedded into the surface it can alter the surface topography and produce a robust movement. This approach was taken in the SKiN research project developed by the author. The initial phase of the project focused on the studies of movement of the “trained” SMA wire and its effects on the silicone grid and silicone surface in which the wire was embedded. The “V” shaped memory alloy joints were inserted into the silicon tubing (Figure 4). The network joints were “programmed” to open and close and by doing so generate movement of the entire network. This experiment examined the capacity of an SMA wire joint to act as a point source of actuation within the surface. To better understand the gradient of movement the grid was restricted by anchoring joint points to a flat surface in a variety of configurations. The behaviour ranged from expanding grid cells to vertical movements of the grid’s regions. The vertical movement was surprisingly agile and pronounced (Figure 4).



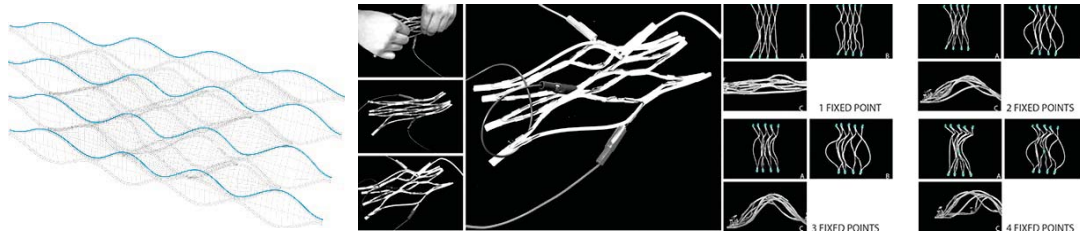

Figure 4. Point actuation using “V” joints and fixed-point test showing the grid deformation.

The second experiment examined the capacity of SMA wire to act as an embedded linear source of actuation. The ‘long’ (45cm) pieces of SMA wire trained/baked into large amplitude (15cm) waves was treaded through the silicone tubing grid. The silicone tubing grid was then integrated into a silicone surface. The fusion of the grid and silicone cells created a structural yet flexible surface that achieved a certain level of material equilibrium; the SMA wire pulled the surface into a particular shape dictated by the large amplitude wave shape while silicone layer pulled the material system back to its original shape, deforming the SMA wire in the process. In this experiment the accumulation of local movements resulted in a complex global movement where each shift of a cell depended on the movement of adjacent cells or regions (Figure 5).

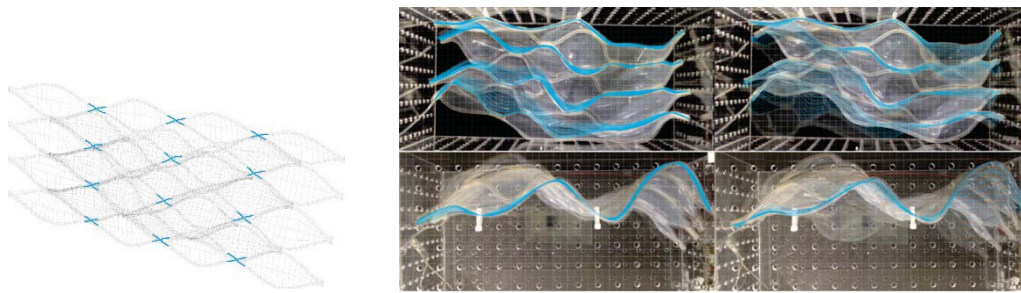
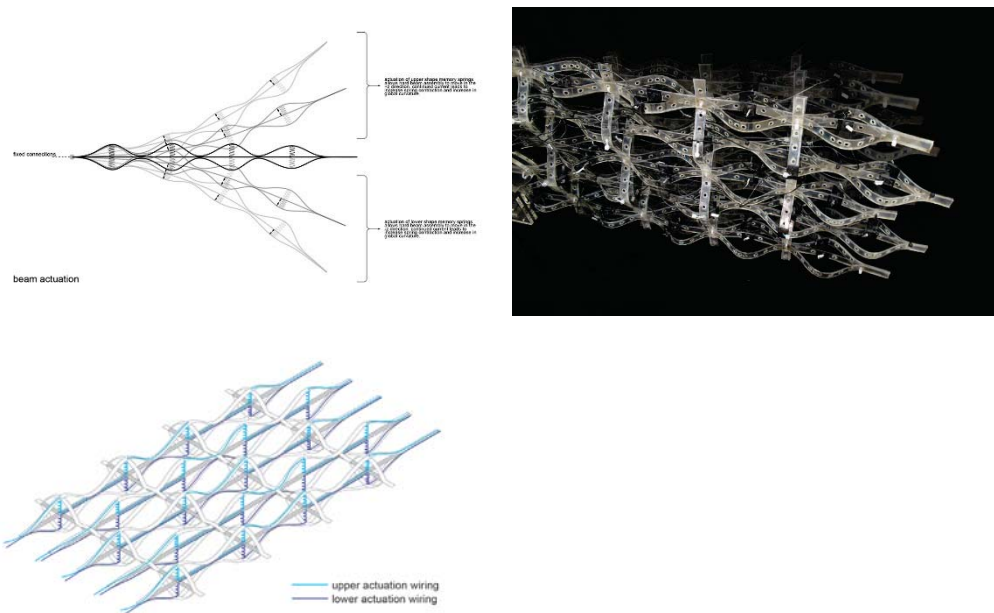

Figure 5  
Using motion tracking to map the movement of the diagrid points.

Both point and linear actuation provide a good strategy to capitalize on aggregation of local movements to produce a global dynamic surface effect. Point actuation facilitated greater variety of movement. Continually reversed joints could produce twisted movement. Linear actuation produced more dramatic movement and reduced the number of connections between the electrical wire and the SMA. Combination of these two strategies could result in a number of patterns that can produce different dynamic surface choreographies.

In contrast to the SKiN project, where movement of the surface was at the centre of exploration, the point of departure for the design of the Lattice project material system was material variability and structural hierarchy found in the naturally constructed materials. This was addressed on two levels. First, an attempt was made to distribute the structural hierarchy across several scales of the material system by using a gridshell lattice and its capacity for deformation as a basic structure of the system. Second, the material variability was explored by adding SMA actuators to the structural lattice to produce deformation (alter the cell geometry of the lattice system) and blur the boundary between functional and structural roles within the system. The gridshell lattice is designed as a uniform grid layout made from elastic members and organized into intersecting three-layered ribs. What is particularly interesting about this configuration is that, because of its connectivity, the cross-sectional local manipulation of the grid “cell” geometry enables a global change of a gridshell form. The gridshell form is altered when the distance between the peaks in the top or bottom and

the middle grid layer is changed. The change in distance is achieved by strategically placing SMA springs between the gridshell layers. Their activation introduces a tension into the middle layer of the lattice. This tension causes bending of the middle layer that results in the movement of the entire lattice structure (Figure 6). Strategic placement of the actuators across the lattice produces accumulated bending effect and can deform the entire surface. SMA is used here to produce the movement of the material system by introducing tension that alters the geometry of the system causing bending and ultimately the movement of the structure. This structural behaviour of the gridshell was instrumental in the development of the kinetic lattice system. Integrating SMA with the lattice enabled variation in the shape and behaviour of the proposed structure. This is best described in the sectional diagram in Figure 6 that shows the sectional change of the “cell” geometry and the consequent change of position.



**Figure 6**  
*Amplitude of bending and cell deformation after SMA spring actuation. Lattice structure physical prototype. Lattice assembly and the actuation logic.*

Even though the application of SMA is a main focus of this paper, several experimental projects using electro active polymers (EAP), photochemical responsive polymers, and bimetals as well as the research using 4d-printing technique are briefly discussed. SMA is usually used as an actuator, i.e. it causes another material to deform by pulling on it. Therefore it has to be integrated into or attached to another material. The EAP, photochemical responsive polymers and bimetals are sheet materials made up of active and non-active layers that deform the surface itself by producing a direct deformation of that surface. The Shapeshift project by Manuel Kretzer and his team shows how EAP can be used to design surface dynamics. The surface is made from EAP components framed in a way to allow flexibility. When activated by electrical current, shape change of each component affects the overall shape of the entire surface. Orientation of the components and the way they are placed within the surface can determine the surface’s overall deformation [5]. The Low Energy Adaptive Façade (LEAF) project by Jin Young Song explores the kinetics of a photochemical responsive polymer sheet by using origami inspired folding pattern. This is a proposal for a shading surface integrated into a building façade. The surface folds or unfolds

reacting to the desired amount of light. The folding is generated by combining light sensitive and non-light sensitive layers into a pattern that facilitates a desired deformation (Song, 2016). The LEAF is energy independent and relies on the light levels in the environment to be activated. The Bloom project by Doris Sung uses bimetallic strips and exploits the difference in rate of expansion of the metals to create a surface activated by to the heat of a direct sunlight [6]. This method of material activation is not new: the thermally induced bending of bimetallic strips has been used in thermostats for decades. What is novel is the shift in scale of application from couple of millimetres to a full size architectural surface.

Another promising trajectory is multimaterial 3D printing where the pattern of active material printing enables the control of physical material transformation. Skylar Tibbits of Self-Assembly Lab has developed a programmed carbon fiber by printing active materials onto flexible carbon fibers and applying heat to activate a transformation. The printing process allows variability as well as a high level of control in shaping the material transformation. According to Tibbits this technology is finding its application in automotive or aerospace industry where dynamic relationship between the shape and performance is desired [2]. Similarly David Correa et al. experiment with printing wood fibers into a custom wood grain structures. This printed material utilizes hygroscopic and anisotropic properties of wood to achieve physical transformations – similar to dimensional change that allows a pinecone to alter its shape and release the seed. Self-transformation of this material is triggered by humidity fluctuations in the environment [3]. Use of material actuation, evident in these examples, eliminates mechanical actuation that requires complex electronics, sensors and actuators. Instead, material actuation exploits inherent or designed properties and behaviors of the material itself.

## Conclusions

This paper describes concepts of using SMA as a smart material technology to construct building assemblies capable of adjusting to constantly changing surroundings and environmental conditions. It also touches upon other shape changing materials and technologies. Integration of the new material technologies into material assemblies offers an opportunity for re-thinking architectural assemblies as adaptive and dynamic material systems. Buildings that respond to change in their environment could have a transformative effect on the built environment and on how we experience and inhabit that environment. As we are incorporating new series of active materials into architectural surfaces their inherent dynamic quality is beginning to undermine the traditional model of material selection in architecture. The model of choosing a material for its properties is being shifted towards choosing a material for its behaviour or even designing a material behaviour to suit a design challenge. We see this in medicine where new materials are made (or grown) to address particular medical challenges.

To imbue material systems with dynamic, changing behavior, their elements need to be actuated, i.e. moved, rotated, expanded, shrunk, twisted, etc. so that the desired performance objectives are met. What differentiates these adaptive examples is not so much what is actuated, but how that actuation is produced. The principal argument is that these new material technologies and their seamless integration into material assemblies could have a transformative effect on the built environment and how we experience and inhabit it.

Throughout the history of architecture, material innovation in architecture has always initiated novel spatial, formal and tectonic expressions. Technological innovation played an essential role in this process, and architect's willingness to experiment with new material technologies has been instrumental in driving their application. Over the past two decades innovations in material sciences and embedded technologies led to the emergence of "sensing" and "active" matter as a new ground for architectural exploration. New materials, such as shape memory alloys and polymers are capable of generating kinetic, visual and other energetic feedbacks. They can induce changes



in kinetic assemblies without mechanical components, through material-based actuation. With their capacity for dynamic feedback and energy exchange, these materials have a potential to imbue architectural spaces and structures with some of the properties of living organisms, leading to the emergence of “living” architecture systems. Integration of these new material technologies in a built environment can result not only in novel tectonic, spatial and formal possibilities but also in dynamic and behavioral expressions of architectural spaces and surfaces that appear to be life-like. This suggests a new kind of potency of matter that is more concerned with change, exchange and effect.

## References

Benjamin, David, and Yang, Soo-in, “Flash Research 1: Living Glass.” in *Life Size*, pp. 33-51, Graduate School of Architecture, Planning and Preservation of Columbia University, New York, 2006.

Elsworthy, William, “Component Design and Actuated Devices An Evolutionary Process”, in Beesley Philip, *Hylozoic Ground: liminal responsive architecture*, pp. 96-111, Riverside Architectural Press, 2010.

Gorbet, Rob, “Revealing the Hylozoic Ground Interaction Layer”, in Beesley Philip, *Hylozoic Ground: liminal responsive architecture*, pp. 112-124, Riverside Architectural Press, 2010.

Jeronimidis, George, “Biodynamincs.” in Hensel, Michael, Menges, Achim and Weinstock, Michael, (eds.), *Emergence: Morphogenetic Design Strategies*, pp. 92-95, Wiley-Academy Press, Chichester, 2004.

Song, Jin, Y., et al., “LEAF (Low Energy Adaptive Façade)”, in Noble, Douglas, Kensek, Karen M., and Das, Shreya, (eds.), *Façade Tectonics World Congress 2016*, vol. 2, pp.144-155, Tectonic Press, Los Angeles, 2016.

Speck, Thomas and Rowe, Nick. P., “How to become a successful climber - mechanical, anatomical, ultrastructural and biochemical variations during ontogeny in plants with different climbing strategies”, in Salmen, Lennart (ed.), *Fifth Plant Biomechanics Conference 2006*, pp. 103-108, STFI-Packforsk AB, Stockholm, 2006.

[1] <http://www.dynalloy.com/pdfs/TCF1140> (accessed April 22, 2017).

[2] <http://www.selfassemblylab.net/ProgrammableMaterials.php>

[3] <https://dspace.mit.edu/handle/1721.1/104845>. (accessed April 20, 2017)

[4] <http://www.liftarchitects.com/#/air-flower/> (accessed April 22, 2017)

[5] <http://materiability.com/shapeshift/> (accessed April 25, 2017)

[6] <http://dosu-arch.com/bloom.html> (accessed April 25, 2017)



## Origami Folded Surfaces:

### kinetic systems behind the folding

Filipa Osório<sup>1</sup>, Sancho Oliveira<sup>2</sup>

<sup>1</sup>ISCTE-IUL, ISTAR-IUL, Portugal <sup>2</sup> ISCTE-IUL, IT-IUL, Portugal

<sup>1</sup>filipa\_osorio@iscte-iul.pt, <sup>2</sup>sancho.oliveira@iscte.pt

**Abstract.** *“Today’s intensification of social and urban change, coupled with the responsibility of issues of sustainability, amplifies the demand for interactive architectural solutions. In the context of architectural need, the attribute of being able to adapt to changing needs is paramount in contemporary society.”* (Fox and Kemp, 2009)

Since the 1960’s that Architecture is progressively more merged with several other fields. Fields like biology, robotics, mechanics, electronics, parametric design, digital fabrication and so many others get to be together through Architecture. It is getting easier and more feasible for the designer to create buildings that are kinetic, interactive and/or responsive in order to communicate with users, enhance the building’s performance in response to changing atmospheric conditions and even transform its own geometry to reconfigure spaces as a functional answer to changing demands.

The use of kinetic buildings, or kinetic elements in a building is becoming a natural response to concrete architecture solutions in order to make buildings “intelligent” and “alive” so they can meet the actual demands of users and use the technological means that are currently available. On this sense this paper focuses specifically on kinetic architectural systems through the use of Rigid Origami Surfaces. Their geometry gives them elastic capacities and is versatile enough to be used in a wide set of systems..

**Keywords.** *Transformable Architecture; Kinetic Systems; Origami Geometry; Operable Roofs.*

## Introduction

If one thinks about deployable/portable buildings as a kind of kinetics it is possible to say that kinetics has been present in Architecture since the nomad man started to construct tents and tipis that could be closed for transportation and opened when a good place for settling presented itself. Also the use of elements like doors, windows, shutters, movable walls, etc., have always been used as kinetic elements in buildings. (Kronenburg, 2003)

Buildings were also thought about, from centuries ago, in a manner that would allow them to be cooler in summer and hooter in winter or to have windows and solar shadings with a configuration that could take the best advantage of the solar trajectory depending on the time of year or day, even if only in a passive way.

Today the architect has at his reach the tools that make possible the design of buildings that can adapt, by transforming themselves, in order to meet the requirements of thermic comfort, insulation and space configuration, among others. Now the architect does not have to design static buildings thinking in the “worst case scenario” which often results in over dimensioned and over equipped buildings wasting resources and money for a situation that might not happen. With the new technologies and kinetic elements buildings may gain the ability to adapt to situations when they actually occur. (Fox and Kemp, 2009)

The present research is placed on this line of thought and focuses on the architectural kinetic systems particularly on the ones relevant to operable/retractable roofs. As a materialization of these

roofs we propose the use of foldable surfaces based on Rigid Origami rules due to their properties of elasticity, self-support and, most importantly, their geometric versatility that makes them able to assume planar, single curvature and double curvature configurations.

## Retractable Roofs

The existing options for retractable roofs for spaces with big span can be characterised in three main categories: Sliding Roofs, Pivoting Roofs, Foldable Roofs.

The most common retractable roofs are the Sliding Roofs. These are made with giant panels that cover part of the building's top and that slide along linear or circular rails.

It is the case of the SkyDome in Rogers Centre, Toronto, Ontario, Canada designed by Rod Robbie and Michael Allen, 1989. This opening roof is composed by two massive steel panels that slide on top of each other on linear rails and a third part of the roof that slides circularly under the other panels allowing the stadium to be almost completely open. (Figures 1 and 2)

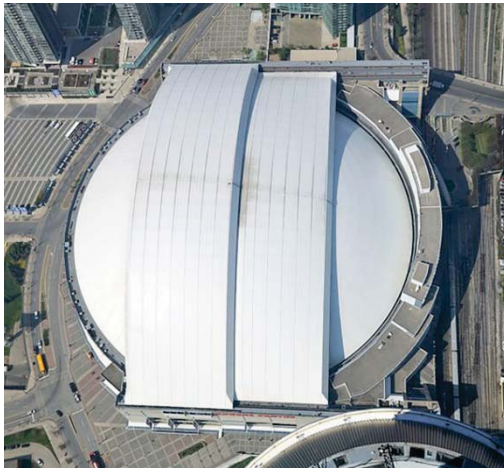

Figure 1. Rogers Centre - Roof closed



Figure 2. Rogers Centre - Roof open

Also the Wembley Stadium in London, designed by Foster and Partners, Populous and the Mott Stadium Consortium, 2007, as a retractable roof. The roof and its structure are made of steel and weight 7,000 tonne that are partially supported by the arch, identity of the stadium.

The central part of the roof is divided in 5 panels that slide linearly on top of each other and onto the static part of the roof. (Figures 3 and 4)



Figure 3. Wembley Stadium - Roof closed



Figure 4. Wembley Stadium - Roof open



The Pivoting Roofs are usually divided radially from the centre of the roof in pieces that rotate around a point or an edge, opening like a camera's diaphragm or a flower.

It is the case of the Qizhong Forest Sports City Arena in Shanghai, designed by Mitsuru Senda and finished in 2005. The roof is made with eight petals, each with 2 tonnes, that rotate about themselves on a point at the edge of the stadium allowing the centre to be open. (Figure 5)

Similarly the Bengt Sjostrom Starlight Theater, 2003, in Rockford, Illinois, designed by Studio Gang O'Donnell has an hexagonal opening area on the roof that opens through the rotation of six triangular modules. (Figure 6)



Figure 5. Qizhong Forest Sports City Arena - Roof open



Figure 6. Bengt Sjostrom Starlight Theater

The category of Foldable Roofs is the one where the Rigid Origami Foldable Surfaces belong, nevertheless the most common are retractable textile like roofs. These ones have very good points on their side. They are much lighter than the examples we have seen before, because it is mainly the structure, that makes the roof fold and unfold, that weights the most. They can collapse into a relatively small space when the roof is open and allow the entrance of light even when the roof is closed.

The BC Place Stadium in Vancouver, British Columbia in Canada had its roof collapsed so, in 2011, it was renovated by Stantec Architecture and Hightex that designed and constructed a textile foldable roof. The fabric retracts to the centre of the roof where lies the scoreboard. (Figures 7 and 8)



Figure 7. BC Place Stadium – roof closed



Figure 8. BC Place Stadium – roof open

The roof of the Wimbledon Centre Court in London, was designed by Populous and Hightex and inserted upon the renovation of 2009. Its structure slides on parallel linear rails that are

hydraulically operated. The steel trusses make the translucent fabric skin fold and unfold. (Figure 9)



Figure 9. Wimbledon Centre Court – View from the inside, roof closed

The existing solutions are very interesting and each one responds to certain problems but all of them leave important issues without solution. The sliding and pivoting roofs are usually very heavy, costly, do not let any light inside the building when they are closed and even when the roof is open the panels occupy a big area. The textile foldable roofs are much lighter, let the light pass and can be compressed into a small space but have no supporting ability nor the capacity to assume a range of geometric configurations.

Although there are no Rigid Origami Foldable Surfaces in use on roofs of constructed buildings we believe that they have the most to offer when compared to the existing solutions, they can be low-weight structures, translucent, assume a wide range of geometric configurations and be collapsed into a very small area.

## Rigid Origami Folded Surfaces

Origami and its geometric possibilities have been used for thousands of years but it was only in the 80's that it began to be deeply studied and only then were defined the 7 axioms that summarize Origami's geometric potential.

These are the Huzita-Hatori Axioms very similar to the Euclidean axioms for constructions with straightedge and compass. The first 6 were defined by Huzita, the seventh was defined by Hatori in 2002, although it had already been formulated by Justin in 1996, these axioms are usually known as Huzita-Hatori or Huzita-Justin. Combining these axioms with operations to divide the paper in  $n$  parts and with the methods to construct any angle it is possible to reach an infinity of possible folding patterns. (Lang, 2010)

The Rigid Origami folded surfaces are of great interest in the fields of architecture and engineering, not only because of the aesthetic possibilities they bring but especially for their geometric, structural and elastic qualities. The possibility of transforming a flat element, without any structural ability, into a self-supporting element through folds in the material opens doors to a multitude of uses.

On a surface folded according to the rules of Rigid Origami it is mandatory that the faces remain flat at all times and that the folds act as hinges between the various faces. It is possible to make the same surface acquire different configurations by applying forces at strategic points which will



oblige to larger or smaller angles between the faces. Therefore, despite the material used is rigid and does not have elastic properties, such a surface has the power to grow, shrink and adapt to several configurations. (Demaine et al, 2011)

These are the reasons that make the folded surfaces particularly suited to meet the requirements of kinetic surfaces that one wants to be light, with self-supporting abilities and able to assume different forms in a kinetic way. Adding to these qualities the Origami Surfaces have the ability to be used as an entire piece that can let a big portion of a building be open or closed, with the impact that brings. With these surfaces the architecture is changing every time because they have several different geometric states that are able to change spaces and the impact they have on users. Each state creates different ambiances through the refraction of light and sound that change as the day goes by or the number of people using the space. Finally, pondering on the matter of scale, these surfaces can achieve more or less resolution depending on the size of the faces, if bigger they act more as solid masses and if smaller the surfaces gain a fluid like expression.

Despite all this kinetic potential Origami has been more commonly used in Architecture in a "frozen" way, i.e., one state of the surface is selected and then statically reproduced with heavy materials. Taking full advantage of the elastic properties of Rigid Origami we can find its use in temporary, mountable and demountable structures, such as the Recover Shelter by Mathew Malone or the Corogami Folding Hut by David Penner. The way these designers use the origami structures allows the structures to be deployed into a flat form so they can be transported or stored, and when they are in use they are self-supported and do not require any additional structural element, however when being used they remain static.

It is possible to find some examples, very few, that use Origami surfaces in kinetic facades or roofs, such as the Al Bahr Towers by AHR Architects or in solar panels and sails used in space satellites. More easily we can find the use of Origami in a kinetic context in academic investigations or in temporary constructions or installations that use it in a kinetic and responsive way. It is the case of Auxetic Origami of Christopher Connock and Amir Shahrokhi from Yale University or the Lotus Dome by Roosegaard Studio. Unfortunately these examples do not use surfaces, they use modules with a small number of faces arranged around a central point, each module functions in synchrony with the ones surrounding it, like they were a surface, but geometrically speaking they are separate units.

## Kinetics

Fox and Kemp (2009) make the distinction of Ways and Means in Kinetic Architecture. For these authors the Ways are the geometric transformations that occur in the kinetic element like folding, sliding, expanding, shrinking and transforming. The Means refer to the mechanics or chemical transformations in the materials that are behind the movement.

Moloney (2011) does not make the same distinction and defends that there are four building blocks for kinetics. For this author there are only three geometric transformations, translation, rotation and scaling and a fourth building block that is movement via material deformation.

We agree with points on both perspectives for what concerns Rigid Origami Foldable Surfaces. There is definitely a distinction between Ways and Means, and the chemical transformations that occur on a material should be placed under the Means category instead of the category for geometric transformations. For the geometric transformations that may occur on a foldable surface the folding one does not have to exist as a category, it is inherent to Origami Surfaces, also expanding and shrinking may be put together as a scaling transformation, which is mandatory on such surfaces. Therefore, for the specific case of Rigid Origami surfaces we consider that the related Ways would be sliding and rotation with a very important distinction, if the surface transformations happen only in one plane or out of the plane assuming single or double curvature.



For the Means we consider the mechanical systems rather than the Material's deformation for we assume there is no material deformation on the surface during the kinetic action. The faces must remain planar and with the same area at all times, the only material deformation is at the creases and is done during the creasing step, so they are irrelevant to the kinetic action.

We define that the most relevant kinetic and structural systems for the opening and closing of Rigid Origami Surfaces are those that can sustain the surface at the same time that they work with the surface's own structural component. These kinetic systems also have to move specific vertices or edges in order to achieve the desired geometries.

Amongst all the "Means" available we believe that the most suited to put Origami Surfaces in motion are Scissor systems, Sliding bars, rails and tensioned cables that work with pulleys. Systems with tensioned cables and pulleys can push and pull specific vertices of the surface. Rails can drive precise vertices in predefined trajectories. Trusses or bars can slide or rotate carrying with them an entire line of vertices or edges. Scissor systems can work linearly as the well-known "Lazy Tongue" or configure curved surfaces that open from the top to the perimeter as the domes invented by Hoberman.

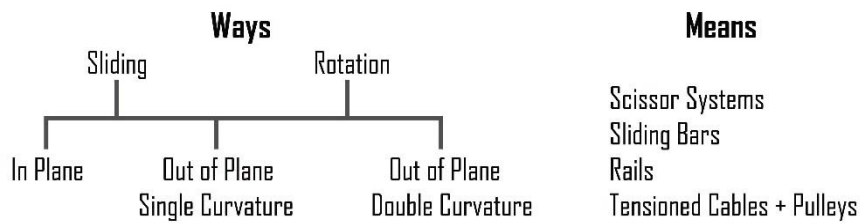

Figure 10. Ways and Means for Rigid Origami Surfaces

Below is presented a table with one Rigid Origami folded surface example of each one of the "Ways" categorized. The table shows the crease pattern and three folding states, from the unfolded to the completely folded state.



		Crease Pattern	Folding State 1	Folding State 2	Folding State 3
In plane	Sliding				
In plane	Rotation				
Out of Plane Single curvature	Sliding				
Out of Plane Single curvature	Rotation				
Out of Plane Double curvature	Sliding				
Out of Plane Double curvature	Rotation				

Figure 11. Examples of Rigid Origami Surfaces for each “Ways”

The kinetic systems can be put in action in an automated way, either with hydraulic, pneumatic or electrical motors that work linearly or rotationally depending on each specific surface and the chosen “Means” for action.

The automation can be a response to diverse stimuli. It can obey a direct command to open, close or assume pre-set configurations or it can dynamically adjust its position in response to other stimulus, such as meteorological, thermic or lighting conditions, proximity of users or objects, or any other, as long as there is a sensor feedback system that can inform the kinetic system in order to put it in motion to achieve a determined geometric configuration.

For all this to occur, and to succeed, the designer must understand the possibilities and limitations of every field present in the definition and construction of a kinetic building or element in a building.

*“The outcome of kinetic design is not a singular form, but a process from which a range of forms manifest over time. This requires designers to consider the design of control system and data input, as well as the design of the physical components.” (Moloney 2011)*





In the case of Rigid Origami Surfaces it is of particular importance the understanding of Origami geometry and the path that the vertices follow from one state to another. Is that path that will give the designer the guidelines to the best kinetic system to use for a particular crease pattern and intended geometric configurations.

## Conclusions

The tools that the designer has today at his reach allow the creation of kinetic buildings, or kinetic elements in a building that can improve the building's performance and adaptability to changing conditions.

We believe that Rigid Origami Surfaces may be a vehicle with great potential to be used in Kinetic buildings due to their specific properties of lightness, elasticity, rigidity and self-supportability. Their rigid, planar faces that rotate around the edges shared with the neighbouring faces allow the same surface to assume different configurations. Such a surface can improve the ability of a building to adapt to different conditions at the same time that it gives the building the capacity of transforming its own geometry creating different ambiances for its users.

Rigid Origami has been utilized in several architectural situations but the use of this kind of geometry as a kinetic surface does not have many examples. It was not yet found a constructed solution that has a Rigid Origami Folded Surface as an operable roof despite their described potential.

In order to create a base for future solutions this paper establishes the Ways and Means for Kinetic Rigid Origami Folded Surfaces, through Fox, Kemp and Moloney's definitions.

## Acknowledgements

This research has a scholarship from Fundação para a Ciência e Tecnologia with reference SFRH/BD/100818/2014.

## References

- Demaine, E.; Demaine, M.; Hart, V.; Price, G.; Tachi, T.; (Non)existence of Pleated Folds: How Paper Folds Between Creases, in *Graphs and Combinatorics*, Volume 27, Issue 3, pp 341-351, Springer Japan, 2011.
- Engel, H.; *Sistemas Estruturais*; Editorial Gustavo Gili, 2001.
- Fox, M.; *Interactive Architecture – Adaptive World*; Princeton Architectural Press, 2016.
- Fox, M.; Kemp, M; *Interactive Architecture*; Princeton Architectural Press, 2009.
- Fox, M: 2003, *Kinetic Architectural Systems Design*, in Kronenburg, R., *Transportable Environments 2*, Spon Press, London, pp. 163-186.
- Kronenburg, R.; *Portable Architecture*, Elsevier/Architectural Press, 2003.
- Lang, R.; *Origami and Geometric Constructions*, langorigami.com, 2010.
- Moloney, J., *Designing Kinetics for Architectural Facades - State change*, Routledge, 2011.
- Schenk, M. and Guest, S., *Origami Folding: A Structural Engineering Approach*, in *Origami5 - Fifth International Meeting of Origami Science, Mathematics, and Education*, CRC Press by Taylor and Francis Group, 2011.

## Co-Habited, Co-Lived, Co-Designed and Co-Created Eco-Systemic Responsiveness in Systemic Approach to Architectural Performance:

### A Case Study on Interaction of Performative Solid Wood Envelope Ray and Algae

Marie Davidová

*Faculty of Art and Architecture, Technical University of Liberec; Faculty of Architecture, Czech Technical University in Prague; Collaborative Collective*

*marie.davidova@tul.cz; marie.davidova@fa.cvut.cz; md@collcoll.cc*

**Abstract.** This paper discusses a wider range of agents in responsive wood performance problematique. This is done through an example of prototyped envelope Ray (see Figure 1) that circulates air in dry warm settings and encloses itself in humid and cold micro-climatic conditions (see Figure 2). The envelope is to be applied on semi-interior or unclimatised spaces of a built environment while securing home to various residents (see Figure 3, Figure 7 and Figure 8). The commonly known factors of wood warping are its ambient air relative humidity and temperature. This research claims that the situation can be more complex and that the performance can be co-habited, co-lived, co-designed and co-created with more abiotic and biotic agents. This involves life preferences and social agendas across the species of the biotic part. This co-creative design process that has over-evolving results leads me to ratification of a new design field: Systemic Approach to Architectural Performance.

**Keywords.** *Systemic Approach to Architectural Performance; Responsive Wood; Co-Design; Performance Oriented Architecture; Time Based Design.*



*Figure 1. Ray 2 Responsive Wood Envelope Prototype a) in Semi-Dry April Weather When the Screen is Partly Open for Boundary Exchange between Exterior and Semi-Interior; b) After April Light Rain When the System is Closed, Not Allowing the Humid and Cold Air to Pass through the Boundary; both after Four Years of Being Exposed to Weather and Biotic Conditions. The prototype got inhabited by Blue Stein Fungi, Algae and Lichen. These, namely the algae, are regulating the moisture content of wood, thus co-causing its warping. Notice also the organisation of algae habitation caused by the material's fibre direction and position within the design that is affected by material performance and form. Thus it is organised through its moisture and the organism's abundance and distribution interaction (photos: Davidová 2017)*

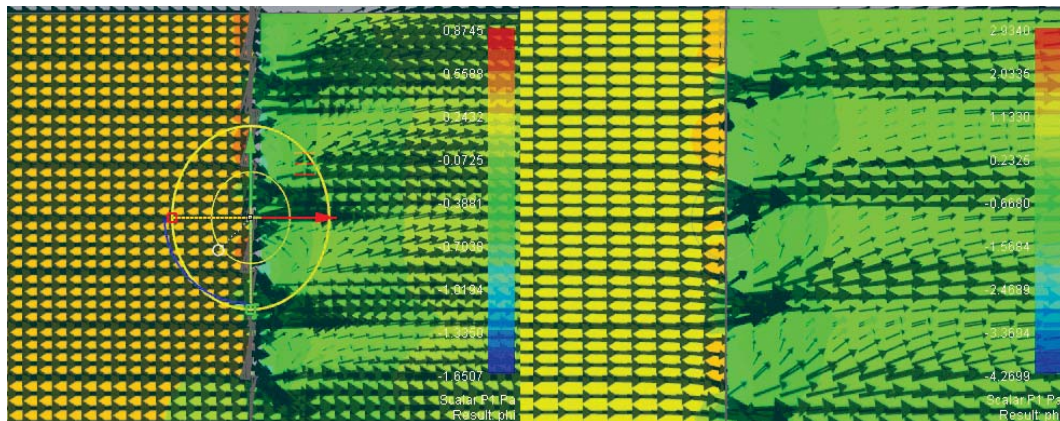

Figure 2. RhinoCFD Fluid Dynamics Simulations Illustrating the Exchange between Exterior and Semi-Interior Spaces through Ray Envelope; a) to the left: situation of dry and hot weather when the screen is open; b) to the right: situation with higher humidity and low temperature (simulation: Davidová 2017)

## Introduction

The present research on responsive<sup>14</sup> solid pine wood focuses on a wider consideration of material-environment<sup>15</sup> interaction. Wood is one of the most important renewable building materials, which has, thanks to its biological basis, specific properties. These include primarily its hygroscopicity, the interaction of the material with relative humidity and temperature for getting into its equilibrium moisture content. This research not only extends the current times of first responsive wood research on laminates and ply-wood founded by Michael Hensel and Achim Menges<sup>16</sup> for the solid wood in tangential section exploration, but it also takes into consideration other species that can interact with it. Wood warps, expands and contracts depending on relative humidity, temperature or other moisture suction of the surrounding environment. The warping of the tangential section generates a so-called 'cup' across the grain thanks to the different fibre density on the left and right side of the sample (Knight 1961). This feature can be used for organizations of individual components into systems that respond to such stimuli for our benefit. Therefore, systems are operated through their primary energy use, without the need for electricity. The Environment Responsive Screen Ray (see Figure 1) proposed by the author is to be applied for semi-interior spaces of human dwellings, airing in hot dry weather and enclosing the space in high relative humidity and low temperature. Such a system enables boundary exchange (Addington & Schodek 2005; Addington 2009) between the outdoor and unclimatised indoor environment (see Figure 2) that is further moderated by climatic heterogeneity of other ambient spaces (Hensel et al. 2009)<sup>17</sup>. It performs in its over-evolving co-design<sup>18</sup> with its surrounding micro-climatic and biotic environment. Unlike the biologic, which discusses synthetic biology for hygromorphic transformation actuation that is to be fully programmed by humans for human-computer interaction (Yao et al. 2015), this exploratory paper discusses co-living, co-design and lived co-

<sup>14</sup> 'responsive suggests mutual reaction and exchange, with adjustments occurring continually on both sides of the use equation.' (Hookway & Perry 2006)

<sup>15</sup> 'Environment is physical and biological surroundings of an organism. The environment covers non-living (abiotic) factors such as temperature, soil, atmosphere and radiation, and also living (biotic) organisms such as plants, microorganisms and animals.' (Oxford University Press 2004)

<sup>16</sup> First current times responsive wood prototype was built by Asif Amir Khan at AA School of Architecture in 2005 under the leadership of Michael Hensel and Achim Menges. This work has been first published in Morpho-Ecologies publication in 2006 (Hensel & Menges 2006).

<sup>17</sup> Please, see the architectural project Pá Vei by Collaborative Collective at Figure 3 as a simple example of such spaces, layered in the onion principle (Davidová 2016a; Davidová et al. 2017; Davidová 2016b).

<sup>18</sup> Co-design and participatory design was explained by Sanders and Stappers, considering only humans. Co-design means co-creation of stakeholders while participation their involvement into the discussion of the design with the possibility of considering their comments (Sanders & Stappers 2008).

creation with other species and abiotic agents within eco-system<sup>19</sup>. This also means that the research is not focusing on synthetic biological fabrication such as Araya et al. (Araya et al. 2012) but on generating ground that is further inhabited and lived by biotic organisms on their own will based on their local specificity.

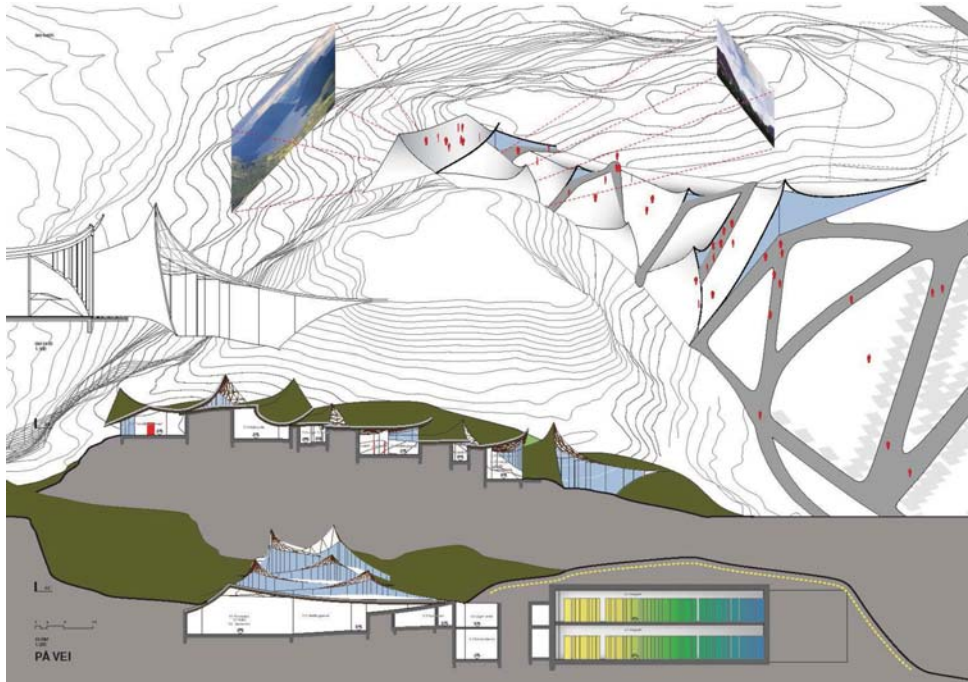

Figure 3. Pá Vei Competition Entry for Vernacular Craft Museum and Gallery Complex by Collaborative Collective exhibits heterogeneity of different climates of the building proposal. These vary from climatized office and archive spaces insulated by ground and green roof, semi-interior to a non-climatized gallery path to be moderated by ambient heat leakage from the offices, and an exterior climate through responsive envelope Ray with the outdoor gallery path to see the exhibits through Ray in pleasant weather. (Collaborative Collective 2011)

## Explorations

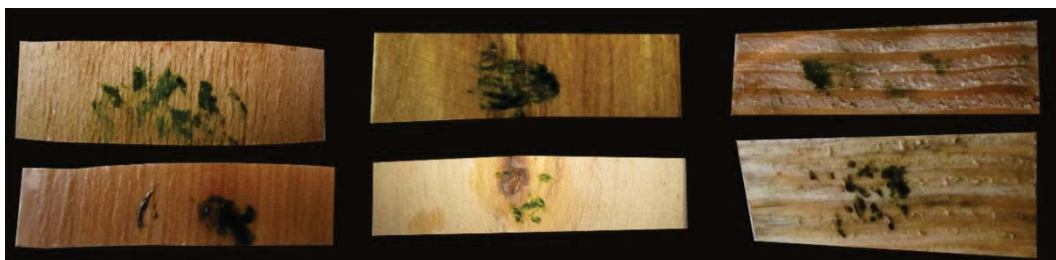

Figure 4: Samples of Artificial Growth of Apatococcus and Klebsormidium (from up to down) on a) Ash; b) False Acacia and c) Pine Wood from - Left to Right, Respectively (photo: Davidová 2013)

<sup>19</sup> Ecosystem was described by Allen and Roberts as an ecological system inside the system that includes the geophysical part (Allen & Roberts 1993).



The original synthetic tests performed on growing algae on wood samples (see Figure 4) were not as successful as exposing the prototypes to a living environment with its local natural inhabitants. The results were obtained by giving a completely free hand to the ambient eco-system. The habitation of other species was speculated but not programmed. Through my speculative observations, algae habitation on wood affects its moisture content approximately by two to four percent in average relative humidity (see Figure 5). In high relative humidity and low temperatures after light rain it can differ by up to ten percent (see Figure 6). Its habitation in a wooden environment responsive screen Ray 2 seems to distribute along the grain at its moistest areas (see Figure 1). This seems to have an effect on the material's warping as its edge part across the grain, where the algae distribution appears, is more sucked out of its moisture. The warping on Ray 2 prototype, with its 30cm height of the panel's triangle, differs by one centimetre in 15°C and 50% relative humidity with higher deformation for the panels with algae. This performance is namely important at the moments with very high moisture, when the algae regulate the warping in the opposite direction. Also, the support of positive warping in arid conditions is very relevant. At the same time, it has been stated by consulting algologists that no local algae will live in the environment under 30% of air relative humidity when exposed to solar radiation. This is very often the case of the placement of prototype Ray, often even being exposed to direct sun. It seems that through the wood's moisture content distribution with its sorption over humid nights and its evaporation over arid summer afternoons, the algae receives sufficient humidity. This concept of performance is common in human settlements from arid regions through so called Oriental wood lattice screens called *mashrabīyas* (Fathy 1986) and is applicable to diverse species. Thus, the algae co-designs and co-creates the human pre-concept and speculation of prototype's environmental interaction as well as its outlook through its co-living and co-habitation.

While Carole Collet discusses co-design with fungus when the organism creates a design pattern and the design process is ended by humans by baking the material thus killing the fungus<sup>20</sup>, this design-research is a 'non-anthropocentric' (Hensel 2013) ever-evolving eco-systemic responsive 'Time Based Design' (Sevaldson 2004; Sevaldson 2017).

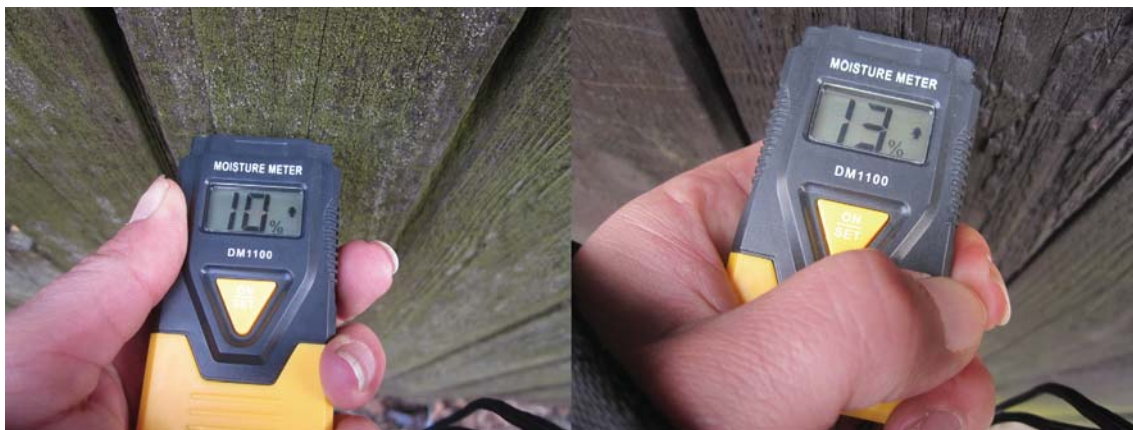

Figure 5: Initial speculation proof on fence with and without Algae Measured with Moisture Meter in Nové Město nad Metují (photo: Davidová 2013)

<sup>20</sup> Carole Collet's public lecture at the Academy of Art, Architecture and Design in Prague 28.11. 2016



*Figure 5. Moisture Content of Panels of Prototype Ray 2 with and without Algae in 8°C and 66% Relative Humidity after light April Rain (photo: Davidová 2017)*

This means that this work does not have the ambition to be fully pre-programmed. The non-living biological material of pine wood attracts the habitation of living non-decaying species whose habitation distributes according to weather-material morphology interaction. The more solar radiation, air humidity and CO<sub>2</sub> are absorbed and also released by these organisms, the more they distribute. This also generates an increase in their abundance. The decaying species are not attracted to pine wood for its highly acidic composition with high amounts of resin. However, the prototype Ray 3 went through salt water soaking of the material. This process removes sugar and amylose from it, thus it does not attract decaying organisms that subsist from these nutrients. This prototype is quite new and is in waiting to be inhabited by biotic agents. Until now, it has mainly performed on its abiotic basis. Therefore, these screens develop over time, not only serving for human settlements.

## Visions of Application

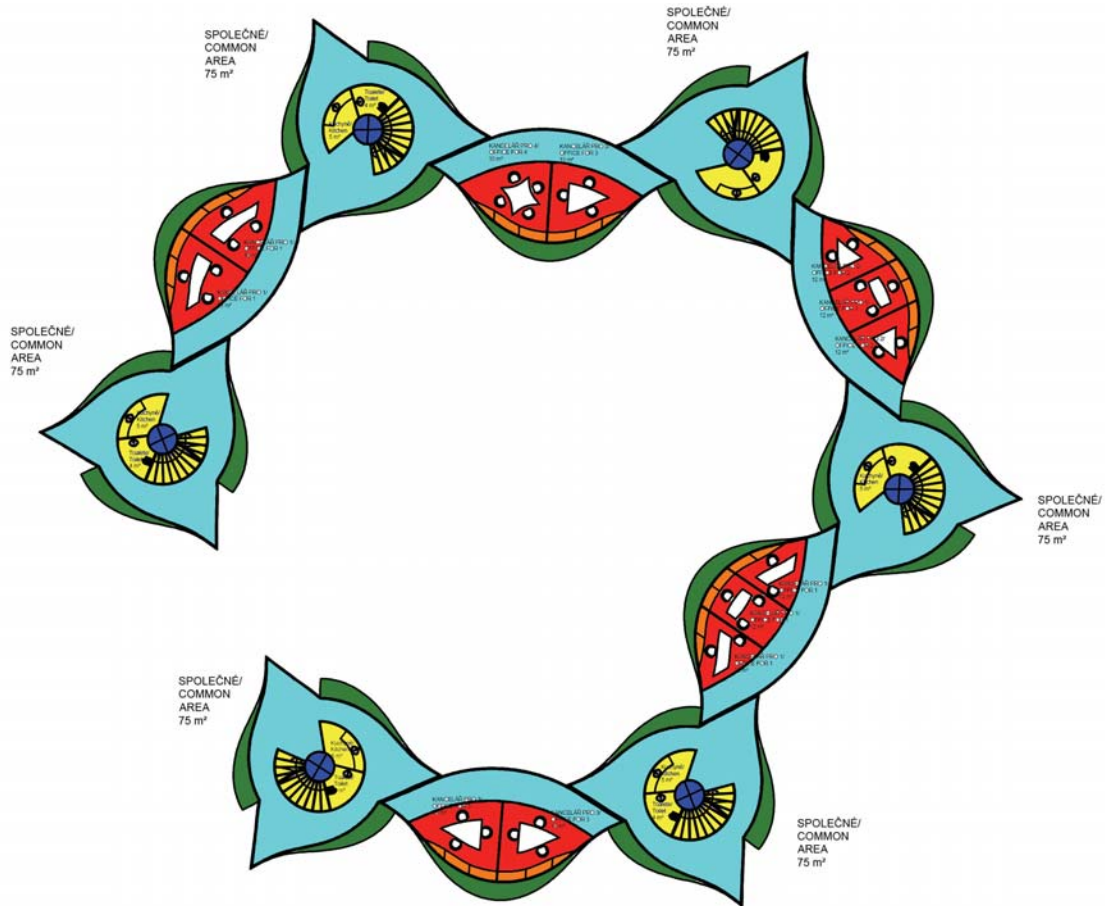
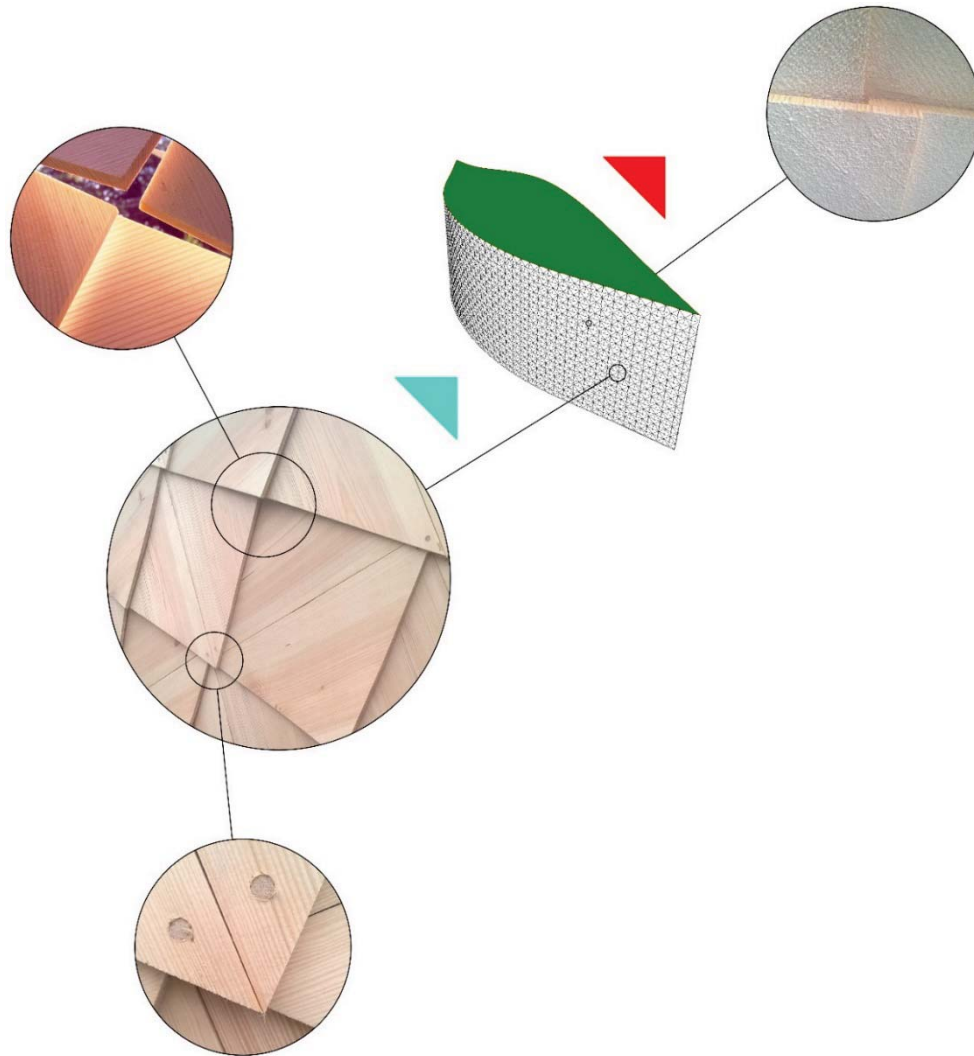

Figure 6: Example of Bio-Climatic Layers of Certain Part of Cells Composition within Small Urbanism in Responsive Transformer Competition Entry for Administration Complex of the Forests of the Czech Republic. The layers in the cells show green surface roofing, tempering storage space, climatised office space and blue semi-interior space, moderated by Ray envelope. The joints are equipped with natural ventilation system from the underground layers of a water reservoir and tempered unfrequently used rooms (Davidová et al. 2017). (Collaborative Collective 2016)



**Figure 7: One Cell within Responsive Transformer Competition Entry Showing the Placement of Ray Envelope and Green surface of Local Species that Produce Edible Goods for Other Species (Collaborative Collective 2016)**

The Ray envelope is to be applied within larger complexity of *bio-climatic layers* (Davidová & Uygan 2017) of a built environment. This concept employs biotic and abiotic agents within heterogeneous environments serving for co-habitation and co-living interaction. The transdisciplinary competition entry by Collaborative Collective /architects (Collaborative Collective 2012; Collaborative Collective 2016), Experis DSKM /structural and mechanical engineers (Experis DSKM 2012; Experis DSKM 2016) and CoolLAND /landscape ecologists (CoolLAND 2016a; CoolLAND 2016b): Responsive Transformer introduced such layers to today's architectural practices (see Figure 7 and Figure 8). This involved the concept of heterogeneous micro-climates, distributing from an underground water reservoir, through large gradients of layers with semi-interior space being penetrable for biotic and abiotic agents through envelope Ray. Extending to its exterior while being inhabited by edible plants and adjacent animals and providing an edible landscape for a variety of species, including humans and social co-designing interaction for the overall eco-system (Davidová et al. 2017). One more layer of algae, being a layer as well as habitant and designer,



can serve as a climatic and pollution moderator within the system, generating a liveable environment for other species.

## Discussion and Conclusions

Overall, such an environment also generates rich human personal and social situations for co-living and another co-creation through its psychological and climate comfort, and understanding of one's belonging to biosphere<sup>21</sup>. Such non-anthropocentric, process based co-design is always beneficial to all, including humans (Davidová 2016b). This can be observed in recent history that through human centrism, focused on short term results, a substantial part of our living environment was destroyed, which leads us to discuss this current crisis. To co-live and co-habitate with other species and the entire eco-system while co-generating our living environment introduces a new vision to co-creation of architectural design, when the design also gives life and involves social-systems to support suitable, interactive and edible environment. After all, this also involves fauna-generated CO<sub>2</sub> pollution, produced by human activity and agriculture that can be consumed namely by algae and also by other flora. However, algae's operative living conditions offer more than that. Its moderation of the ambient environment can co-create speculative architectural performance together with the human based design, micro-climate and other factors. This case studied algae specie is a full member and co-habitant of such processes, which involve its distribution and abundance. This means that the algae are reproduced thanks to the design, material and its ambient environmental factors, such as climate and other species. In addition, the specie is purely local specific, being proposed and applied by the present eco-system that takes part in the co-designing game. Thus, these 'performance-oriented design'<sup>22</sup> processes are feedback<sup>23</sup> looping, when the result is unprogrammable and not really predictable. The initial designer's intention here to be claimed is only the speculation of systemic performance. This collective eco-systemic responsive co-design, where the result is an ongoing process, led me to ratification of new design field: **Systemic Approach to Architectural Performance**.

Co-design in a certain sense has been always involved in the architectural design process as architects often have to co-create with their clients. At the moment, architecture slowly opens itself for a bit more extended transdisciplinarity and participation, unfortunately focusing on biomimicry systems rather than on life biological creations themselves. This exploratory paper states that this is not enough. We need to co-design the performance in real time with the overall eco-system and its biotic and abiotic agents. This involves various disciplines, living species and climatic agents.

## References

Addington, M., 2009. Contingent Behaviours. *Architectural Design*, 79(3), pp.12–17. Available at: <http://doi.wiley.com/10.1002/ad.882> [Accessed December 31, 2016].

Addington, M. & Schodek, D.L., 2005. *Smart Materials and Technologies in Architecture* 1st ed., Oxford: Architectural Press - Elsevier. Available at: <https://bintian.files.wordpress.com/2013/01/smart-materials-new-technologies-for-the-architecture-design-professions.pdf> [Accessed December 9, 2016].

---

<sup>21</sup> Biosphere is 'irregularly shaped envelope of the earth's air, water, and land encompassing the heights and depths at which living things exist. The biosphere is a closed and self-regulating system (see ecology), sustained by grand-scale cycles of energy and of materials—in particular, carbon, oxygen, nitrogen, certain minerals, and water. The fundamental recycling processes are photosynthesis, respiration, and the fixing of nitrogen by certain bacteria. Disruption of basic ecological activities in the biosphere can result from pollution.' (Lagasse & Columbia University 2016)

<sup>22</sup> 'Performance-oriented Design is a research area dedicated to the formulation of an inclusive to design design based on the interaction between the different domains of agency that make up the human environment.' (Hensel 2015)

<sup>23</sup> 'The feedback principle: The result of behaviour is always scanned and its successes or failure modifies future behaviour.' (Skytner 2005)



Allen, T.F.H. & Roberts, D.W., 1993. Foreword. In R. E. Ulanowicz, ed. *Ecology, the Ascendent Perspective*. New York: Columbia University Press, pp. xi–xiii.

Araya, S., Zolotovskiy, E. & Gidekel, M., 2012. Living Architecture: Micro performances of bio fabrication. In H. Achten et al., eds. *Digital Physicality - Proceedings of the 30th eCAADe Conference - Volume 2*. Prague: Czech Technical University in Prague, Faculty of Architecture, pp. 437–448. Available at: [http://papers.cumincad.org/data/works/att/ecaade2012\\_243.content.pdf](http://papers.cumincad.org/data/works/att/ecaade2012_243.content.pdf) [Accessed February 12, 2017].

Collaborative Collective, 2012. Collaborative Collective. Available at: <http://www.collaborativecollective.cc/> [Accessed January 1, 2013].

Collaborative Collective, 2016. Coll Coll. Facebook, p.1. Available at: <https://www.facebook.com/collaborativecollective/> [Accessed August 14, 2016].

CooLAND, 2016a. CooLAND. Cesta do krajiny, p.1. Available at: <https://www.facebook.com/cestadokrajiny/> [Accessed August 24, 2016].

CooLAND, 2016b. CooLAND. CooLAND, p.1. Available at: <http://www.cooland.cz/> [Accessed August 24, 2016].

Davidová, M., 2016a. Ray 3: The Performative Envelope. In M. S. Uddin & M. Sahin, eds. *2016 DCA European Conference: Inclusiveness in Design*. Istanbul: Özyeğin University, pp. 519–525. Available at: [https://www.researchgate.net/publication/307934969\\_Ray\\_3\\_The\\_Performative\\_Envelope](https://www.researchgate.net/publication/307934969_Ray_3_The_Performative_Envelope).

Davidová, M., 2016b. Socio-Environmental Relations of Non-Discrete Spaces and Architectures: Systemic Approach to Performative Wood. In P. Jones, ed. *Relating Systems Thinking and Design 2016 Symposium Proceedings*. Toronto: Systemic Design Research Network, pp. 1–17. Available at: <https://drive.google.com/file/d/0B-0w-H8C5IDCWEtScUINaVNrX1E/view>.

Davidová, M. & Uygan, E., 2017. Living in Bio-Climatic Layers: An Investigation of Cappadocian Caves in Relation to Today's Design and Its Futures. In F. Mahbub, S. Uddin, & A. M. Khan, eds. *International Design Conference: DESIGN EVOLUTION [Education and Practice]*. Karachi: Indus Valley School of Art and Architecture, pp. 1–12. Available at: [https://www.researchgate.net/publication/313759290\\_Living\\_in\\_Bio-Climatic\\_Layers\\_An\\_Investigation\\_of\\_Cappadocian\\_Caves\\_in\\_Relation\\_to\\_Today%27s\\_Design\\_and\\_Its\\_Futures](https://www.researchgate.net/publication/313759290_Living_in_Bio-Climatic_Layers_An_Investigation_of_Cappadocian_Caves_in_Relation_to_Today%27s_Design_and_Its_Futures).

Davidová, M., Zatloukal, J. & Zimová, K., 2017. Responsive Transformer: The Bio-Robotic Adaptive Architecture. In F. Mahbub, S. Uddin, & M. A. Khan, eds. *International Design Conference: DESIGN EVOLUTION [Education and Practice]*. Karachi: Indus Valley School of Art and Architecture, pp. 1–8. Available at: [https://www.researchgate.net/publication/313759423\\_Responsive\\_Transformer\\_The\\_Bio-Robotic\\_Adaptive\\_Architecture](https://www.researchgate.net/publication/313759423_Responsive_Transformer_The_Bio-Robotic_Adaptive_Architecture).

Experis DSKM, 2012. Experis DSKM. Experis DSKM. Available at: <http://www.experis-dskm.cz/> [Accessed November 20, 2016].

Experis DSKM, 2016. Experis DSKM. Facebook. Available at: <https://www.facebook.com/Experis.DSKM/> [Accessed November 20, 2016].

Fathy, H., 1986. *Natural Energy and Vernacular Architecture: Principles and Examples with Reference to Hot Arid Climates*. Chicago and London: The University of Chicago Press, Chicago and London: The University of Chicago Press. Available at: <http://archive.unu.edu/unupress/unupbooks/80a01e/80A01E00.htm>.



Hensel, M., 2013. *Performance-Oriented Architecture: Rethinking Architectural Design and the Built Environment* 1st ed., West Sussex: John Wiley & Sons Ltd.

Hensel, M., 2015. *Performance-Oriented Design*. Available at: <http://www.performanceorienteddesign.net/> [Accessed April 3, 2016].

Hensel, M., Hight, C. & Menges, A., 2009. *Space Reader: Heterogenous Space in Architecture* M. Hensel, C. Hight, & A. Menges, eds., London: Wiley.

Hensel, M. & Menges, A., 2006. *Morpho-Ecologies* 1st ed., London: AA Publications.

Hookway, B. & Perry, C., 2006. *Responsive Systems|Appliance Architectures*. *Architectural Design*, 76(5), pp.74–79. Available at: <http://doi.wiley.com/10.1002/ad.326> [Accessed December 31, 2016].

Knight, E., 1961. *The Causes of Warp in Lumber Seasoning*, Oregon.

Lagasse, P. & Columbia University, 2016. *The Columbia Encyclopedia* 6th ed., New York: Columbia University Press.

Oxford University Press, 2004. *World Encyclopedia* 1st ed., Published Online: Philip's. Available at: <http://www.oxfordreference.com/view/10.1093/acref/9780199546091.001.0001/acref-9780199546091> [Accessed January 21, 2017].

Sanders, E.B.-N. & Stappers, P.J., 2008. *Co-creation and the new landscapes of design*. *CoDesign*, 4(1), pp.5–18. Available at: <http://dx.doi.org/10.1080/15710880701875068> [Accessed December 27, 2016].

Sevaldson, B., 2004. *Designing Time: A Laboratory for Time Based Design*. In *Future Ground*. Melbourne: Monash University, pp. 1–13. Available at: <http://www.futureground.monash.edu.au/>. [Accessed December 9, 2016].

Sevaldson, B., 2017. *Systems Oriented Design*, in preparation.

Skyttner, L., 2005. *Basic Ideas of General Systems Theory*. In *General Systems Theory: : Problems, Perspectives, Practice*. Singapore, Hackensack, London: WORLD SCIENTIFIC, pp. 45–101. Available at: [http://www.worldscientific.com/doi/abs/10.1142/9789812384850\\_0002](http://www.worldscientific.com/doi/abs/10.1142/9789812384850_0002) [Accessed December 10, 2016].

Yao, L. et al., 2015. *bioLogic: Natto Cells as Nanoactuators for Shape Changing Interfaces*. In B. Begole & J. Kim, eds. *CHI '15 CHI Conference on Human Factors in Computing Systems*. Seul: ACM, pp. 1–10. Available at: <http://tmg-trackr.media.mit.edu/publishedmedia/Papers/564-bioLogicNattoCellsas/Published/PDF> [Accessed February 11, 2017].



## Fabric Materiality FRP

### Shifting towards structures of bio-inspired properties

Arielle Blonder<sup>1</sup>

<sup>1</sup>*Technion Institute of Technology, Faculty of Architecture and Town Planning, Haifa, Israel.*

<sup>1</sup>*Arielle.blonder@gmail.com*

**Abstract.** Fibre reinforced polymers (FRP) is a family of high performance composite materials combining fibres and polymer matrix, structurally resembling biological materials. While biological design principles could naturally be applied for engineered FRP, these are hardly applicable with standard FRP fabrication processes relying totally on moulds. Searching for alternative design and fabrication processes, the research presents the integration of Fabric Materiality, relying on the textile capacities of the material to enable a bio-inspired approach. Learning from a bird's nest, principles regarding material, structure and construction process were applied to an architectural FRP structure, which demonstrates traits of biological composite materials, suggesting a resilient porous matter-structure.

**Keywords.** *FRP; Composites; Materiality; Fabric; Biomimetics; Nest; Resilience.*

## Introduction

### *Fibre composites and biology*

Fibre composites are synthetic in their composition, but similar in their structure to biological materials, composed of fibre and matrix. Fibre based composite materials have been used by man since antiquity, when wood and straw were coupled with mud, to produce the brick. From the 1950's and until today, advanced fibres such as glass, carbon and aramid, are combined with polymers, to make an extremely strong and lightweight material commonly referred as Composites, or fibre reinforced polymers (FRP) (Fernandez 2005).

Structured by fibres and matrix, fibre composites resemble living materials. Almost all load-bearing biological structural materials, organs and tissues are fibrous composites, comprised of fibres such as cellulose for plants and collagen for mammals (Jeronimidis 2013). Similarly to living materials, FRPs potentially introduce biologically inspired design paradigms; like in nature, a wide range of functional properties can be achieved by the careful design of the two components, varying spatial and hierarchical organisation (Knippers and Speck 2012). In contrast to conventional and uniform mechanically engineered qualities, the composite design approach suggests engineered continuous variation, local deposition of material in accordance with structure and performance. Nevertheless, despite the similarity in their fundamental performance principles, FRP's commonly applied engineering strategies differ greatly from nature's strategies and standard FRP fabrication processes and applications do not relate to biological design principles. Key principles such as self-organisation, variation and differentiation can hardly be obtained through the mould-based standard fabrication processes of FRP, in which complex or varied shapes require the fabrication of multiple complex sculpted forms as moulds. The theoretical connection between technical textiles and biomimetics is well established in the research field (Milwich et al. 2006), but

the integration of biological design principles in FRP still present a call for alternative fabrication processes that are free from limiting moulds and sustain variation.

Attempts for the integration of such design concepts can be found in engineering research oriented towards bio-inspired composites, in theoretical architectural writing oriented towards material systems and in several architectural experimental design researches, mainly conducted by ICD Stuttgart with the ITKE. These focus on the integration of principles of biological composites into the design and fabrication of architectural FRP (Parascho et al. 2015), tackling the material on the fibre level, mainly dealing with direct robotic fibre placement.

### ***Fabric Materiality FRP***

This paper presents Fabric Materiality (FM) as an alternative approach to FRP design and fabrication, which can potentially introduce concepts and properties of biological materials into engineered fibre composites. Fabric materiality is a term coined to represent the totality of qualities, attributes and techniques associated with fabric materials, which potentially interface between disciplines as a basis for transfer of technologies. Associated with FRP in this research, it relies on the fabric qualities of the fibre constituent of the composite, to be embedded in the design and fabrication of architectural structures (Blonder and Grobman 2016). Though architecture and textiles have multiple points of convergence, the world of fibres presents a design paradigm that strongly differs from the mechanical-based architectural one.

Three attributes are defined as the core of FM, through which integration is considered: fabric manipulations, self-organisation and resilience. Fabric manipulation refers to the multitude of parameters that affect the physical properties of the fabric, from the fibre itself to its spatial structuring by weaving, felting, knitting etc. Self-organisation refers to manipulations on a higher level of hierarchy, dealing with the fabric itself and its ability to embrace complex forms, responding to the application low-energy stresses upon it. The resilient properties of fabrics derive from its internal structure, based on a multitude of simple and weak elements that interact and construct a greater whole, granting it with flexibility and ability to recover to an initial or improved state after an event of stress, demonstrating soft stability and robustness.

Fabric materiality suggests a biologically inspired design approach to composites, redefining the fibres' role in the making of the forms. Replacing the restrictive moulds with fibres, it enables local differentiation, inherent optimization, ornamentation and sustainable variation, which are essential to achieve complex structures with bio-inspired properties.

### ***Bio-inspired Fabric Materiality FRP structure***

The integration of FM in FRP design and fabrication is hereby demonstrated through a case study, "The LifeObject" [Figure 9]. Aiming to embed biologically inspired principles through FM, the architectural installation takes a natural structure as a reference model for a biomimetic development process. The bird's nest was chosen as a biological model of a resilient structure, to be analysed and studied through a biomimetic process and implemented as a FRP structure. The analysis of the bird's nest of a Jordan Sparrow served as a basis for the development of a material system and was applied on multiple levels involving material, structure, fabrication and construction process.

In between bio-inspired design and biomimetics, the LifeObject development process consists of the transposition of principles learned from the nest onto a structure of a different form, purpose and material. Not intended for the safekeeping of eggs, the designed structure is not a closed circular shape, nor is it made of collected branches; rather, it is a curvilinear architectural installation of synthetic engineered material. In that respect, and with the general aim to explore a comprehensive alternative approach from design to fabrication, a careful selection of relevant characteristics to be taken from the bird's nest was compulsory. Combining a numeric analysis with

qualitative observations, relative figures were selected (such as relative distribution and angles), and generic principles of structural and construction logics.

The implementation of the principles learned from the nest resulted in a structure that demonstrates biological characteristics. In between a spatial structure and a volumetric porous structural material, the LifeObject can be regarded on different scales. The paper will start with the description of the nest and the information extracted from it for implementation in the structure, with a brief description of the numeric process. The following section will detail the design, fabrication and construction of the LifeObject, described through four characteristics of biological composites: hierarchal structure, low energy synthesis, self-organisation and adaptability.



Figure 8. LifeObject installation; resilient FRP structure by Fabric Materiality

## Learning from a bird's nest

Birds' nests have long been of high interest for biological research, referred to as 'frozen behaviour'. Seen as a diagrammatic representation of the behaviour of a species, nests demonstrate the ways by which species attempt to arrange their natural environment. The great diversity of nests of different species illustrates different behavioural, ecological, and evolutionary principles, with a special focus is put on the different processes of adaptation of the nests to the different environments. (Collias 1986). This study related to the resilient structural properties of the nest, having spatial structural applications in perspective. The information taken from the nest in the biomimetic process to be implemented in the designed structure combined general qualitative characteristics of the nest, with its numerical analysis. The numerical analysis examined its internal structure, and the characteristics related both to its material and the construction behaviour.

### ***Nest characteristics: construction behaviour and material***

Birds' nests demonstrate a huge variety of types, sizes, shapes, techniques and materials. Categorisation relates to eight different nest shapes, combined with eight different sites and ten ways of attachment (Hansell 2000). Though a simple generalisation cannot be done to select a generic nest structure, the one selected for the study is the most widely spread type, a cup-shaped nest. The nest of the Jordan Sparrow (*Passer Moabiticus*), selected for this study [Figure 10a] is located on trees and its attachment is "bottom multiple branched", supported from below by contact with two or more branches, locked in position by virtue of its own weight and the projecting twigs between supporting branches.





Although there is enough similarity between different nests for a collector to recognise the species by the built structure, still little is known about the process by which the bird knows how and what to build, the cognitive complexity required and the degree of repeatability between nest structures (Healy, Walsh, and Hansell 2008). Generally, some architectural variability is evident where nests are fitted to the individual topography of a nest site, while the composition and construction of the nest as a whole is rather invariant and species-typical (Hansell 2000).

The most important construction system amongst birds is by interlocking, including three types: fastening that is in the construction material itself (Velcro), fastening that is created by the builder (pop-rivet and stitches), and entangle by the builder (Hansell 2009). The selected nest is built by entangle, involving no additional materials for gluing or assembly. It has been proven that the beak is not morphologically adapted to the building task, but rather to the task of feeding its youngsters (Hansell 2009); in the absence of a specialized tool for the construction of the nest special care is taken in the choice of materials, to make construction itself more easy and create a strong nest. The twigs selected for the nest have spikes that assist entanglement, and are supple enough for bending with resistance. Carefully selected for their weight in relation to the builder, the twigs display variations within a standard range (Hansell 2000).

### ***Applying nest principles as design requirements***

The nest was chosen as a model for lightweight double-curved structure of resilient properties, to be implemented as a FRP structure. Of special interests were the principles observed in the nest, which stand in contrast to conventional engineering methods or logics of construction and contribute to its resilient behaviour. These were set as design requirement from the LifeObject, serving as guides for its development.

The complex double curved shape is to be obtained from simple linear elements, which are not custom made but acquire their specific curved shape by bending. The elements will be extremely light and easy to transport and manipulate during construction, and therefore the structural logic will rely on multiplicity and redundancy of light and relatively weak materials. The elements will be assembled by entanglement only, relying on the mutual friction between elements and on inherent stoppers (imitating the twigs' spikes). No additional joints or gluing agents will be used, and the surrounding environment (ceiling and floor) will serve as anchors for stabilisation (by pressure only). No scaffolding will be used for construction and structure will be stable at all stages.

The variability between nests will be implemented as a random-based iterative design code, that will assure a different random arrangement of twigs in space that share common traits. In correlation, the construction logic will integrate top-down and bottom-up elements, with intentional partial control over the process.

### ***Numerical analysis of the nest***

To operate an algorithmic analysis on the nest's structure, a digital model was necessary, starting with an x-ray computed tomography (CT). [Figure 10b] Challenged by the dense complex structure of the interlaced twigs, image processing algorithm was developed in a dedicated python script to extract a clean skeleton diagram of branches out of the scan, to isolate the twigs as separate entities and to extract the branch thickness. The raw skeleton of the nest was then coupled with branch thickness data, as textual data for algorithmic analysis; it was visualized through Grasshopper-Rhino as a 3D mesh [Figure 10c].

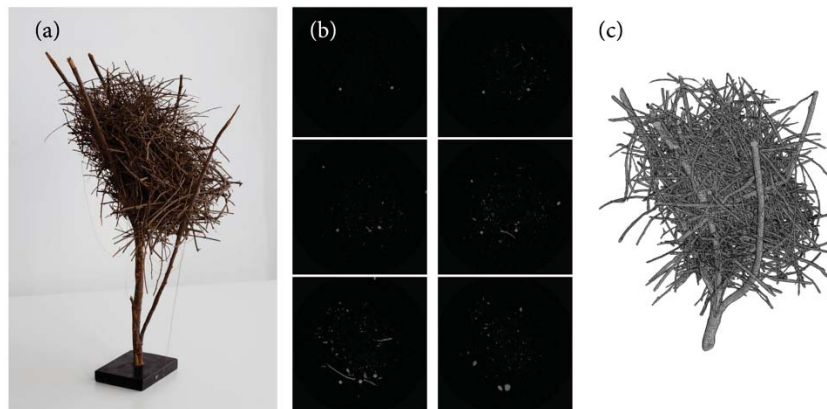

Figure 9. Nest digital reconstruction (a) Jordan Sparrow nest (photo: Amit Ofek) (b) Selection of images of CT scan (c) Reconstructed digital model (process: Lior Aharoni)

Based on the digital reconstruction of the nest, an algorithmic analysis was processed to extract relevant data from the nest structure. As the purpose of the biomimetic process was its implementation in an architectural structure that does not resemble the nest in its form (circular and closed) nor in its performance (egg protection), only non-dimensional and relational parameters were analysed and extracted from the nest. These were: twig length deviation, twig thickness deviation, angle between twig and floor, angle between twig and the thickness of the nest, and density.

The extracted data thereafter informed a design code, written in Grasshopper-Rhinoceros, to randomly populate bounding free-form volumes, subject to the numerical principles of the nest. The implementation of the data was based on the assumption that the nest equated the inner forces to zero by its closed shape, which was obtained in the designed structure using enviroing floor and ceiling as anchors. In an iterative process, the design algorithm populates the bounding volume until it reaches the required density of twigs. Twigs of random length according to the length deviation data are randomly placed, subject to the angle deviation data of the nest; each twig is positioned to intersect neighbouring twigs at a minimum of three different points along it, to assure its interlacing and bending.

## LifeObject

The principles and figures extracted from the study of the nest were applied in the development of a material system, an assembly of extremely light tubular elements, interlaced in a complex spatial organisation. The study informed the fabrication process of the tubular components as well as a parametric design code that populates free-form volumes with the components to form the structure. Applying the code for a specific site, two free-form volumes were positioned in space, and detailed fabrication data was automatically generated for over 1500 tubular elements, comprising the structure. The elements were manufactured by knitting, as continuous sleeves, then impregnated with resin, shaped and hardened in a manual process. The elements were assembled on site, forming a structure by interlacing, without the need for joints or gluing agents.

The developed bio-inspired material system holds properties of biological composite materials; the case study will be detailed and described thematically, through four main biological material characteristics.

### Hierarchical material construction

Biological materials are hierarchically structured as an integral part of their design, making no distinction between material and structure. Since the biological raw material in itself is weak, brittle and soft, its strength and stiffness is achieved by its layered internal architecture. While each level consists of similar molecular components, the differentiated spatial organisation results in a variety of functional properties (Dunlop and Fratzl 2010). A natural material, like wood, would have an array of hierarchies spanning across 15 orders of magnitude. From the size of the nanometric cellulose micro-fibrils ( $10^{-12}$ ), to the wood tissue measured in cm ( $10^3$ ), seven level of hierarchies can be determined: tissue, cell, laminated cell wall, individual wall, cellulose fibres, microfibrils and protofibrils. As such, its representative physical or mechanical properties would be measured on different scales, having an array of RVE (representative elementary volume) (Jeronimidis 2013). In contrast, engineered materials such as ceramics, plastics or metals, have considerably small RVE of few  $\text{mm}^3$ , where the material sub-structure plays a minor role. In the same way, building structures are conceived in hierarchical discontinuity where structure, component and material are distinct and independently considered (Knippers and Speck 2012).

The design of *LifeObject* is considered on six levels of hierarchy, from the fibre to the overall system [Figure 11]. Although taking place on different order of magnitude than biological materials, its hierarchical design can be described from the structural macro level, through the meso level of components to the nano-level of fiber itself. The different layers are interconnected, with design parameters on each level that determine its performance, informing adjacent levels of hierarchy and affecting the overall characteristics. Starting from the lowest level, the fibre is in itself a spatial organization of filaments either flat or twisted, in different grades. It is knit (for aramid fibers) or braided (for fiberglass fibers) in different patterns to form the fabric of the micro level. Moving upwards, it constructs a composite material for the tubular components of the meso-level. With FM embedded in its fabrication process, the tubular elements are made of para-aramid fibres manufactured by knitting, with variation of different parameters such as machine types, needle density, pattern and more, to reach different performative requirements (Blonder 2016) These are interlaced in space in relative compression, making a structural volume. The macro level of the structure is designed by a parametric algorithm that populates required global volumes with components of the meso-level, in an iterative process, resulting macro level is free-form porous volumes of airy components.

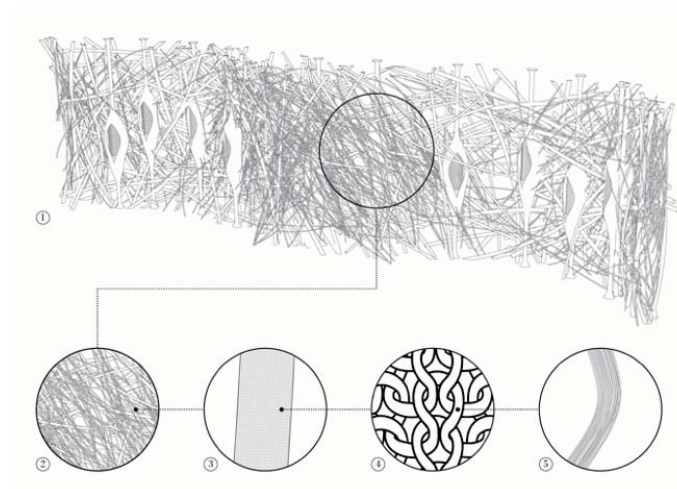

Figure 10. Hierarchical construction of *LifeObject* material system

## Low Energy Synthesis

Biological materials are formed by low-energy processes. Standing in contrast to fabrication processes of engineered materials, living matter is mostly synthesized in ambient temperatures and under low atmospheric pressure, in an aqueous environment (Meyers et al. 2011). Biological materials essentially consist of a small number of light and simple building blocks (C, H, O, N, P, S, P, Ca, etc), and only a few polymeric substance groups (proteins, polysaccharides, lipids, nucleic acids, etc) exist (Dunlop and Fratzl 2010). The building blocks of biological materials, such as proteins, lipids and carbohydrates, are formed in a process of biosynthesis, also called anabolism. Complex molecules are formed out of relatively simple compounds in metabolic pathways, a chain process of chemical reactions catalysed by enzymes. The typically weak building block of biological materials favour the subdivision of load bearing task into as many sub-elements as possible, achieving efficiency through redundancy. The heterogeneity displayed between the multiple elements of biological structures enables the multiplicity of load paths within the structure, contributing to its resistance to crack propagation (Jeronimidis 2013).

The fabrication process of the components of LifeObject is too based on the principle of low-energy synthesis, all along the process from shaping to curing. With FM embedded, it relies on the self-organising capacity of its material, being a fabric. The relative movement between the fibres that constitute the fabric, allow it to self-organise in reaction to external forces, into complex forms. As opposed to traditional forming processes of composites, no rigid mould is involved in the forming of the elements. Rather, it follows the architectural tradition of form-finding, as developed by Frei Otto, where structural stability is achieved by self-organisation of the material system under external forces. Enhancing its fabric materiality, the textile sleeve is suspended, formed by tension and gravity. Thanks to the stretching qualities of the knit fabric structure, allowing self-organisation, and the formation by tension, the resulting components are all similar but varied. Visually resembling a branch, or a bone, the LifeObject components self-organize under stress, their morphology resulting from the loading by tension and material properties, adapting to forces according to boundary conditions. While composite materials are normally formed with the use of costly moulds, in high-temperature ovens or under pressure of vacuum of autoclave (Mallick 2008), these elements are manufactured manually, in low temperature curing, not requiring moulds. The fabric sleeves are impregnated manually with resin and then formed hanging over a frame [Figure 12]. Curing is done in ambient temperature, supported by a short passage in an improvised outdoor oven of 40°. The manual fabrication of the elements requires minimal resources and introduces craft qualities and slight variations into the final product.

Like biological materials, The LifeObject structure is also composed of a small number of weak, simple and light building blocks. Only five types of elements (3 of fibreglass braiding and 2 of knit para-aramid) were used for its construction, all extremely light and requiring relatively low energy for their fabrication. The low density of the elements, with cured material that weighs approximately 150 gr per linear meter, made it very easy to manipulate. This directly affects the ease of assembly and construction of the structure, being itself a type of low-energy synthesis, at it requires only man power, no lifts or heavy tooling. The whole structure was assembled on site by a small number of non-qualified workers in only three days.



Figure 11. Fabrication process: shaping and curing not requiring moulds

### Self-organisation

Biological structures are assembled from the bottom-up, as a necessity of the growth process, since no overriding scaffold or external direction is involved apart from the environmental stress. The notion of spontaneous, dynamically produced adaptive organisation of the natural world has been defined as self-organisation. Natural materials develop under load, and the internal intricate organisation of biological materials, structures and organs are the evolutionary response to external forces, or the performative response to specific loading (e.g. local stress on a bone area) (Weinstock 2006a). Biological self-organisation is essentially geometrical; simple components are self-assembled into complex three-dimensional assemblies that have emergent properties and behaviour. Such property could be its mechanical behaviour, such as the reaction of linear stiffening that occurs in a tissue (e.g. the human skin), increasing its stiffness as stress increases (e.g. pinching of the skin). Such emergent behaviour requires a certain redundancy on the lower level of organisation (Weinstock 2006b). The ability for self-assembly of the living organism includes management of self-configuration, ability for self-optimisation in changing environmental conditions and the ability for self-repair/healing.

The negotiation between top-down pre-determined factors and bottom-up evolution of the structure is reflected on various levels of hierarchy, in the design, fabrication and construction processes of the LifeObject. The design code combines random elements with pre-set values. The pseudo-random distribution code is informed by the figures extracted from the algorithmic analysis of the nest, setting global relative distribution of material in the volume. Curves are placed within volume boundaries by an iterative process, controlled by the numeric values, assuring a material distribution that refers to the structure of the nest, both in orientation and in quantity. Floor-to-ceiling elements are interlaced with component-to-component ones; stoppers are placed at critical intersection points between the elements. Each run of the code will generate a different phenotype expression of the common genotype, reflecting its characteristics of self-organization. The bottom-up assembly of the LifeObject resembles the bird's construction procedure, or a natural growth process, rather than a typical architectural one; the structure is stable at all points during construction process, not relying on scaffolds or temporary supports of any kind. External control is minimized, with a minimal configuration of components that is defined in space, following the global volumes planned. Respecting the numeric values of the code, components are then gradually placed in space, freely, contracting each other by tension, building up stability and affecting the overall configuration of the structure.





## **Adaptability**

Biological systems adapt to their environment, and develop under load. During growth, biological systems actively respond to external stimuli and form architectures and microstructures with improved functionality. The microstructure of the wood cells, for example, strongly depend on its loading conditions, varying from square shaped to circular shaped on upper and lower parts of the branch, according to it being under compression or tension. Flexure is the common way of loading in biological systems, sustained by the organic components of the material that have a variety of structures and present anisotropic multi-axial properties. The stochastic process of small random variations, which are repeated over time, assures the robustness of natural system; small variation in the key to such processes. (Weinstock 2006b).

The global complex form of the bird's nest is achieved by adaptation to forces; the twigs are pressed in compression, forming curving shapes that together form the overall structure, with no additional gluing materials. The overall free-form porous volumes of LifeObject are achieved by the adaptation of its component to bending forces; pressed in between ceiling and floor, or interlaced, components deform into curve-like forms, applying mutual forces that form and maintain an overall stable structure. The structure relies on the capacity of the elements to withstand deformation without reaching failure. Material parameters, such as mixing ratios of standard and flexible resin, are controlled in combination with geometrical parameters such as proportions and distribution of 'stoppers' along the element, to achieve the required flexibility and strength.

Adaptation to forces appears as forming principle both on lower and higher levels of hierarchy of the material. On the lower level, it defines the component's shape as it is formed freely by the fabric's self-organization under tension. On the global level, it guides the construction process as it is growing from the bottom-up with partial determination, reacting to the local development of stress by the overall interactions between components.

## **Conclusions**

The integration of Fabric Materiality in the design and fabrication of FRP architectural elements enables the sustainable implementation of biological design principles, as demonstrated through the LifeObject case study. The inherent properties of textiles identified as the main attributes of FM, such as self-organisation and resilience, naturally coincide with the alternative approach suggested by biological models. Relying on the fabric qualities of the material enabled the sustainable implementation of principles extracted from the biological model of the nest, both as numerical values and as general principles of material, structure and construction process.

Inherent to all biomimetic design processes, substantial differences lie between the biological model and the target designed structure; difference in performance requirements, typical users, form, tools and materials imply a careful selection of relevant principles and data for application. Here, the principles applied generated a structure of extreme lightness and resistance, self-supporting and resisting several parallel lateral loads, with a density of 10kg/m<sup>3</sup> only. Lighter than feather, it is a volumetric construction, in between material and structure, as it is typical for biological materials where material and structure are non-discernible. The application of biological principles through FM suggests a porous FRP matter-structure, with resilient characteristics. Redundancy, variation and the achievement of complex morphology through the adaptive assembly of simple components are qualities of potential significance for the architectural field, which could favour the wider application of FRP in the field. The suggested alternative approach and techniques, as well as the matter-structure itself, require further elaboration and examination for a deeper understanding of the potential these offer to architectural applications.





## Acknowledgments

"The LifeObject" installation was realised as part of a collaborative project of the Israeli pavilion for the 15th Venice architecture biennale, with architects Ben Bauer, Noy Lazarovitch, curator Dr. Yael Eylat Van-Essen and biologist Dr. Ido Bachelet.

## References

- Blonder, Arielle and Grobman, Y., "Natural Complexity - Embedded Fabric Materiality in Fibre-Reinforced Polymer Fabrication", in . Herneoja, Aulikki; Toni Österlund and Piia Markkanen (Eds.), Complexity & Simplicity - Proceedings of the 34th eCAADe Conference - Volume 1, Pp. 581-589. Oulu, Finland, August 2016.
- Blonder, A. and Grobman, Y.J. , "Design and Fabrication with Fibre-Reinforced Polymers in Architecture: A Case for Complex Geometry". *Architectural Science Review* 59(4): 257–268. 2016.
- Collias, Nicholas., "Engineering Aspects of Nest Building by Birds". *Endeavour* 10(1): 9–16. 1986.
- Dunlop, John W. C., and Peter Fratzl., "Biological Composites". *Annual Review of Materials Research* 40(1): 1–24. 2010,
- Fernandez, John., *Material Architecture: Emergent Materials for Innovative Buildings and Ecological Construction*. Boston: Routledge. 2005
- Hansell, Mike., *Bird Nests and Construction Behaviour*. Cambridge University Press. 2000  
*Built by Animals: The Natural History of Animal Architecture*. Oxford: OUP Oxford. 2009
- Healy, Sue, Patrick Walsh, and Mike Hansell., "Nest Building by Birds". *Current Biology* 18(7): R271–R273. 2008.
- Jeronimidis, George., "Structure-Property Relationships in Biological Materials". In M. Elices, ed *Structural Biological Materials: Design and Structure-Property Relationship..* Pergamon, 2013.
- Knippers, Jan, and Thomas Speck., "Design and Construction Principles in Nature and Architecture". *Bioinspiration & Biomimetics* 7(1): 15002. 2012
- Mallick, P. K., *Fiber-Reinforced Composites: Materials, Manufacturing, and Design*. 3rd ed. Boca Raton, Fla: CRC Press. 2008
- Meyers, et al. "Biological Materials: A Materials Science Approach". *Journal of the Mechanical Behavior of Biomedical Materials* 4(5). Special Issue on Natural Materials / Papers from the Third International Conference on the Mechanics of Biomaterials and Tissues: 626–657. 2011
- Milwich, Markus, et al. "Biomimetics and Technical Textiles: Solving Engineering Problems with the Help of Nature's Wisdom". *American Journal of Botany* 93(10): 1455–1465. 2006
- Parascho, Stefana, et al., "Modular Fibrous Morphologies: Computational Design, Simulation and Fabrication of Differentiated Fibre Composite Building Components". In *Advances in Architectural Geometry 2014*. Philippe Block, Jan Knippers, Niloy J. Mitra, and Wenping Wang, eds. Pp. 29–45. Springer International Publishing.
- Weinstock, Michael. "Self-Organisation and Material Constructions". *Architectural Design* 76(2): 34–41. 2006a; "Self-Organisation and the Structural Dynamics of Plants". *Architectural Design* 76(2): 26–33. 2006b



Percolation Printing - Defining volume through time and viscosity to create non-layered volumetric prints  
Melanie Daguin, Sheila Lin, Oluwabunmi Fayiga

## Percolation Printing

Defining volume through time and viscosity to create non-layered volumetric prints

Melanie Daguin<sup>1</sup>, Sheila Lin<sup>2</sup>, Oluwabunmi Fayiga<sup>3</sup>

<sup>1</sup>Princeton University, <sup>2</sup>Princeton University, <sup>3</sup>Princeton University

<sup>1</sup>mdaguin@princeton.edu, <sup>2</sup>sheilalin@princeton.edu, <sup>3</sup>ofayiga@princeton.edu

**Abstract.** We explore an approach to creating formal elements with natural aggregate and silicone rubber resin through an embodied design process. Divided into four parts: actuation, sensing, interface, and simulation, our intention is to understand the rubber-rock formations not just as the objects they represent but as a product of calibrated tools, isolated and measured material properties, and iterative design workflows. Through numerous material tests, observations, and data gathering, a calibrated workflow is achieved. The result is an autonomous, hands off design process capable of yielding any natural aggregate form bound by silicone resin, generated top down using gravity and inherent material properties to dictate percolation flow.

**Keywords.** *Augmented Materiality; Actuation; Aggregate; Architecture; Robotics.*

## Introduction

The flexibility of malleable mediums such as resin, latex, and silicone have provided users with a wide range of possibilities for aesthetic and formal innovation; however, their relationship to digital technology within the field of architecture has remained open-ended. With the increase of experiments in architecture schools and practices testing the potential of viscous materials to create form, it becomes imperative to recognize the parameters inherent to these mediums and the ways in which to use them precisely. A novel and unique form of 3D printing is enabled when these parameters are defined.

As described in *Design Approaches Through Augmented Materiality and Embodied Computation*, augmented materiality “can be understood as a means to imbue material craftsmanship with the qualities of digital fabrication such that algorithmic and robotic control act as additional material attributes”. Our intention for these experiments is to allow for the inherent properties of natural materials to inform the project’s framework. Time and viscosity of the silicone rubber resin material determine the length of the structure created, and the surface tension of the rock becomes its own scaffolding. As such, natural materials have their own sense of agency.

## Related Work

Our interest in granular structure was informed by Gramazio Kohler’s “Rock Print” at the ETH in Zurich. In its final stage, the project successfully displays a large-scale rock formation in which the wood scaffolding initially containing the rocks is removed, revealing an aggregate structure that is held together only by layers of string that were placed between each rock layer at the time of construction. As an alternative to their process of jamming to create a reversible structure, we were interested in eliminating the process of layering and creating permanent forms built from top down instead, using gravity as well as the material’s natural properties to arrest a desired form in space and time.



## Initial Research

We began by combining soft bonding agents with granular materials to achieve desired permanence. Initial tests included mixing different ratios of sand and rocks with tacky glue, hot glue, latex, and water in hopes of achieving a homogenous mixture that not only adhered to the surface of the aggregate but also bonded the interstitial space between its individual granules. This research, in tandem with our preliminary studies, aimed to understand the material product as a combination of aggregate materials within a binding matrix.

Because we were committed to using a flexible matrix liquid, we decided to use a silicone rubber compound resin from Smooth-On (Oomoo® 25) which did not require oxygen but rather, the combination of two equal parts to cure. The resin only needed 75 minutes to solidify, allowing time for it to move through the rocks while decreasing the wait time before removal. However, the material still retained the physical properties of latex in its inherent resilience and malleability.

## Process Overview

The aim of this project is to develop a calculated inverse 3D printing method, where rocks are the medium for which liquid silicone resin percolates through at a speed dictated by a peristaltic pump in relation to time to create free-standing wall-like structures. The final product is dependent upon the actuation of the peristaltic pump, sensing the ratio of both parts of silicone resin mixture, and using grasshopper as our interface for controlling an ABB robot which will create the goal geometry accurately.

### ***Actuation: Peristaltic Pump***

Using a two-part silicone resin required a regulated actuation method that allowed for each part of the resin to flow at an equal rate and blend into a homogenous mixture that ultimately activated the curing process. In order to achieve this, we chose the peristaltic pump as the method of mechanically inducing air pressure and suction to transfer each part of the resin from one receptacle to another. To facilitate the mixing of parts, a 3D printed piece was attached to each tube and connected to a two-part mixing nozzle (figure 1). The nozzle ejected a pre-mixed combination of parts, which allowed us to bypass the manual stirring process and replace it with a mechanical solution that not only delayed the chemical curing process to the exact moment of ejection, but ultimately increased the pot life, or curing time, of the silicone.

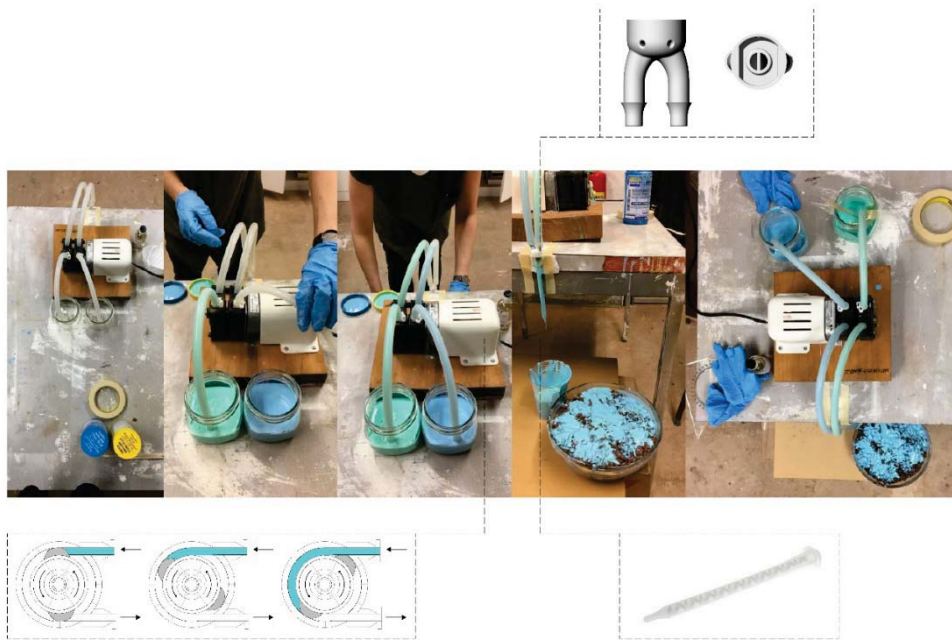

Figure 1. Pump setup. Top right: nozzle connector designed by Nicholas Foley of Greysheed for the Rob|Arch 2014 conference.

### Sensing: Flow Regulating "Seesaw" Device

The end product showed potential for structural properties within the rocks and silicone, but inconsistencies in the curing of the resin suggested that the actuation method did not always produce an equal ratio of part A to part B. We observed that the high viscosity of part B (represented in green) slowed its flow through the tubes, and thus our mixture exhibited a greater amount of part A (represented in blue) which corrupted the curing process. It was imperative to design a method of regulating the flow rates of each part to ensure a perfect mixed ratio; therefore, we supplemented our actuation setup with a simple seesaw mechanism that used the weight of both liquids to mitigate flows (figure 2). Ultimately, we found that the rate of flow from both parts could be controlled by pinching the part A (blue) tube at two points with C-clamps, and thus it was not necessary to employ the seesaw device.

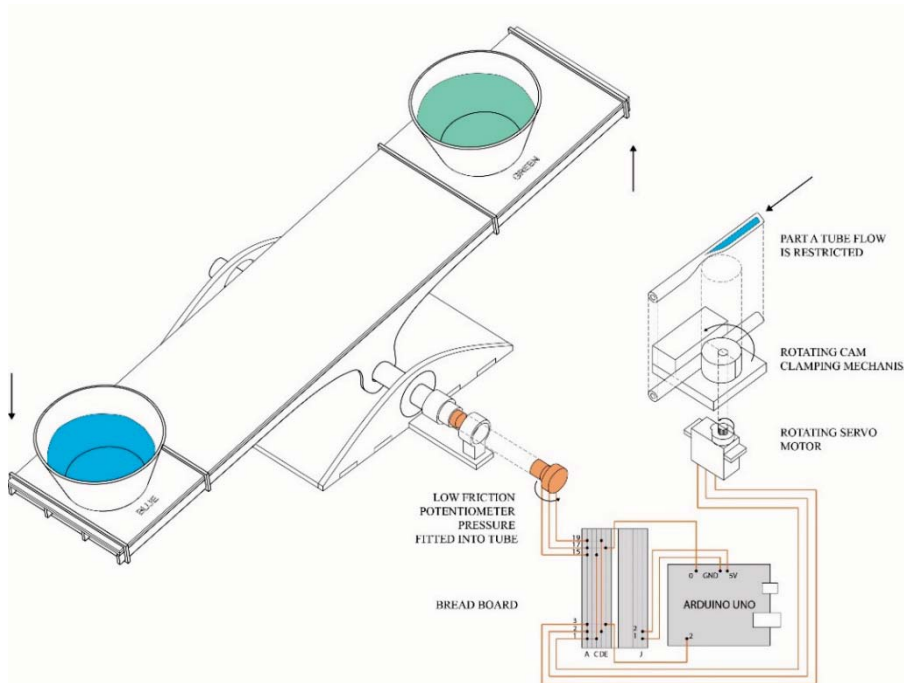

Figure 2. Seesaw at equilibrium.

### Material Tests

Our many iterations of experiments aimed to determine what combination of factors would allow the resin to reach the greatest depth and create the strongest structure. In each test, we set up parameters to isolate significant variables. We experimented with holding the nozzle at a smaller number of points for longer periods of time, but found that it was more effective to hold it at many points for shorter periods of time. We experimented with moving the nozzle back and forth along the path to make the structure taller, but found that the resin would just begin to cure and pool at the surface of the rocks. Ultimately, we changed our rocks to a larger size and found that increasing interstitial space within the structure would allow the resin to achieve the most depth.

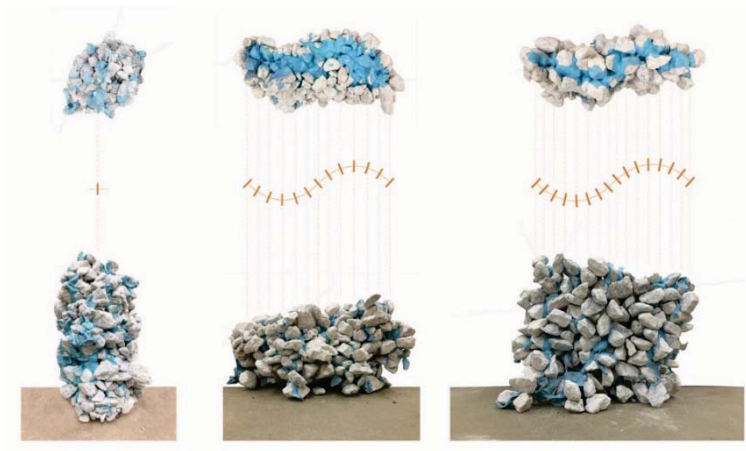

Figure 3. Iterative experiments.



### Isolated Tests

Our initial material tests brought us to the conclusion that the most significant relationships to determine were between pour time and depth and the time of tilt after pouring. It was clear that large rocks would yield results with greater height, but because the white marble chips we had been using may have been too heavy and/or slippery, we switched to large black volcanic rocks with coarse, porous surfaces that could absorb the resin more effectively. In order to isolate the exact result of each pour time, we set up a series of sectional material tests that would allow us to visually examine the percolation process. With the use of transparent cylinders and layered acrylic, we were able to effectively visualize the depth of percolation as well as the effect of tilting the final product after the silicone had percolated through. The variables we had measured from these isolated experiments were used in our final manual test, and it proved to be a successful prototype of our data collection.



Figure 4. Sectional test measuring pour time to depth (left); sectional test measuring pour behavior after tilting (right).

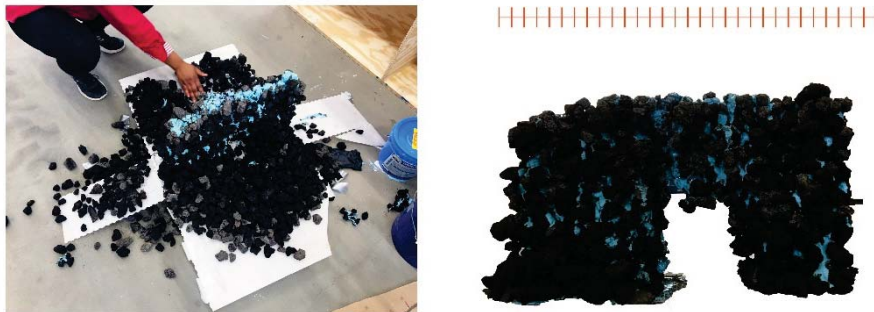

Figure 5. Final manual test.





## Software and Workflow Specifics

### Data Extraction and Implementation

The numerous tests carried out in the first half of the project were an attempt to isolate and control all the variables that we believed could affect the makeup of our final product. Our material investigation culminated in the conclusion that the strongest, most slender structure with the most vertical height could be achieved by incorporating large, light and porous rocks in combination with extended pour times and low repetition. With these variables fixed, we were able to start extracting numerical data from our tests and start the computational portion of the project. The final "arch" test (figure 6) allowed us to effectively express the relationship between time of pour and depth of silicone percolation through the rocks (figure 7). This final test was the foundation on which we based our workflow to recreate the simulated "goal" geometry with rocks and silicone.

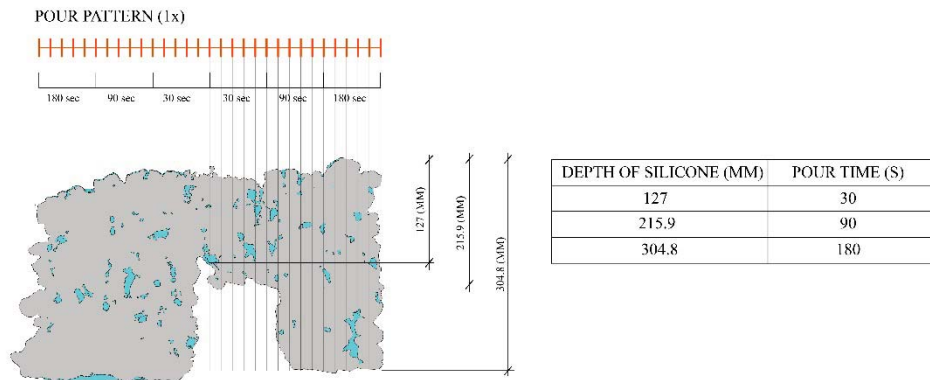

Figure 6. Arch test data.

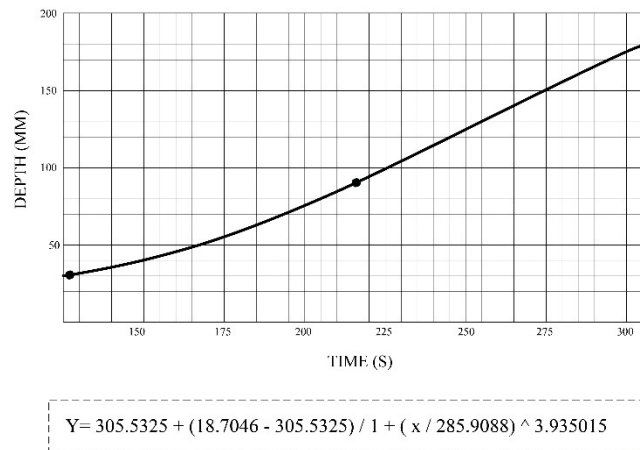

Figure 7. Expression and graph extracted from arch test in figure 6.

## Interface

As a first step in the workflow, the user defines a goal geometry, composed of one planar (top) curve and a (bottom) curve with potential sectional variation. After these two curves are established, the script divides the top curve into 10 mm increments, representative of the appropriate distance between pouring points derived from our material tests. Next, each subdivision is translated into a vector that connects the two curves to create a “goal” geometry. The direction of these vectors inform the angle of tilt of rock container; because the material requires gravity in order to flow, the container of rocks is tilted perpendicular to the ground so that the angle of that particular subdivision is executed by the force of gravity on the resin.

The length of the curve subdivisions within the goal geometry is coded to indicate the time of silicone poured at a specific point into the aggregate. (figure 8). The workflow then translates the robot’s motion in time into RAPID code which is used to power the ABB robot.

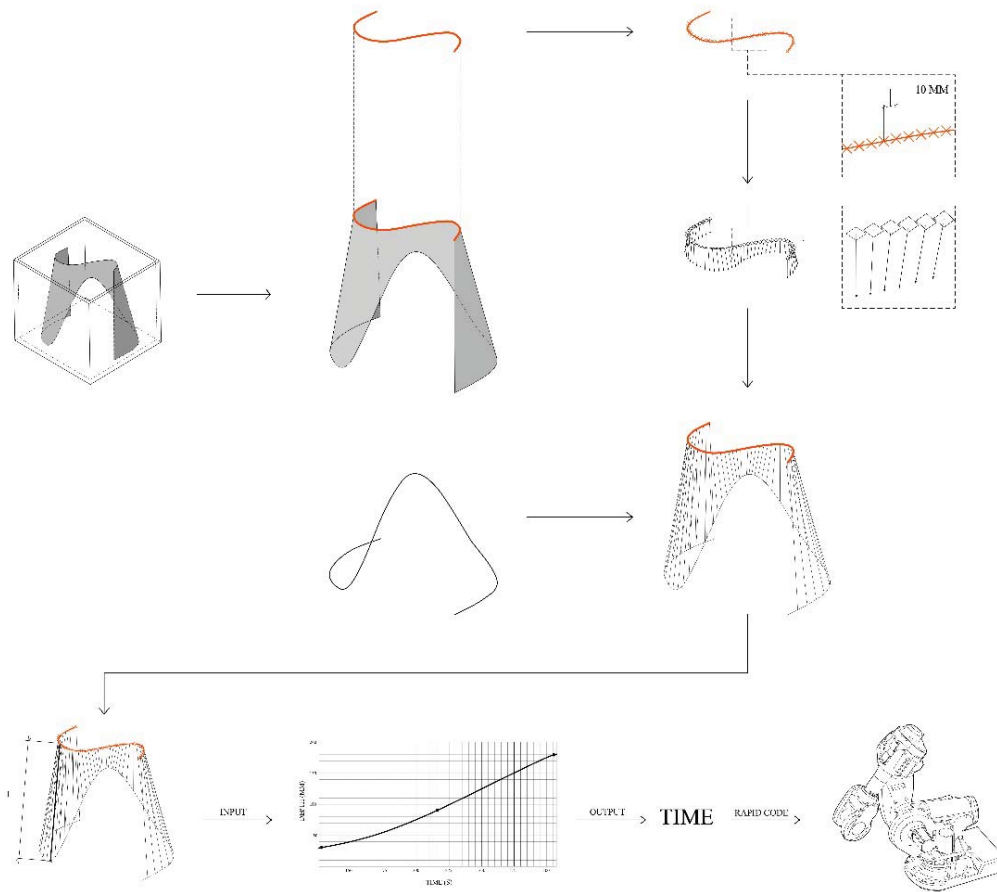

Figure 8. Workflow diagram explaining interface and translation to robot software.

The result is a script that allows almost any ruled surface that does not exceed the rock's angle of repose to be built. It intuitively determines the angle of tilt and time spent at each point along the surface depending on the function extracted from our earlier material tests.

### Simulation

Before simulating the RAPID code, we welded a steel box of L-channels together and added extra horizontal and diagonal bracing for structural support. The use of steel was essential in ensuring that the weight of the aggregate could be securely supported by the robot. The end effector was attached to the robot and positioned just below the mixing nozzle. As quaternion coordinates describe only orientation and not position, the stationary nozzle and end effector were calibrated manually using the 4-point TCP calibration process with RAPID code, generated through MUSSEL (developed by Ryan Luke Johns at GREYSHED and Princeton University School of Architecture). In defining the relationship, the end effector was defined as the work object and the stationary nozzle point as the tool.



Percolation Printing - Defining volume through time and viscosity to create non-layered volumetric prints  
Melanie Daguin, Sheila Lin, Oluwabunmi Fayiga

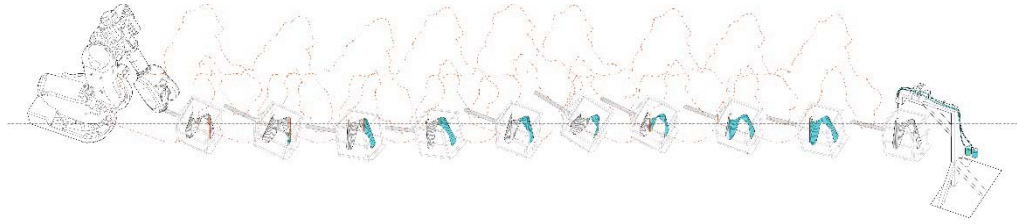

Figure 9. Simulation diagram.

The geometry of the goal surface was designed with planar as well as sectional variation to fully challenge the precision of the script. The final product proved to be a successful exemplification of our data collection, effectively recreating the geometry we had loaded into the script (figure 10). The height of the arch in the center as well as the tapered slope of the external surfaces on each side of the arch demonstrated that our script was an accurate depiction of the relationship between the time and speed of pouring relative to the depth of the rock-silicone formation that was produced.

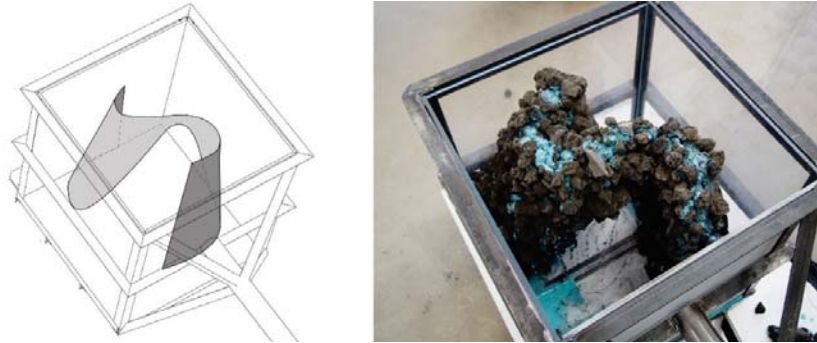

Figure 10. Final Product

## Conclusions

Our series of experiments and simulations strive to disrupt the traditional dynamic of the digital tool as design agent and the material as mode of production. It grants natural materials their own sense of agency and allows for digital technology to merely enhance the generative forms that they already possess. Percolation Printing strives to achieve the effective intersection of craftsmanship and computation and combines the two to create a more autonomous design process based on the inherent material properties of natural aggregate.

## References

- "Rock Print" For ETH Zurich Institute of Technology in Architecture. Gramazio Kohler Research (2014).
- Johns, R., Foley, N. and Kilian, A. "Buoyant Extrusion: Design Approaches Through Augmented Materiality and Embodied Computation" For: Rob|Arch 2014. GREYSHED and Princeton University (2014).
- Keller, S. and Jaeger, H. M. "Aleatory architectures" In: Granular Matter. Springer (2016), 29.



## Flips + Drips:

### Multi-Material Deposition Augmented Through Tactile 1:1 Volumetric Modeling

Ryan Barney<sup>1</sup>, Lukas Lesina-Debiasi<sup>2</sup>, Kevin Pazik<sup>3</sup>

<sup>123</sup>Princeton University School of Architecture, USA

<sup>1</sup>rbarney@princeton.edu, <sup>2</sup>ldebiasi@princeton.edu <sup>3</sup>kpazik@princeton.edu.

**Abstract.** Advances in digital modelling and 3D printing have increased the speed, resolution, and material control in which objects may be designed and fabricated. However, these tools have simultaneously disassociated digital design with the physical constraints of fabrication such as scale and a tactile sensing of materiality. The work presented in this paper combines a pneumatic deposition system, computer vision, physical modeling units, sensory feedback, industrial robotics, and an augmented reality interface towards an intuitive, 1:1 multi-material deposition and fabrication process. We present an interface in which models are designed through physical blocks of fabrication material, with varying physical properties that can be tactilely understood before being applied to a built design. This project seeks to challenge the current paradigm within architectural design and fabrication, where objects are created in a material-less digital vacuum before being exported into the physical world in an array of scalar versions through materially indifferent manufacturing techniques. Additionally, this project looks to remove predetermined tool paths in favor of a unified design and fabrication process where design decisions can be updated while fabrication is in progress.

**Keywords.** *Tactile Modelling; Volumetric Modelling; Multi-Material Deposition; Augmented Materiality; Embodied Computation*

## Introduction

This project seeks to break with a dominating tradition of design as a linear process which terminates with a simulacrum of a digital model. We instead argue for an open-ended play between the designer, interface, material constraints, and the manufacturing technique. The current state of computer aided design (CAD) assumes a wholly digital interface as the primary space of design, separate from computer aided manufacturing (CAM) which takes on the role of translation and replication of digital objects into the physical world. This process relies on the geometric precision of a digital model developed in an interface that requires little to no relationship to the physical and material constraints of manufacturing processes.

The overall setup of the project consists of an original design for a pneumatic deposition system used to dispense various rigidities of an expanding polyurethane foam. A 3D scanner reads the topography of the deposited material, and sends this data to an augmented reality interface, inside of which the designer can iteratively design a 1:1 full scale object. By constructing a voxel model out of material samples inside of the augmented reality space, the material samples trigger the deposition of varying foam mixtures, physically connecting the designer and the digital model during fabrication. Moreover, a sense of unpredictability is maintained by this process as each deposited unit of uncured material grows via positive gravitropism, giving the final form a “drippy” aesthetic.

This workflow embodies a process of form generation integrated with the very process which produces the fabrication script. Still embracing the virtues of digital manufacturing techniques, this





project looks to remove the predetermined tool path and modeling at an overly abstracted scale, in favor of a more integrated design methodology where the model and the respective fabricated object are integrally linked throughout the design process. We propose a design methodology that does not rely on the replication of digital material-less objects, but rather embeds material constraints as active participants in the design process. The interactivity of the design schema creates an editable workflow that adapts in response to its embedded feedback loops. This work is a development of contemporary design research into interfaces which guide material form over time.

## Related Work

A precedent series of studies that this work looked to was the body of work generated by Gramazio Kohler's robotic fabrication experiments at ETH Zurich in Switzerland. In particular, their project titled "The Foam" was helpful in its demonstrations of how an extruded polyurethane foam could be deposited, resulting in a loosely controllable form with inherent complexity and potential for variation through manipulation of a handful of digitally controlled parameters. Our work differs from Gramazio Kohler in that we abandon the predetermined tool path which their work depended on, while also adjusting the form of the foam post-deposition using positive gravitropism as opposed to negative.

This project also sought inspiration from the mediated matter group at MIT, particularly with regards to the pneumatic biomaterial deposition projects headed by Neri Oxman. The team's explorations provided great insight into the potential for pneumatically controlled printing of complex forms out of biomaterials embedded with properties that are calculable and predictable, while simultaneously ensuring a degree of unpredictability that can be iteratively built upon.

The challenge to the negative gravitropism of expanding foam is in line with work by the University of Applied Arts Vienna and University of Innsbruck entitled "Robotic Infiltration", in which phase-changing polymers were pulled using two industrial robots in the production of full-scale structures. Our work is different, however, in the use of one robot working collaboratively with the designer, as opposed to their use of two robots.

Moreover, 3D scanning and augmented reality as components of a design interface are not used explicitly used by these predecessors. This work falls in line with a family of projects developed by Axel Kilian and Ryan Luke Johns at Princeton University, where the computational aspects of a design process are 'embodied' given our material's embedded tendencies and the physicality of tactile modeling units.

## Design Workflow

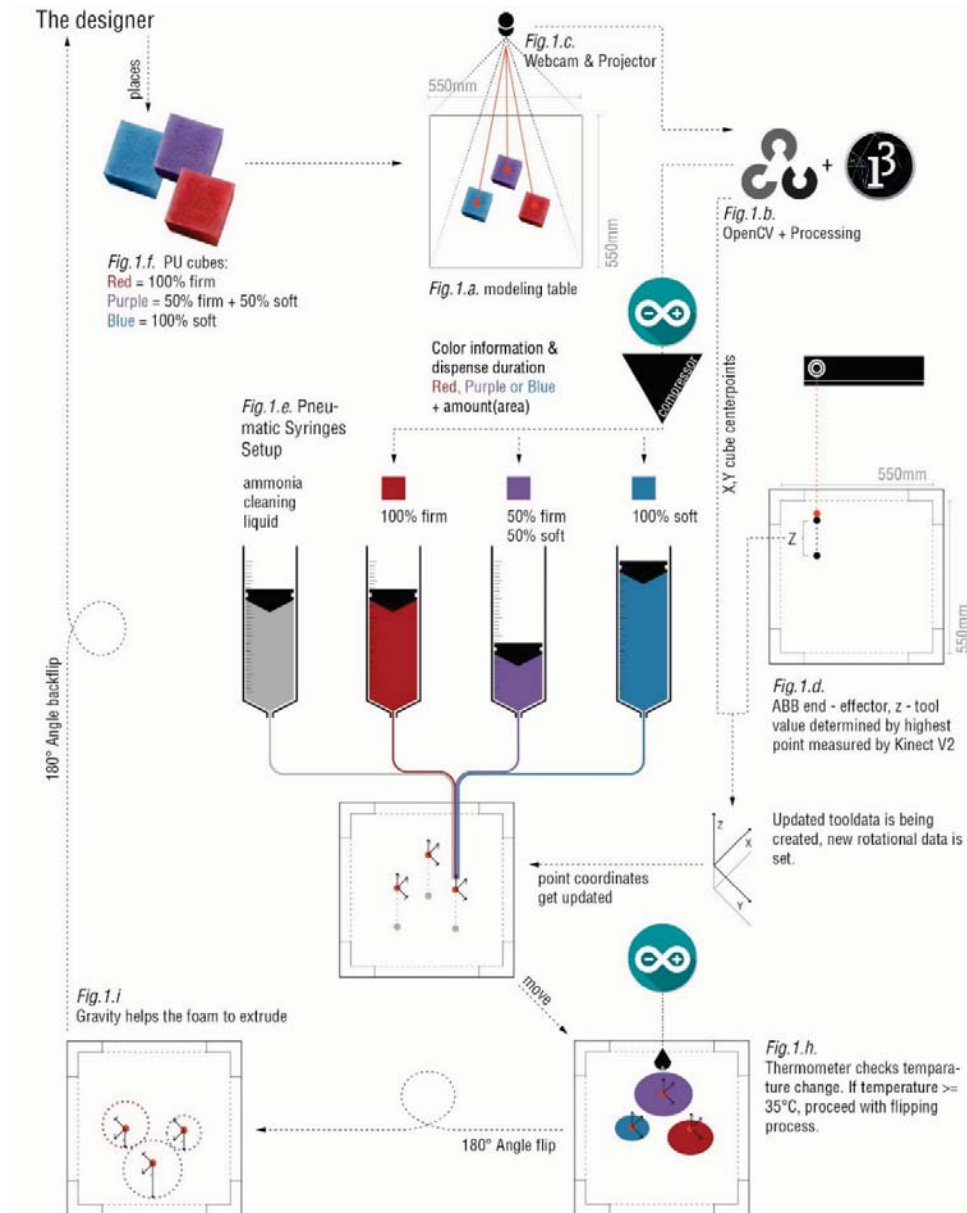

Figure 1. Workflow Diagram.

- Initially the designer is confronted with an interface consisting of a small table, proportionally identical to the build plate mounted on an ABB IRB 7600 robotic arm, allowing for a 1:1 scale design and fabrication process. This table displays the design progress and is the main space of interaction for the designer.

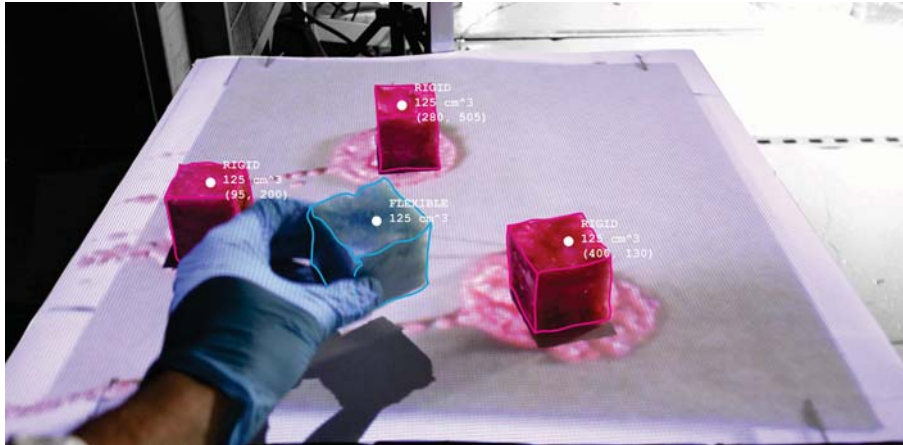

Figure 2. Colored Material Sample Cubes placed on the Augmented Reality Modeling Table.

- Colored material sample cubes of expanding polyurethane foam are manually placed onto the modeling surface [Figure 1.a.] [Figure 2]. The cubes represent three different mixtures with corresponding colors (100% Rigid, 50%Rigid 50%Flexible, 100%Flexible). The polyurethane foam mixtures consist of two parts, mixed at different ratios for rigid and flexible versions (1:1 and 2:1 respectively).
- A camera mounted above the table records the location of the cubes on the table and feeds the images to a computer that runs a Processing + OpenCV script [1][2][3]. The blocks are detected through blob detection and the centroids of each cube in plan become the starting points for the updated robot tool path [Figure 1.b.] [Figure 3].
- When ready, the user 'saves' the position of the blocks which are stored into memory. The X and Y coordinates of the blocks relative to the modeling surface are matched with a corresponding Z coordinate from a 3D scan received from an Xbox Kinect V2 sensor mounted above the build surface [Figure 1.c.] [4]. This set of Cartesian coordinates is then translated into the coordinate system of the ABB arm, and the deposition process begins.

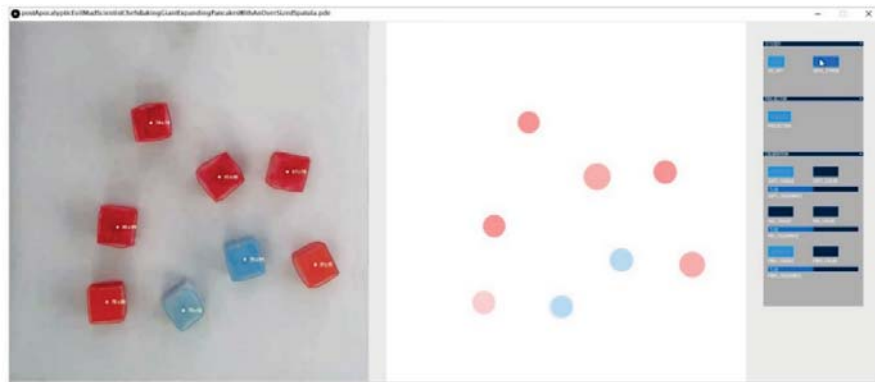

Figure 3. Digital Interface, detecting and saving block coordinates for deposition.

- The build plate is then driven under a depositing station which uses a series of pneumatic syringes mounted on an aluminum frame, each containing a different part of the two-part expanding polyurethane foam mixture or a cleaning solution (one part ammonia to three parts water [Figure 1.e.] [Figure 4]).
- A 1.5hp air compressor, set to 40 psi supplies the air to each canister. 6 ¼" 'normally closed' 12v solenoid valves [Figure 4]). controlled by an Arduino with stacked motor shields (fig. 1.f.) [5]. In order to dispense the correct ratios of parts A and B (100:87.5 parts by weight for rigid foam, 100:57.5 parts by weight for flexible foam) the solenoids were modulated with varying on/off times, fluctuating every few hundred microseconds. To prevent expansion in the mixing nozzle, the cleaning solution was run through the system after every pour.



Figure 4. Foam Deposition in Progress.

- After deposition, the build plate is driven to the sensing station. The freshly deposited material produces an exothermic reaction which is measured by an infrared thermometer [Figure 1.h] [Figure 5]. When the desired temperature is reached (based on how much the designer wants the object to drip), the robotic arm then moves the plate out from under the thermometer, and flips it 180 degrees upside down in an arch with a radius equal to that of the current height of the object.

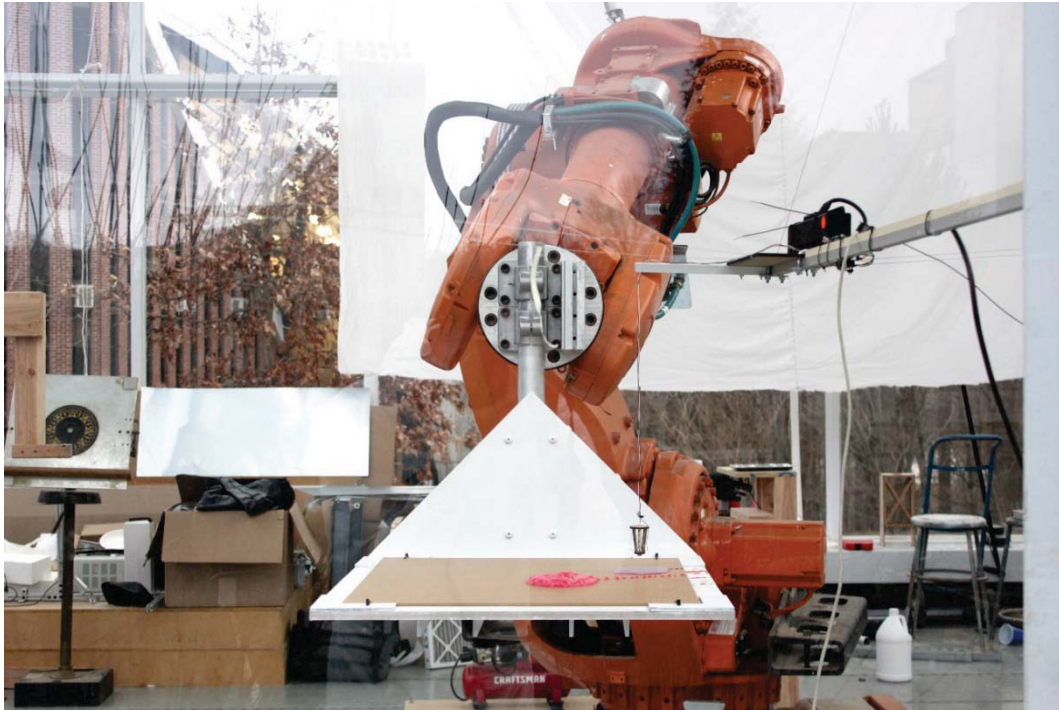

*Figure 5. Sensing the Temperature of the Extruded Foam and Waiting for the Ideal Temperature to Trigger the Flip Process.*

- When done at the correct temperature, the uncured foam, aided by gravity, flows and expands downwards generating dripping stalactite-like forms [Figure 1.i] [Figure 6], manipulating the geometry of the initial volume deposition. Once finished, the build plate is driven back under the Kinect and rescanned.



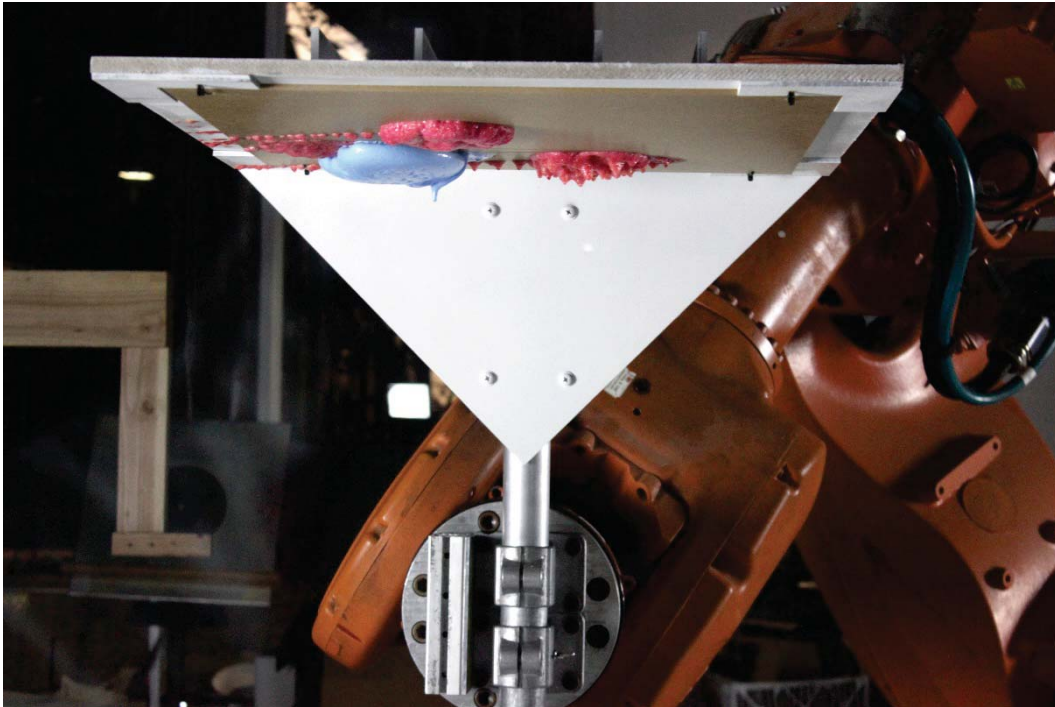

*Figure 6. The Flip of the End Effector causes the Creation of Stalactite-like Forms.*

- As the design is built up, an updated plan view of the deposited material is projected down upon the design interface's modeling surface [Figure 1.a]. The user is given the option to model with either an RGB image, depth map, or a combination of the two, as a modeling aid. This function embeds the capacity for an iterative feedback loop to occur between designer and material as each layer of the deposition is fabricated. After the user reads the scanned image, they then continue with a new series of blocks and the process repeats.

Each iteration offers the opportunity to refine the resolution of the designed object through an iterative process that can continue ad infinitum. Every cycle marks a pause of reflection for the designer [Figure 7], where the state of the piece is evaluated -- thus repeatedly arises the question of the end result.

## Improvements

The current software relies heavily on the use of the computer screen itself, and an ideal workflow ought to be streamlined allowing the designer to never leave the work space. Additional functions could also be added, for example the interpolation of material gradients between block placements. Such an example would require further development of the precision of the pneumatic deposition technique which, for the currently explored experiments, was not as essential. More precisely controlled and calibrated material depositions is an advancement that could be significant for a variety of related projects.

Furthermore, the project is currently limited to modeling instructions in plan. However, being able to build a full three-dimensional low resolution voxel model of material volumes could provide for a fruitful design experiment; a physical version of the voxel model and multiple material printing software Monolith [6]. This would result in two objects after the design process: the object created



to be used as instructions (object as code) and the object which was manufactured from these instructions (the encoded object).

Streamlining the connection between the designer and the designed object in a meaningful way is of utmost importance for future developments of this work. The embodiment of the physical constraints inherent in fabrication is a sector of digital fabrication that requires deeper development. Computer aided design cannot continue to remain apathetic to the physical nature of the objects it produces until a final form is realized. It is particularly important that design processes allow for indeterminacy to reveal potentials in a project that digital design, as it is used today, does not allow for due to its insistence on precision at early stages of development.

## Conclusions

The proposed workflow offers an alternative method of design exploration which moves away from the current paradigm of digital modeling and fabrication as one-way techniques and supports the development of a multi-directional network of design influencers and respondents. By allowing the designer the opportunity to make changes after each successive stage of fabrication, an inherent feedback loop ensures that the designer does not relinquish control over the object, while simultaneously allowing for unknown variables and conditions to alter the design trajectory when desirable.

Unlike conventional design procedures where a form or geometry results from a series of commands (boolean, loft, trim, etc.) with materials applied to that geometry, here, material qualities are predetermined, with form resulting from the material's inherent capacity for variation. The designer's interaction with the instrument of fabrication allows for iterative changes over the duration of the fabrication process. The resulting geometries are specific to the material used, translating 'errors' in fabrication, into avenues for development that could not be known at the outset of the project. This workflow does not understand fabrication simply a means to an end, nor material as receptacles of form, but as crucial agents in the process of design.

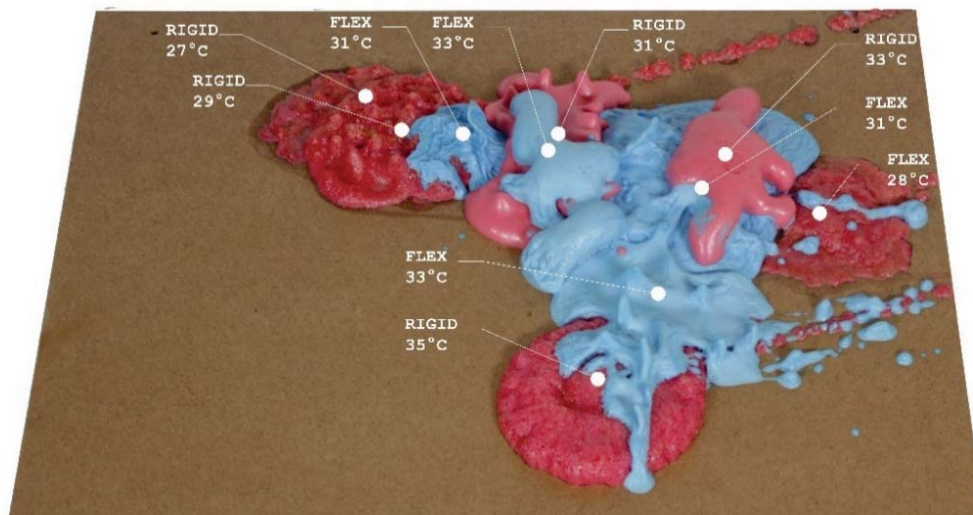

Figure 7. Resulting Stalactite-like Shapes after several Cycles and different Mix Ratios.



## References

Colletti, M., Cruz, M. & Lee, G., 2013. ProtoRobotic FOAMing: REF 2014 submission, London: Bartlett School of Architecture.

Duro-Royo, J., Mogas-Soldevila, L. & Oxman, N., 2015. Flow-based fabrication: An integrated computational workflow for design and digital additive manufacturing of multifunctional heterogeneously structured objects. *Computer-Aided Design*, 69, pp.143–154.

Hack, N. et al., 2013. Overcoming Repetition: Robotic fabrication processes at a large scale. *International Journal of Architectural Computing*, 11(3), pp.285–300.

Johns, R.L., 2013. Augmented Reality and the Fabrication of Gestural Form. *Rob | Arch* 2012, pp.248–255.

Johns, R.L., Kilian, A. & Foley, N., 2014. Design Approaches Through Augmented Materiality and Embodied Computation. *Robotic Fabrication in Architecture, Art and Design 2014*, pp.319–332.

[1] [www.processing.org](http://www.processing.org)

[2] [www.opencv.org](http://www.opencv.org)

[3] [www.github.com/ atduskgreg/opencv-processing](https://github.com/atduskgreg/opencv-processing)

[4] [www.github.com/ThomasLengeling/KinectPV2](https://github.com/ThomasLengeling/KinectPV2)

[5] [www.arduino.cc](http://www.arduino.cc)

[6] [www.monolith.zone](http://www.monolith.zone)





SESSION 02  
HUMAN NATURE  
Alex Haw

*Road Network Design with Space Syntax in Vendas Novas*  
Lázaro Ourique, Carla Patrícia Dias, Iolanda Fernandes



*Extreme cold conditions Architecture: An Antarctica's shelter prototype*  
Diogo Bulhões, Vasco Rato, Manuel C. Guedes



*Architectural Bionics: From Living Nature to Architecture*  
Dmitri Kozlov



*Responsive Spicule Systems: Simulation & Alignment*  
Elias Darham



*Using Generative Design for Evaluating and Improving  
Energy Efficiency in Architecture*  
Catarina Rocha, António Menezes Leitão



*A psychotropic surface based on soft shape changing material  
Emotional input and pneumatically driven actuator*  
Yann Blanchi, Elizabeth Mortamais



*The impact of digital fabrication in contemporary Portuguese architecture  
Witnessing four practical cases*  
Susana Neves, José Beirão, João Rocha







## Human Nature

Alex Haw

Contemporary architecture (perhaps like so many cycles of historical architecture before it) seems to love the study of nature. Yet there is one form of nature whose influence it continually suppresses: human nature.

Why is it that we demote that core aspect which distinguishes a building from a monument – the central role of its active occupant? Why is a human – with all its own manifest evolutionary refinements – so manifestly less influential on the evolution of a design process or form than, for example, a dung beetle or spider?

A strand of design sees bodies as burdens – weights that need gravitational support; heat that needs venting; humidity that needs dehumidifying; nuisances that need purging. Doors have locks to defy our deviousness; windows won't open to defy our dumbness. Sensors replace senses (and sensations) in the automated delivery of a mass-market man-made environment.

Regulations stipulate minimum light levels that will satisfy our optic nerves and prevent a full-scale rebellion of the species, yet architecture seems less interested in the heady resonant power of that light than it might be. Strands of science and histories of art have built vast repositories of knowledge on how light affects and inspires us, yet the best we seem to get in architecture is something like Philip's forays into Dynamic Lighting – with fluctuating wavelengths ensuring corporate corporal wakefulness, keeping the cattle productive. To offer more is to cheat, or transgress; to turn the cathedral into a nightclub, chasing hedonism over decorum.

Sure, the digital age has improved upon the machine age, with individuation, personalisation and the aspirations of mass customisation, proliferate interfaces responding to acutely human triggers: cameras scan our irises and fingers, while floor-tiles oscillate beneath our bodies, shifting in balletic response to our weight. But are these attributes our proudest assets – and the things that make us most human? Do they represent our deepest intrinsic human nature?

There are multiple possible definitions of 'human nature' with which we're all familiar. One core definition accentuates our mental, cerebral capacities – the distinctions of our brain: our capacity to think and feel. How much of our emotional and analytical capabilities do we design buildings for? Do we embrace, stretch and challenge that most human of natures? Legibly and articulately build great theatres of emotions, or lexicons of language and thought and wisdom? If Socrates initiated Western philosophy's investigation into the essence of our human nature, how does an architecture that draws inspiration from nature celebrate or challenge or exploit our innate Socratic urge and ability to reason, rationalise and conceptualise? Or if we allow for the successive Platonic and Aristotelian expansions of humanity to include emotionality and spirituality – do we find architecture confronting and feeding that core cultural aspect of our shared humanity?

In the English language, the phrase 'human nature' can have a despairing tone, negatively suggesting innate flaws; to explain something as "just human nature" tends to expect the worst, not best - whether enunciated by Oriental or Occidental philosophers - whether Hsun Tzu or the Bible. Though Genesis defines man as a distinct improvement on his bestial animal brethren, able to make decisions and act rationally, it also casts him as fallen, sinful, irredeemable; "the Lord saw that the wickedness of man was great in the earth, and that every intention of the thoughts of his heart was only evil."

What a relief, then, to appeal to the progressive human journey mapped by Darwinian Evolution, with plain evidence of genetic progress and clear physical improvement (though evolutionary biologists like Richard Dawkins would again condemn the "selfish gene" underpinning evolution).

Perhaps human evolution is too overwhelmingly impressive as a referent? Too much for architecture to reasonably represent and bear? Perhaps the evolutionary glories of our eyes and brains simply scare us with their complexities – offering unattainable models of performative complexity. Or perhaps we feel, like Islamic iconoclasm, that focusing on human aspects is hubristic, narcissistic, or even fetishistic - and choose to elevate other brethren from the natural world. And perhaps we simply don't know how to imbue a simple history of constructional methodologies with the capacity to best express our thoughtfulness, emotionality and spirituality.

I don't feel this is true. I don't feel architecture is doomed to restraint and silence, nor that it's morally compelled to elevate external systems above its own. I believe architecture, as it has always historically been (i.e. to ignore the momentary and hollow Modernist neurosis that it is engineering), is both functional and artistic; that, like fashion or cuisine, it solves problems – but also creates them, and proposes ideas that push, contest and transgress its limits. It performs and it philosophises. It creates thought in 3 and 4 dimensions, speculating on how we might live. It expresses and explores the core of our human nature, and extends our bodies in the creation of a new, wider, augmented ecology. I'd like to tease out a few examples of how our tiny studio has sought to pursue a human-centred practice that embeds memory and culture, and performs around the human.

When I was starting out, I was struggling for a language; groping with a way to distribute matter that had meaning – that engaged the mind, and demanded unravelling; that repaid attention. I was seeking a way of designing that was emotionally moving but also intellectually stimulating; that catered for the spirits of both Apollo & Dionysus within us all. I was also seeking an innate truthfulness that avoided the distractions, restrictions and egotism of authorship; that used stuff that was already out there, and meant stuff to people, and seamlessly folded it within functional landscapes.

My thesis project at Princeton University (“the DJagram”) extracted the data from a piece of electronic music and wove its geometry around a ‘found’ spiral path on a Manhattan block to create a steadily climbing enclosed urban landscape which cross-fertilised daytime and night-time activities (office and nightclub) in a kind of rigorous, ludicrous, ludic experiment that was part prayer, part protest – partially interesting and entirely implausible and unaffordable. It unwittingly sowed the seeds for the twin engines of my practice, which would go on to work interactively with music within the art sphere, and with buildings in the architecture sphere – both strands unified by an obsession with the human, and a desire to cater for the mind and heart as well as body.

An early collaboration on the installation for a Sound Bed with artist Kaffe Matthews explored the realms of the senses, immersing its visitor in a minimalist structure containing a spectrum of sounds - the subsonic range inaudible, but tactile and somatic. Years later we would design “Arboreal Lightning” for the singer Imogen Heap – an interactive tree that bundled strands of LED light into a trunk that burst from a sound stage and branched over the audience, each pixel activated by their sonic participation via a bespoke software platform we developed called TreeJ. We find ourselves designing a lot of tree-like structures, the motivation for which is the utopian search for efficient structures that morph column and beam with emergent geometry – with full integration of services. “Arboreal Lightning” was sculptural yet mute – dark and unlit and activated only by the active input from people – requiring them to activate it and bring the light that in turn mapped their activity. It celebrated the presence of each attentive audience that is the hidden corollary of any concert, creating the atmosphere.

It emerged out of a longer line of investigations into interaction that centred around surveillance and sensing, requiring the presence of humans to activate them. “LightHive”, at the Architectural Association, mapped all the lights of the institution (representative of the building's latent programme and capacity for use) into a scaled model of smaller lights, which were then activated by any presence in their original reference location to produce an endlessly fluctuating real-time model of occupancy and movement. “Lightfall”, commissioned by the London Underground train network, enabled all the lighting in an underground station to be interactive and responsive,



mapping the movements of commuters moving through its station, encouraging self-awareness and reflection upon one's role within the larger swarm of humanity. "Outreach" – developed at the moment that Microsoft released the Kinect Camera – also mapped human gesture and movement, mapping it to thin, multi-hinged actuated structures with illuminated tips that framed and amplified the complete maximum 3-dimensional volume of possible movement surrounding each body; the celebratory mapping of human movement became a complex mesh of physical systems capped by an undulating cosmos of twinkling dots of light.

I'd also began to feel the limitations of both art and architecture – or at least the depths I could plumb within either – and craved ways to access deeper, more affecting and transcendental human emotions. Partly in order to ensure I occasionally had an evening off work, partly to learn how to cook all the foreign foods that are increasingly the bedrock of English culture (particularly in London), and partly to explore ways to structurally unlock the great social opportunities that cities like London both offer and deny, I created a dining system called Latitudinal Cuisine – a series of weekly events where strangers were invited to homes of people they'd never met to bring a dish from the longitude corresponding to the day of the year – thus scouring 360 degrees of world food in 360 days, scanning afresh a degree a day. One might almost argue that its structure was architectural – rigorous, geometrical, responsive to the contours of the earth yet merging it with human culture; folding the bio-functionality of eating with the pleasures of company and co-exploration; creating a real social space as much as event. During the London Olympics, we designed an extravagant CNC-cut topographical table in the shape of the world, replete with vast vertically stretched mountains, illuminated coastlines, and structural ocean trenches in which one could sit, and ran a pop-up restaurant serving a different slice of the world each night, each night cooked by a different Londoner with hybrid genetic nationality.

Over the years, I've expanded the dinners to last longer – as all-night parties centred around cutting-edge electronic music and fancy-dress themes that enable people to step outside their norms and explore fantasy roles (and actually thus internally explore their inner realms). Is this architecture? Probably not, though it organises people across space, with an emphasis on the power of expressive lighting to affect mood and alter behaviour. The parties centre on people – and rely on them; the people are the party. No matter how spectacular the act or DJ, a mass of 400 stunningly-clad, all interactively intertwining in concert like some giant human coral, is a stunning phenomenon – and remains a benchmark for architectural aspiration, to create architectural mechanisms that help people realise their inner potential – rather than simply comforting them with shelter and climate control and furniture.

We have found ourselves designing a lot of staircases (& I recall that even the fluid sonic-inspired landscapes of the DJagram had occasionally fractured into undulating Giant-Causeway-esque stepped landscapes). It can feel odd and paltry; a minor addendum to the architectural landscape; an energetic moment best kept in a box, beyond the sight of the calmer floorplates. But it also all too often feels like the only moment of pleasure left once all the rest of a project gets stripped out. No other architectural element receives so much attention, and becomes so articulated – a flattened floorplate suddenly intensified and folded and ruptured into a fractured landscape. No other element is quite so thoroughly 3-dimensional, defying flatness and planarity, piercing the ether.

Stairs are so fragrant with the whiff of the humans that use them; so resonant of the traces to come; such delicate armatures for weaving people through space. They offer the supreme opportunities for celebrating the few moments of human movement that architecture will allow. Most architectural movement happens outside buildings. Buildings encourage us to slow down; to sit and meet and work and read, or squat and shit, or lie and sleep. All major movements generally take place outside. Stairs are the last bastion of expressive human gesture; the arena for a pantheon of sporting activity (sitting, sliding, gently pacing, zig-zagging, climbing, skipping, racing, leaping); machines with which we test our ability to float our weight.

They confront us with gravity, and offer us the challenge to counteract it gracefully; to turn a constraint into an opportunity, and to blaze through time and space in a landscape that is otherwise silent and motionless.

Each step is a momentary point in an unfolding choreography – a word in an evolving sentence that the feet tap out, while the handrail pulls the body onwards in its trajectory, like the trial from a long-exposure, mapping the dancer’s move ever upwards.

Each stairway is like the male partner in a dance tango – a solid presence guiding its partner, enabling graceful movement. The phrase “it takes two to tango” suggests the interwoven mutual dependency of humanity and architecture; that they both need each other.

Stairs are also thrilling; challenging; dangerous. They might kill us. 2 of every million stair journeys ends in death. 1 in 2,000 prompts a stumble. They offer grace – and grave consequences; the appalling recognition that we might be our own ballistic weapon, carrying the force that crashes us through other matter to our death. They demand care and attention and precise movements. Our “Dreamscape” project for Sweden’s Arctic ICEHOTEL deployed perhaps the most unlikely of all building materials – which threatened serious injury if disrespected; we elevated the room’s only piece of furniture (the bed) to a midpoint in section which required curling stairs to access it, and made them from water – carving them from ice that was constantly melting and sublimating, ensuring the experience of finally reaching the refuge of bed was a huge reward.

When we first designed the “Sensualscaping” stairs for the Clapham House (unleashing our first use of CNC technology in order to afford the constructional complexity we couldn’t pay a contractor to create), people who’d never visited remarked upon their molten, plane-defying geometry (even though they’re effectively just a box of flatpack slices with clever, deceptive corner junctions), and expressed fear of falling – and what would happen if you were too drunk going down them. Yet the reality of their experience is far more fluid and graceful, their indented nosings cupping and embracing the body as if to gently massage the person upwards. Each step alters direction, continuously reorienting the visiting body, and engaging its legs in a kind of gentle conversation – rhythmically motivational, yet delicately renewed at each step.

Our “Roominaroom” project created a pocket, gem-like room in a room that cantilevered out to hover just above head-height, accessed by stairs that unfurled from a storage area and snapped to the window sills, establishing key datums that spiralled upwards until they led past a desk into a bed within a micro environment that mapped various possibilities for intersecting human occupation. Our “Headspace” project for Thornhill Primary School combined similar programming overlaps, deploying a radical grid that was cultural as well as purely geometrical: a decimal subdivision that mapped the Dewey Decimal system that underlay the categorical organisation of the library’s books. Shelves extended to become cantilevered steps that lead up to the mezzanine, and higher reaches of human knowledge, and form into seats and benches where one can nestle with books and rekindle the love of reading.

Our “Mobile Orchard” project created a mobile arboreal installation that had to be able to move and reconfigure around the City of London’s financial district, each week arriving at a new location. We arrayed the S-shaped branches in a subtle pattern that revealed (to some incredulity) a set of inner steps of sorts, which invited visitors to effortlessly start to walk up its angled trunk on a journey towards its crown, ushered upwards between the branches’ bifurcations.

When we designed “Meditations”, an incredibly fluid, fibrous steel stair for a superyacht, we were dismayed to learn that purely digital fabrication was actually going to be too inaccurate; that the helical bending we wanted to rely on (for bending our steel support tubes along constantly evolving radii) was not only eyewateringly expensive, but left far too large a tolerance – meaning all the delicate interconnections of pieces at tangential geometries were utterly impossible. It would have required a vast effort of human intervention just to correct each of the pieces, so all fabricators advised that it would actually be simpler to fabricate purely by hand. The stair’s eventual, simplified and deeply-rationalised design deployed steel bundles that each stacked a series of different radially-bent tubes, their tips connected together at pure tangents and welded smooth. I was



convinced that they'd at least build a vast CNC timber jig to help place all the elements and ensure a global fit, gradually removing modules as the steel structure emerged – but again they preferred to measure incrementally, by hand and laser. It wasn't as if there was room for error: our stair had to be cut into pieces, fed through a small slot in the boat, and installed with utmost precision in between a complex of expensive, intricately-sculpted wall panels, without touching or damaging them. And the fabricators succeeded; the hand won.

We turned to computers to make stuff out of desperation because we couldn't afford the humans (ironic, perhaps, given that all our designs seek to celebrate humans). Yet we typically can't afford the most expensive machines, and then have to resort to humans. Our most ambitious stair yet, "StairStalk", is currently under production in Poland, and though designed entirely parametrically, it'll be made entirely by hand, with hand-bent strips of laminated veneer lumber. The fabrication relies on computers for its foundation, and its core team is purely screen-based, but the project celebrates the fact that we still need humans to physically make things, and sometimes human intelligence is still at least more accessible and economic than AI. Sometimes, still, the ingenious hand knows more, and is best.

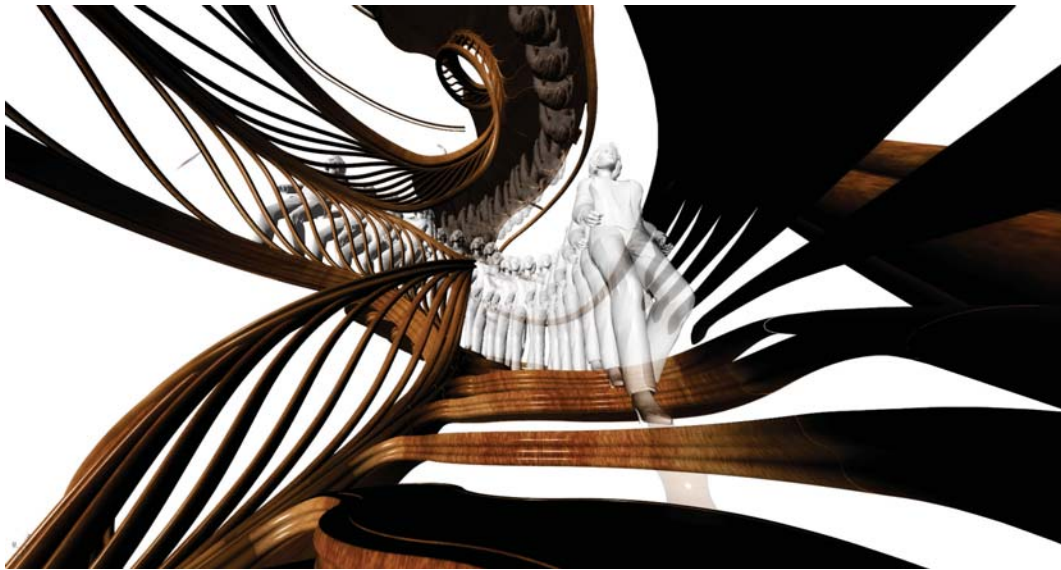

Figure 1. StairStalk





Figure 2. StairStalk

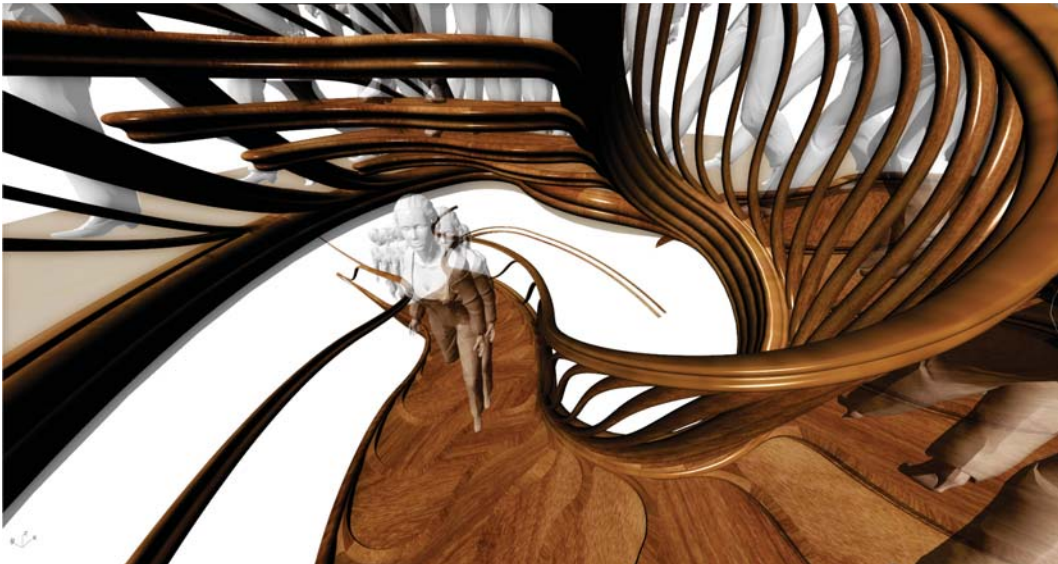

Figure 3. StairStalk



Figure 4. StairStalk



Figure 5. StairStalk



## Road Network Design with Space Syntax in Vendas Novas

Lázaro Ourique<sup>1</sup>, Carla Patrícia Dias<sup>2</sup>, Iolanda Fernandes<sup>3</sup>

<sup>1</sup>*Instituto Universitário de Lisboa (ISCTE-IUL), ISTAR-IUL, Lisbon, Portugal*, <sup>2</sup>*FESTO – Gabinete de Arquitectura, Planeamento e Consultadoria Imobiliária, Lda, Barreiro, Portugal*, <sup>3</sup>*Freelance Architect. Milan, Italy.*

<sup>1,2,3</sup> {lazarou.ourique/carlap.sdias/iolanda.piresfernandes}@gmail.com

**Abstract.** The city of Vendas Novas, Évora, Portugal, is crossed by a national road. Currently, 30.000 to 35.000 vehicles cross the city, of which more than 2.000 are heavy motor vehicles. Due to the negative effects of the high levels of traffic, the city council as long proposed an alternative route to Estrada Nacional 4.

To better understand the effects of an alternative route to the city of Vendas Novas our study applies an axial map analysis to the city current road network system and the two proposals currently being studied by the local city council and national infrastructure management entity. Based on this analysis a new proposal was drawn by our team to optimize the diversion of traffic from the city centre.

Through the application of an axial map analysis, in this study our team hoped to demonstrate and disseminate near the local city management entities the potential and validity of this tool to the current and future planning of cities and, in particular, road networks.

**Keywords.** *Space Syntax, Vehicular Traffic, Road Network*

### Introduction

Our team premise is that Space Syntax can be used, not only as an analysis tool of urban projects, but also to inform the design process of road networks due to its capacity to cheaply and quickly estimate vehicular traffic.

Space Syntax, in particular Axial Maps, is commonly used as a quantitative analysis tool, mainly to predict pedestrian use preferences and flows. Although research on traffic has been carried out, this use isn't yet a common practice. Though other tools are capable of yielding a more detailed simulation of vehicular traffic, e.g. SATURN, they demand a larger amount of preliminary data and highly detailed proposals. Additionally, these simulation systems aren't as comprehensive as Axial Maps or Angular Segment Analysis, which allows a broader understanding of the effects of a proposal on an urban area.

Our work follows Turner's (Turner, 2007) observations of the correlation between vehicular traffic and choice levels in angular segment analysis, in addition to previous work in pedestrian and cycling traffic.

We present a comparative analysis between three proposals for an A road alternative route in Vendas Novas, Portugal. For this process we utilized a conjugation of methods to analyze the various proposals that range from a traditional comparison of Space Syntax spatial measures to traffic estimations.

This work was accompanied by the Urban Management Department of the Municipality of Vendas Novas with various meetings to receive feedback throughout the process.

The remaining sections of this paper are structured as follows: Section 2 summarizes related work in the areas of Space Syntax and traffic prediction; Section 3 describes our experimental methodology; the current road network and the various proposals are presented in Section 4; in



Section 5, we discuss our results; and finally, we close the document with our conclusions and suggestions for future work.

## Related Work

Space Syntax theory introduced in 1976 by (Hillier et al., 1976) and his colleagues at University College of London brought forward a novel analytical and quantitative methodology to describe complex patterns of spatial organization capable of highlighting causal relationships between form and social patterns of use and occupation (Ourique, 2014).

Initial studies on Space Syntax indicated a high correlation between Integration and use of space (Dalton et al., 2010; Hillier et al., 1993; Penn et al., 1998; Serdoura, 2006; Turner, 2007). Since then research (Barros et al., 2007; Emo et al., 2012; Freeman et al., 1991; Kazerani and Winter, 2009; Kivimäki et al., 2016; Newman, 2005) have broaden the use of syntactic measures, showing that angular segment analysis and new measures yield higher correlations with pedestrian flows when compared with previously established methods.

In 2007, Turner developed a study indicating that Angular Segment Analysis, or ASA, in particular Choice, yield promising correlations levels to pedestrian flows. Jiang, in 2009, published a study comparing the correlation between various pedestrian and vehicular counts and multiple syntactic measures, further validating Space Syntax as a predictive tool for pedestrian and vehicular flows.

As of 2012, Hillier, Yang and Turner introduced the new measure Normalised Angular Choice, or NACH, to ASA. This new measure was introduced due to the rising need to use Choice on movement prediction in research and design. It provides a renewed understanding of cities, allowing not only for visual but also numerical comparison of various urban systems.

## Methodology

### *Axial Map Design and Analysis*

The work here presented used a base axial map (Figure 13) which considered all paved roads within a 10 kilometres radius from the urban limit of the city of Vendas Novas. Exceptionally, road segments beyond that limit were considered when a major intersection occurred within an extra 2 kilometres range.





Figure 1. Base Axial Map – ASA NACH r1000

This base axial map considered not only the city of Vendas Novas, but also 11 other surrounding villages.

Variations of this axial map were then created for each alternative route proposal. The original proposals – the PDM (Câmara Municipal de Vendas Novas, 1999) and the CM 2020 (Município de Vendas Novas, 2005) – didn't consider intersections of the pre-existing roads, which were introduced during our design process, mainly through the extension of the existing streets and avenues. The various axial maps were then converted into segment maps with the open-source software DepthmapX.

From DepthmapX we extracted several measures from the axial map analysis (ASA) –within radii N, 3 and 5 – and from de segment map –within radii N, 500, 1000 and 2000. Although we focused on ASA with NACH, due to their previously verified correlation with traffic counts, the Normalised Angular Integration, or NAIN, was also considered in addition to the more traditional AMA analysis with Integration, Depth, Connectivity and Choice.

### **Current Traffic Data**

For this project the team used the traffic data collected in 2005 by (Farias et al., 2007; Transitec, 2005). Even though the traffic data were collected in 2005, there's no new data currently available for the roads considered in our study (EN4, Misericórdia Avenue, 25 de Abril Avenue).

### **Traffic Estimation**

For the estimation of the traffic variation generated by the various proposals, our team used a Simple Linear Regression between the available traffic counts and NACH values of the corresponding street sections, achieving a moderate correlation of 0,6.

The original traffic counts were expressed in Equivalent Vehicle Unit/Day (UVE/d) where a large vehicle represents 2 UVE and all the other types of vehicle represent 1 UVE.

Previous work in this area used similar methodology for retrospective analysis, yielding correlation levels of 0,818 and higher (Hillier et al., 1993; Penn et al., 1998).



## Current Road Network and Proposals

The city of Vendas Novas is divided into four main sectors (Figure 14): the historical quartier established around the old Royal Palace, currently the Military School of Artillery; in the east, the Industrial Hub; in the north-east, a low density suburban residential area; and in the west, the newest urban expansion area that remains underdeveloped.

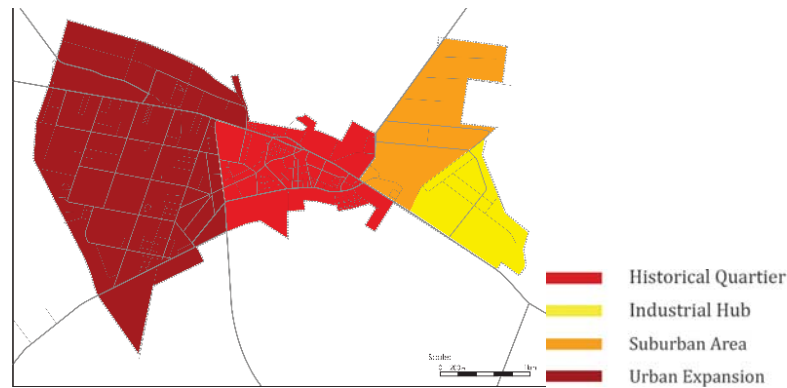

Figure 2. City sectors

## Current Road Network

The current road network of Vendas Novas (Figure 15) is, in its majority, constituted by small local streets and three main avenues: the EN4, Estrada Nacional 4 – Estrada do Alentejo Central, that crosses the city centre, from west to east; 25 de Abril Avenue that crosses the public service centre, from west to south-east; and Misericórdia Avenue which separates the historical quartier from the western urban expansion area.

The EN4 is an A Level Road that begins in the Metropolitan Area of Lisbon, in Montijo, crosses Central Alentejo, ending in the Portuguese-Spanish border in Elvas-Badajoz.

In Vendas Novas, the EN4 crosses the city centre, where the speed limit is reduced from 90km/h to 50km/h, with a 500m stretch where 30km/h speed limit is implemented. Additionally, the EN4 cuts through the main commercial area of the city, separating the main city plaza from the shopping promenade. With the increase of traffic flow, the promenade was redesigned with a high density green barrier to mitigate the negative effects caused by the road.

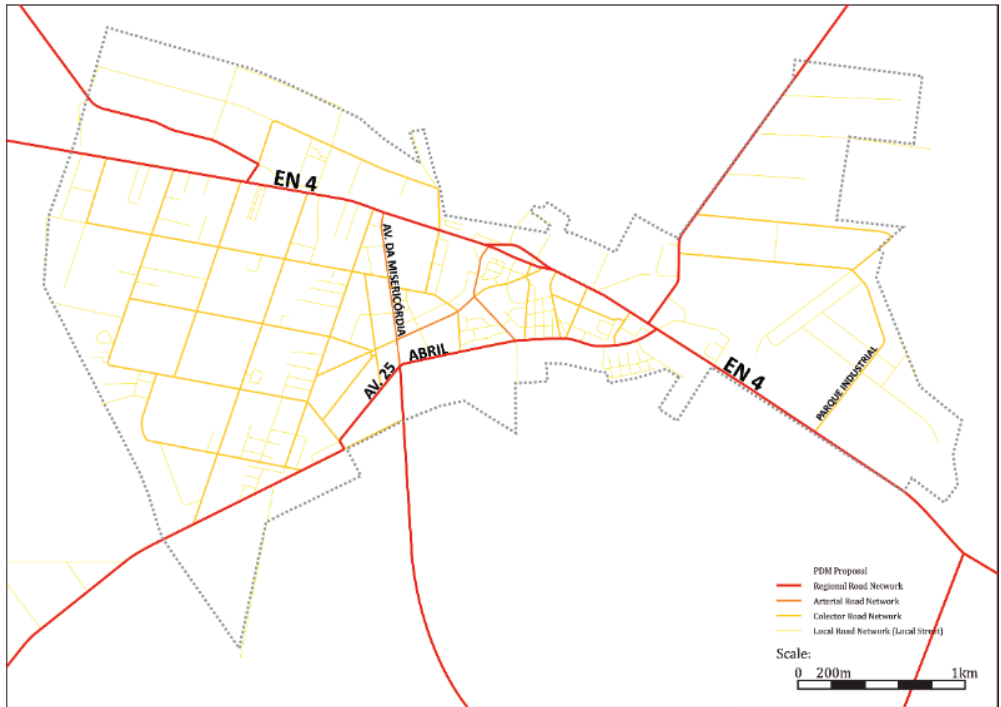

Figure 3. Current Road Network

### PDM Proposal

In 1999, the Municipality of Vendas Novas published the current City Plan (Câmara Municipal de Vendas Novas, 1999) (Figure 16) that introduced the western expansion zone and proposed an EN4 alternative route. This design consolidated the southern urban limit of the city and tried to divert as much traffic as possible from the city centre.



Figure 4. PDM Proposal

### CM 2020 Proposal

In 2005, the Municipality created a new Strategic Plan for the City (Município de Vendas Novas, 2005) where it redesigned the original proposal for the EN4 alternative route (Figure 17), expanding it to include the village of Bombel, 3km west from the city limits, allocating this area as

a new urban expansion zone. This plan wasn't well received by the population resulting in an amendment that removed the proposed urban expansion zone but kept the new road design.

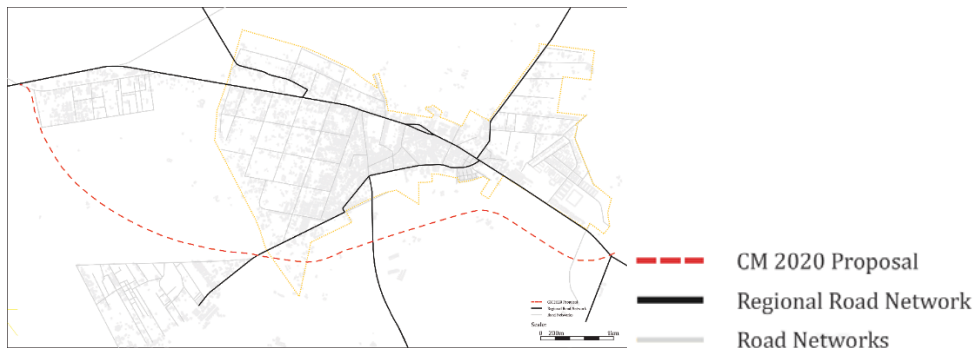

Figure 5. CM 2020 Proposal

### Team Proposal

Our team proposal (Figure 18) considered the results of the previous designs and created a circular road that encloses the current city and planned expansions areas.



Figure 6. Team Proposal

The design process was incremental, recurring to Space Syntax to optimize the traffic diversion and the general benefits to the city as a whole. That was achieved by increasing local measures' results in the pre-existing road network and global measures in the proposed circular road.

## Results and Discussion

### Space Syntax analysis of road proposals

The Axial Map and Angular Segment Analysis revealed that the C.M. 2020 proposal has the weakest ability to divert traffic. It has the lowest results across all measures, especially in NACH r1000 (Table 1) where it is 47,13% lower than all the other proposals.



	Global	r500	r1000	r2000
PDM	5,310	1,197	2,141	3,215
CM2020	4,813	0,644	1,132	1,997
TEAM	5,944	1,111	2,187	3,326

Table 1. Values of Global, r500, r1000 and r2000 NACH for each proposal

It is our understanding that this discrepancy is due to the original proposal containing an extension to the west urban expansion zone that was later removed.

Comparing the other two proposals, both are well balanced. The Team proposal attains a lower NACH R500 and slightly higher values in NACH Global, R1000 and R2000 than the PDM proposal, characteristics that are in line with the main purpose of the new route.

In the remaining syntactic measures – NAIN, Axial Integration, Depth, Connectivity and Choice – no major difference was observed between the PDM and Team proposal.

### Effects of the proposed road on the current road network

By analysing the various measures, we verified that the C.M. 2020 proposal does not meet its intended goal, the diversion of traffic from EN4. Visually no major effects are registered on the system, while quantitatively the only major effects are registered in 25 de Abril Avenue, with an estimated 41% decrease of traffic, and in Misericórdia Avenue, with an estimated 44% increase of traffic (Table 2).

	Current	PDM	CM2020	Team
EN4	13000 UVE/D	- 18%	- 10%	- 33%
25 de Abril Avenue	9000 UVE/D	- 41%	- 30%	- 66%
Misericórdia Avenue	5000 UVE/D	+ 44%	+ 54%	+ 53%

Table 2. Current Traffic Count (UVE/D) and estimated variation for the 3 main roads in the city

The PDM proposal registered an 18% decrease of traffic in EN4, in addition to a small increase across Axial measures on the Historical quartier. This indicates a potential lowering of non-stop traffic in the EN4 and no major influence in other types of traffic.

On the Team proposal, there are major variations in all measures. Visually, comparing the Axial measures, we recorded a large increase of values on the historical *quartier*, indicating a consolidation of this area as the city centre.

By analysing the estimated traffic variation, we concluded that our team proposal effectively diverts traffic from the EN4 with an estimated traffic decrease of 33%. Additionally, we registered a significant increase of traffic in *Misericórdia Avenue*, possibly indicating the potential transformation of this road into the main traffic distributor of the city.

### Proposed routes traffic predictive analysis

By comparing the traffic estimation of the various proposals, Table 3 allows us to verify that between all of them, the C.M. 2020 has the lowest ability to divert traffic from the city, with only 1220 UVE/D utilizing the new route.



	PDM	CM2020	Team
Proposed routes	5422 UVE/D	1220 UVE/D	10798 UVE/D

*Table 3. Traffic Estimations for Each Proposal*

The PDM proposal, though achieving significant levels of estimated traffic (5422 UVE/D), did not achieve the levels desired by the Municipal Council – 6500 UVE/D or half the current EN4 traffic.

On the other hand, our team proposal attracted almost 11000 UVE/D, not only exceeding the minimal traffic volume requested by 66%, but also establishing the proposed route as a clear alternative to the EN4.

Considering the data presented in the previous sections, the team believes that our design generates a good alternative route to EN4 not only in a national level, but also for regional traffic.

## Conclusions and Future Work

Throughout this project, the use of Space Syntax as a rapid analysis tool to refine a project proposal was essential. It allowed our team not only to adjust the outline of its proposal, but also to understand the effects that the various modifications had on the road network at a city-wide scale. This gave us the opportunity to steer the proposal towards a regional distributor, in addition to a national alternative to EN4.

We consider that traffic prediction capabilities of Space Syntax need refinement but revealed to be significant in this preliminary design stage. Although our team is confident in the results obtained, none of the proposals had, at the time of this analysis, detailed intersection or cross-section design which could ultimately create specific traffic dynamics that Space Syntax overlooks, generating the need for a full-fledged traffic simulation.

The project was well received by the Municipality, even though it met some resistance in the beginning of the process, probably due to the unfamiliarity with Space Syntax. This leads us to believe that there is a clear need to disseminate Space Syntax to key Portuguese stakeholders in urban planning.

Finally, we believe that additional work is needed to understand where the introduction of other traffic flow simulation tools is optimal in the design process of road networks and to guarantee the validity of the Normalised Angular Choice as a vehicular predictive measure.

## Acknowledgements

We are grateful for the review and comments of our dear colleague Inês Lory Pereira.

## References

Barros, A., Silva, P., Holanda, F., 2007. Exploratory Study of Space Syntax as a Traffic Assignment Tool, in: Proceedings, 6th International Space Syntax Symposium. Presented at the 6th International Space Syntax Symposium, Istanbul Technical University, Istanbul, Turkey, pp. 79-1-14.

Câmara Municipal de Vendas Novas, 1999. Regulamento do Plano Director Municipal de Vendas Novas. Município de Vendas Novas, Lisbon, Portugal.

- Dalton, R., Hoelscher, C., Peck, T., Pawar, V., 2010. Judgments of building complexity & navigability in virtual reality, in: *Spatial Cognition VII*. Presented at the Spatial Cognition 2010, Portland, Oregon, USA.
- Emo, B., Hölscher, C., Wiener, J., Dalton, R., 2012. Wayfinding and Spatial Configuration: evidence from street corners, in: *Proceedings: Eighth International Space Syntax Symposium*. Presented at the 8th International Space Syntax Symposium, Pontificia Universidad Católica de Chile, Santiago de Chile, Chile, p. 8098:1-8098:16.
- Farias, T., Vasconcelos, A., Taborda, S., Tiago, C., 2007. Plano de Mobilidade Sustentável de Vendas Novas - Relatório de Diagnóstico. Instituto Superior Técnico, DTEA - Transportes, Energia e Ambiente.
- Freeman, L., Borgatti, S., White, D., 1991. Centrality in valued graphs: A measure of betweenness based on network flow. *Soc. Netw.* 13, 141–154.
- Hillier, B., Leaman, A., Stansall, P., Bedford, M., 1976. Space Syntax. *Environ. Plan. B Plan. Des.* 3, 147–185.
- Hillier, B., Penn, A., Grajewski, T., Xu, J., 1993. Natural Movement: or, configuration and attraction in urban pedestrian movement. *Environ. Plan. B Plan. Des.* 20, 29–66.
- Hillier, B., Yang, T., Turner, A., 2012. Normalising least angle choice in Depthmap and how it opens up a new perspective on the global and local analysis of city space. *J. Space Syntax* 3, 155–193pp.
- Jiang, B., 2009. Ranking Spaces for Predicting Human Movement in an Urban Environment. *Int. J. Geogr. Inf. Sci.* 23, 823–837. doi:10.1080/13658810802022822
- Kazerani, A., Winter, S., 2009. Can Betweenness Centrality Explain Traffic Flow?, in: *Proceedings 12th AGILE International Conference on Geographic Information Science*. Presented at the 12th AGILE International Conference on Geographic Information Science, Leibniz Universität Hannover, Germany, Hannover, Germany.
- Kivimäki, I., Leicht, B., Saramäki, J., Saerens, M., 2016. Two betweenness centrality measures based on Randomized Shortest Paths. *Sci. Rep.* 6. doi:10.1038
- Município de Vendas Novas, 2005. Vendas Novas 2020: Construir a Sustentabilidade de uma Localização Privilegiada – Uma Estratégia para 2020; Um Plano de Acção para 2007-2013. Município de Vendas Novas, Vendas Novas.
- Newman, M.E.J., 2005. A measure of betweenness centrality based on random walks. *Soc. Netw.* 27, 39–54.
- Ourique, L., 2014. Por uma Nova Urbanidade - Vendas Novas, Regeneração e Reintegração do Pólo Industrial (Masters). Universidade de Lisboa - Faculdade de Arquitectura, Lisbon, Portugal.
- Penn, A., Hillier, B., Banister, D., Xu, J., 1998. Configurational modelling of urban movement networks. *Environ. Plan. B Plan. Des.* 25, 59–84. doi:10.1068/b250059
- Serdoura, F., 2006. Espaço Público, Vida Pública – O Caso do Parque das Nações (PhD). Universidade Técnica de Lisboa - Instituto Superior Técnico, Lisbon, Portugal.
- Transitec, 2005. Estudo de circulação e estacionamento na cidade de Vendas Novas, Transitec. Transitec, Lisbon, Portugal.
- Turner, A., 2007. From Axial to Road-Centre Lines: a New Representation for Space Syntax and a New Model of Route Choice for Transport Network Analysis. *Environ. Plan. B - Plan. Des.* 34, 539–555. doi:10.1068/b32067.





## Extreme Cold Conditions Architecture

### An Antarctica's shelter prototype

Diogo Bulhões<sup>1</sup>, Vasco Rato<sup>2</sup>, Manuel C. Guedes<sup>3</sup>

<sup>1,2</sup>Instituto Universitário de Lisboa (ISCTE-IUL), Portugal. <sup>3</sup>Instituto Superior Técnico – UL, Portugal.

<sup>1</sup> diogobulhoes13@gmail.com

**Abstract.** Nowadays, when performing expeditions to the most remote places in Antarctica, scientists typically use tents as shelters. These tents, albeit being very portable and easy to assemble, lack the structural stability to withstand the harsh conditions of the Antarctic environment. Therefore, this paper pursues to conceive a novel shelter prototype that, more adequately, protects and lodges the researchers in their scientific missions in this icy continent, all the while maintaining a focus on portability and sustainability. In a first stage, some facts about the Antarctic continent are presented, likewise its significance to Science and our species. Secondly, a mobile base, inspired by a yurt, conceived within the framework of POLAR LODGE (a subproject of the Portuguese Polar Program), is analysed. The paper then focuses on a brief review on aerodynamics, seeking to comprehend the interaction of shapes and air flow, so that the design performance requirements related to strong winds are better understood. Finally, in a second stage, based on the previous researches, two different paradigms of a portable base are exposed and the final prototype is conceived and presented alongside a brief discussion of its constitution, assembly methods, materials and techniques.

**Keywords.** Aerodynamic; Antarctica; Detachable-Structure; Module; Sustainability.

## Introduction

Nowadays, when performing expeditions to the most remote places in Antarctica, scientists typically use tents as shelters. These tents, albeit being very portable and easy to assemble, lack the structural stability to withstand the harsh conditions of the Antarctic environment, namely very strong and unpredictable winds.

This paper seeks to contribute to find solutions for the lodging of researchers in their cold environment expeditions, particularly in the Antarctica continent, by developing a sustainable, wind-resistant and detachable module. This novel module finds inspirations in the project POLAR LODGE [4] and in a brief review of the basic principles of aerodynamics. The work was accomplished by means of 3D modelling.

The work is divided in five main topics. The first topic presents a brief summary about the main characteristics and importance of Antarctica continent. Secondly, the POLAR LODGE project is introduced; this project produced and installed in Antarctica a lodging module inspired in the Mongol nomad lodge - the yurt. The third topic is a brief review on the basics principles of aerodynamics; this was motivated by the POLAR LODGE project reported experience on the difficulties to withstand the very hard Antarctica's wind conditions and the need to search for a

streamlined shape. The fourth topic presents two different paradigms for a novel model. Finally the fifth topic introduces the final novel module, detailing its morphology, materials and structure.

## Antarctica

The name Antarctica originates from the opposition to the Arctic [6].

Antarctica is the southernmost continent on our planet and almost its entire surface is covered by ice. Due to its location, this region is one of the most extreme places on Earth. The average temperature in the inner region of the continent varies between  $-40^{\circ}\text{C}$  to  $-70^{\circ}\text{C}$  in Winter and  $-20^{\circ}\text{C}$  to  $-35^{\circ}\text{C}$  in Summer. In regards to the Antarctica's costal edge the temperature varies between  $-20^{\circ}\text{C}$  to  $-30^{\circ}\text{C}$  and  $0^{\circ}\text{C}$  respectively. Wind is a constant in the icy continent and wind conditions are often. The wind is harsh and unpredictable [6].

The continent has an extreme importance for Science, albeit the harsh conditions. In this icy place, the researchers can study the past changes in Earth's climate by extracting ice cores from the ice sheets [7]. Antarctica has also a great significance in an astronomic level. This region, especially the lakes beneath the glaciers, emulates the Jupiter and Saturn's moons features. Similarly, the dry and cold atmosphere creates some of the best conditions in our planet for observing the space [8].

In what regards our planet, Antarctica has also an important feature of regulating the Earth's climate, namely the temperature, humidity, atmospheric pressure and wind patterns due to the Antarctic Circumpolar Current [9].

The Antarctica continent incorporates a vast spectrum of minerals and resources, such as coal, gold, iron, lead, uranium and zinc [6]. Nevertheless, in what concerns human interests in near future, water might be the main resource incorporated in Antarctica. 75 % of the planet's fresh water is stored in glaciers ice [10]. Antarctica continent embodies 90 % of the total glacier ice [6], representing approximately 70 % of all the fresh water in our planet.

Even though being a pristine region, this continent suffers as well from the human impact especially from the global warming. This impact is expressed by the ice shelf collapsing and defrosting [11].

## Yurt Project, POLAR LODGE

This project, within the framework of POLAR LODGE (a subproject of the Portuguese Polar Program) developed a mobile, resistant and comfortable module to lodge scientists in their expeditions to the most remote places in Antarctica. The motivation for such a module lies on the fact that, nowadays, researchers use tents for lodging [12]. These tents albeit being very portable and easy to assemble, lack the structural stability to withstand the harsh conditions of the Antarctic environment.

The prototype was inspired by the design and features of the Mongol tent - the yurt. A significant part of the module's materials is biodegradable. It consists of a base and a frame structure made with wood (chestnut), covered by wool layers, and protected by a PVC fabric, due to its impermeable features [12].

In what concerns thermal comfort conditions, the measured temperature difference between the external environment and the interior of the module was  $6^{\circ}\text{C}$  and  $8^{\circ}\text{C}$  when installed in Collins Glassier. These were considered as excellent conditions within the scope of a portable structure [12].

The module was capable to withstand winds of 100 to 120 km/h, which was considered average wind speeds for that region. However, due to the climate change conditions, extreme wind phenomena are now more frequent. By the end of the summer 2016, 200 km/h winds were registered. The prototype's resistance to wind load was not enough and the module was

dismantled. On the other hand, the use of tents will be more and more impossible due to these winds [12].

Consequently, there is a need to develop a novel prototype with the ability to resist to high wind loads. Considering that these types of portable modules may not depend on high-strength foundations nor concrete heavy structures; the module's geometry must consider the basic principles of aerodynamics together with the prevailing wind direction.

## Basic principles of aerodynamics

The objective of minimizing the consequences of high wind loads in the new architectural module requires the comprehension of how shapes interact with air flow. Therefore, a brief review on aerodynamics was carried out.

In this contest, the main feature in aerodynamics is the drag force which has an opposite direction from that of the movement of the object [13]. Aerodynamics engineering uses the drag coefficient to represent how different shapes interact with the air flow and to design streamlined geometries. The lower the drag coefficient, the more streamlined is the form. The drag coefficient is usually determined experimentally and is related to the drag equation:

$$D = C_d \cdot \frac{\rho \cdot V^2}{2} \cdot A \quad (\text{eq. 1})$$

where,

D: Drag [N];

C<sub>d</sub>: Drag coefficient [-];

ρ: Air density [kg/m<sup>3</sup>];

V: Wind speed [m/s];

A: frontal area [m<sup>2</sup>].

The least drag coefficient is obtained with an airfoil section geometry (fig 1), which means that this is the shape that assures the minimum wind drag.

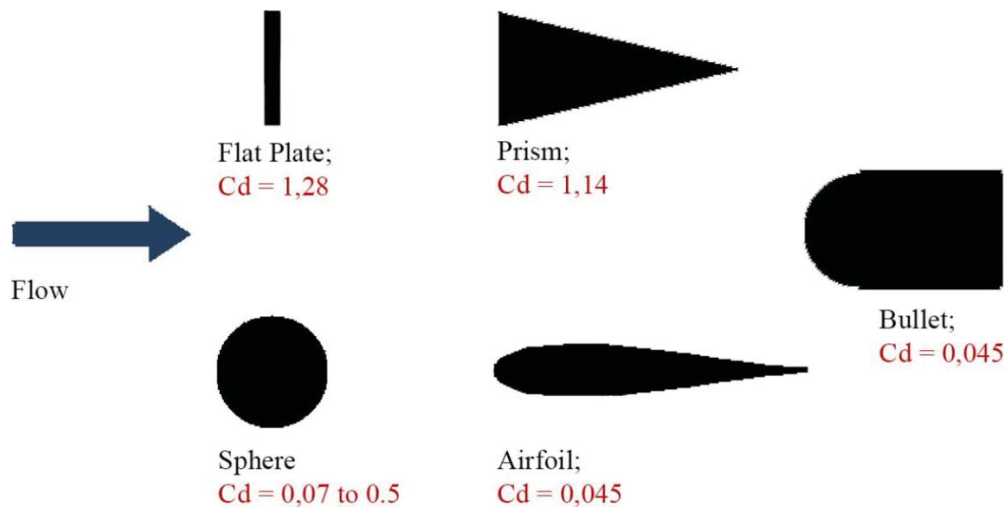

Figure 1. Drag coefficient values according to different shapes. All objects have the same frontal area. Based on: [8].

In this kind of shape (airfoil section or streamlined body or even a teardrop form) the drag force is caused by the skin friction and flow pressure. This geometry provides a gradual pressure gradient over the body [1]. This geometry also offers a delay in the separation flow (that comes from the interaction of the object and the flow) resulting in a minimum pressure drag [14]. This also decreases the turbulence in the trailing edge [3].

## Different paradigms

During the development of the novel model two different paradigms of prototypes were envisaged.

The first exemplar was inspired by the Sogn Benedetg chapel's geometry, designed by the Swiss architect Peter Zumthor, inaugurated in 1988 [5]. The yurt's wooden grid structure is also added to the prototype. This geometry has similarities with the airfoil design (fig. 2).

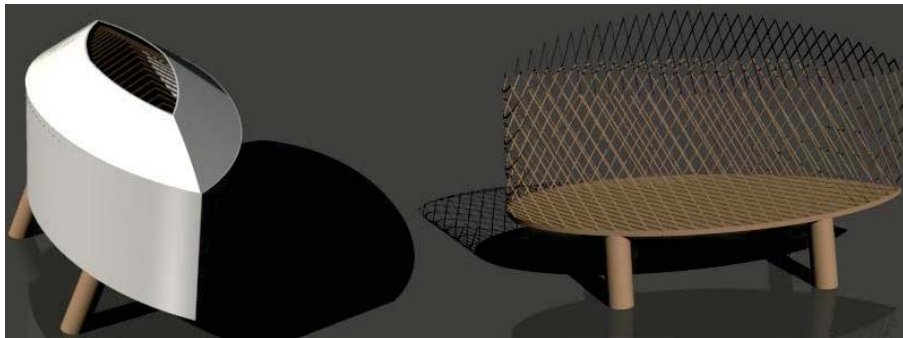

Figure 2. 3D modulation: Prototype and its grid structure similar to the yurt.

The second prototype was inspired by the musical instrument accordion. As well as the musical instrument, this prototype is capable to reduce its dimension by overlapping its parts (fig. 3). This feature is appropriate for an easy transportation. The module's structure consists in nine arches made with recycled material branded CORETECH. The structure is involved by mineral wool layers for thermal insulation, and it is cladded by biodegradable PVC fabric for waterproofing (fig. 4).

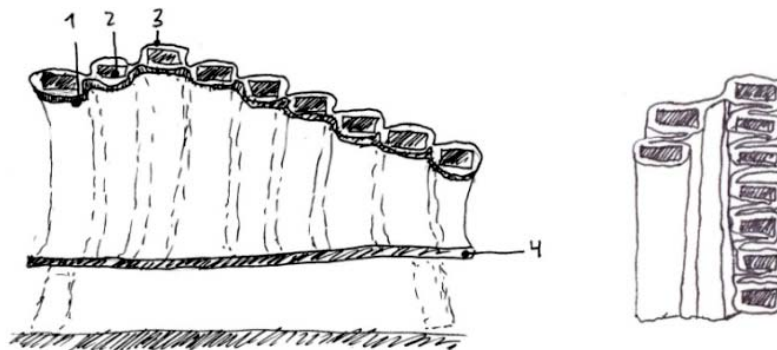

Figure 3. Right draw: Transversal section. 1- Wool layer. 2- Structure. 3- Biodegradable PVC fabric. 4- Base; Left draw: The structure's overlapping mode as the musical instrument.

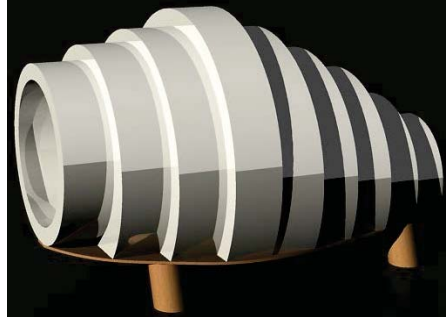

Figure 4. 3D modulation: Accordion inspired prototype.

## The novel module

### *Constitution and materials*

Four main premises formed the basis for material selection: Transportation, extreme cold, environmental impact and wind load. The difficulties in transportation arise from the fact that the final stage of the trip to Antarctica is assured by a small semi-rigid boat with a maximum load capacity of 2000 kg.

The selected materials are mineral wool, biodegradable PVC fabric, aluminum and a recycled material branded *CORETECH*. The mineral wool is the inner most material, assuring thermal insulation and complying with the need of flexibility and low weight. The biodegradable PVC fabric, used for the middle layer, is flexible, light and waterproof [15]. These materials, namely the wool and the PVC fabric were already tested in the POLAR LODGE project [4].

The aluminum is used as the outer layer protective shell. It is a light (only about a third of iron and steel's weight), ductile and easy to mold material that ensures the appropriate superficial strength to wind loads and does not become fragile nor it corrodes due to its permanent protective layer. Furthermore, the recyclability of aluminum and its abundancy (the third most common element in Earth) [2] makes it an appropriate choice from the sustainability standpoint.

Finally, *CORETECH* was chosen as structural material. This is a recycled material, composed by grinded automobile sub products. It is waterproof, has high durability and good compressive and tensile strength within the scope of this application [16].

### *Design and Structure*

The design process for the definition of the novel module's geometry considered the brief aerodynamic study, described above. To minimize the high wind loads, the form's design has been inspired by the airfoil section or the teardrop shape, to become a streamlined body. Besides shape, the module's final geometry also considered the minimum dimensions suitable for four researchers.

To comply with the needs for easy disassemble, low weight and strength, a "waffle-like" structure was envisaged. It is defined by four longitudinal and seven transversal arches. Each type of arch is assembled concurrently to the other. Both types of arches have a maximum height ( $h$ ) of 3 m. The larger axis has a dimension of 3.26 m and 6.32 m respectively in the transversal and longitudinal directions (fig. 5; line segments,  $aa'$  and  $bb'$ ). The prototype's base is also made with the same material as the structure. The entire module will be elevated preventing the permafrost humidity.



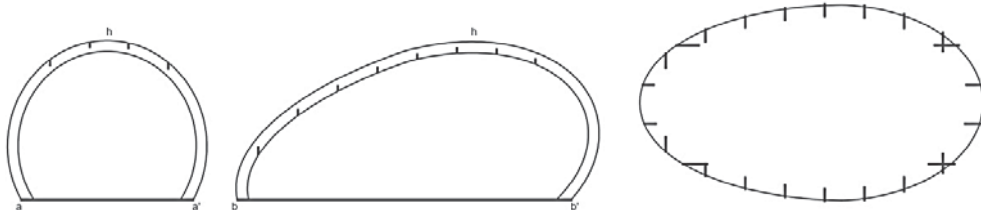

Figure 5. Structural plan: Transversal arch (left); longitudinal arch (centre); floorplan (right).

Figure 6 shows the assembled structural elements. Figure 7 illustrates the set of filling and cladding materials. The structure is involved by mineral wool layers for thermal insulation, the biodegradable PVC fabric for waterproofing and the aluminum "shell" for resistance to wandering and wind loads. The aluminum shell is divided in four sheets.

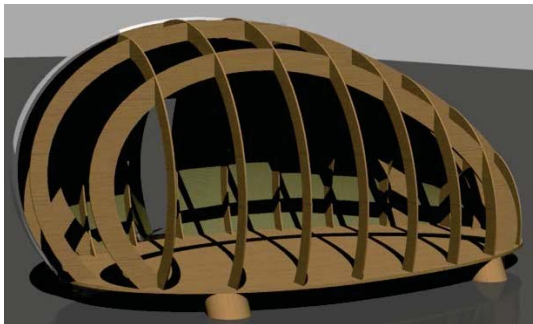

Figure 6. Final module's 3D modulation: Structural set



Figure 7. Final module's 3D modulation: Extruded aluminium plaques

The total weight of the module was estimated with the quantity of material used and the respective density. Unit and calculated values are showed in table 1

Total structural volume	m <sup>3</sup>	0,7746
Material density	Kg/m <sup>3</sup>	650
Total structural weight	Kg	503,09

Table 1. Unit values of the structural elements

Considering a CORETECH material density of 650 kg/m<sup>3</sup> the structural elements and the horizontal base have a total weight of 503,09 kg.

The drag (*D*) value of the prototype was also calculated according to equation 1 with the geometry's drag coefficient (*C<sub>d</sub>*) [13], the air density (*ρ*) at -2 °C (average temperature in Bellingshausen), the wind speed (*V*) (maximum speed registered by the end of Summer 2016) and the module's frontal area (*A*). Units and calculated value are showed in table 2.

Drag coefficient ( $C_d$ )	-	0.09
Air density ( $\rho$ )	kg/m <sup>3</sup>	1,302
Wind seed ( $V$ )	m/s	55,6
Frontal area ( $A$ )	m <sup>2</sup>	20,7
Total drag ( $D$ )	N	3749,2

Table 2. Unit values to calculate the module's drag with eq. 1.

The module has a total drag of 3,7 kN or 0,18 kN/m<sup>2</sup>. For comparison, in what regards a common building wind loads, the Portuguese safety value is 1,2 kN/m<sup>2</sup> or less.

### Interior

Due to the streamlined body design, the internal volume has two different areas: a wider space between the wind-facing side and the middle of the floorplan and a narrowed space in the opposite side. The first is intended as a working space, while the latter as a resting and sleeping area. Total floor area is 16 m<sup>2</sup>. A skylight, inspired by the Mongol's yurt, illuminates the module's interior (fig. 8 and fig 9), protected by a transparent biodegradable PVC fabric. The wool can be seen through the interior to conceive a cozy environment (fig. 9).

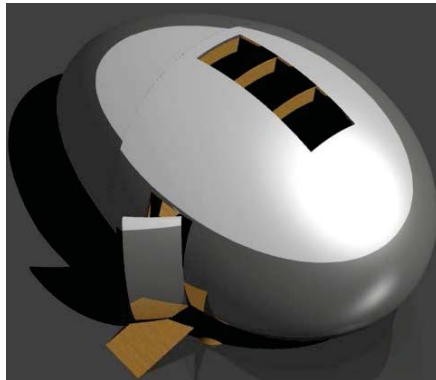

Figure 8. Final module's 3D modulation: Skylight from the exterior.



Figure 9. Final module's 3D modulation: The wool walls, the structure and the light from the skylight.

### Orientation

The geometry that was defined is based on the need to minimize wind load on the surface of the module. However, this geometry is flow direction-sensitive; to minimize the wind drag, facing the module against the prevailing wind flow is crucial. Therefore, the prevailing wind direction must be ascertained. This task was carried out by analyzing local climatic data with the use of Autodesk Ecotect Analysis 2011. The climate file for Bellingshausen (-62,5; -58,9<sup>o</sup>) was used. It may be noted that there is a prevailing West-East direction (fig. 10).

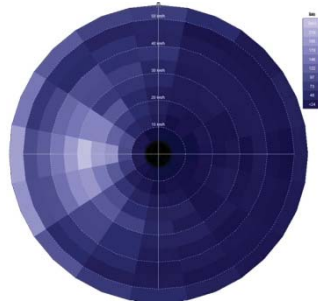

Figure 10. Dominant winds in Bellingshausen, (-62,5; -58,9°). Wind frequency (Hrs) 1st January – 31st December. 00:00-24:00h.

### Territorial insertion

The aluminum moreover gives a reflective surface. The novel module can be comfortable and resistant all the while maintaining less physical impact upon this fragile territory, shown in the figure 11. The withdrawal's prototype could be prevented too, due to the detachable module's feature.

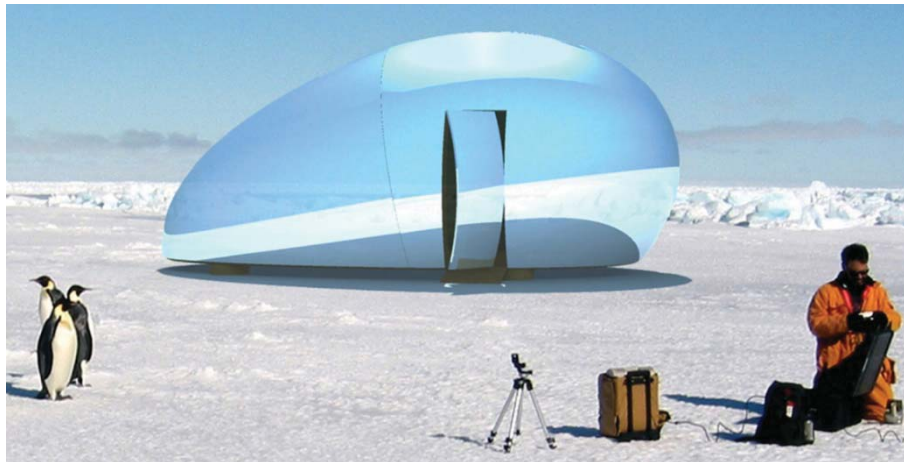

Figure 11. Final module's 3D modulation: Prototype's territorial insertion. Background photography: Ted Scambos, NSIDC.

"The future depends on what you do today" (Mahatma Gandhi, 1869-1948)

## Conclusions

Among all the unique challenges involved in the development of a novel mobile module for researchers to explore and unravel the features of Antarctica, four have been identified as being crucial to the success of the project: sustainability, transportation, geometry, and structural integrity.

During the development of the module described in this paper, the PROPOLAR project proved to be a valuable case study as it had conducted on-site testing of materials, structures and inner spatiality. This led to several vital insights such as the recognition that simpler and more sustainable materials often prove to be as good as more engineered ones (as is the case with wool in relation to thermal comfort). Furthermore, it alerted us to the importance of aerodynamics in the design of a module's geometry to ensure structural integrity even in the presence of very strong winds.



Due to the icy continent's harsh and inhospitable conditions, it has remained relatively untouched by direct human contact. Therefore, any project of this kind must attempt to limit as much as possible its impact on the surrounding environment. So, in regards to the materials used in the module, an attempt was made to focus on simpler and less environmentally-impacting materials. As such, wool was chosen for the inner layer of the module due to its excellent thermal comfort, comparable to that provided by more engineered and less sustainable materials. Moreover, waterproof capabilities were achieved with biodegradable PVC fabric and aluminum was used for the outer layer protective shell due to its lightness, durability, ductility and abundance. To comply with the needs of easy disassemble, low-weight and structural strength, a "waffle-like" structure made with a recycle material branded *CORETECH*, was envisaged with a total weight of 466 kg. This recycle and waterproof material has high durability, good compressive and tensile strength.

The structure and the modules were developed by means of 3D modelling.

As future work, firstly, a 1:5 prototype of the module described in this paper will be constructed and subject to tests in a wind tunnel to tune the geometry. Secondly, a real-scale prototype will be built to analyse and improve assembly logic. Finally, a third improved prototype will be sent to Antarctica to be tested under real conditions.

"(...) it has the right meaning which respects the ecological values of Antarctica, the shearing and an environmental respect." [12]

## References

- [1] Bertin, J. J. and Michaels, S. L., 1979. *Aerodynamics for Engineers*. Englewood Cliffs(New Jersey): Prentice-Hall, Inc.
- [2] Hegger, M., Auch-Schwilk, V., Funchs, M. and Rosenkranz, T., 2006. *Construction Materials Manual*. Munich: Institut für internationale Architektur-Dokumentation GmbH & Co. KG.
- [3] Houghton, E. L. & Carpenter, P. W., 1993. *Aerodynamics for Engineering Students*. 4<sup>th</sup> ed. Oxford: Butterworth-Heinemann.
- [4] POLAR LODGE, 2016. A Sustainable Modular Building for Research Development in the Antarctic. Lisbon, s.n., p. 63.
- [5] Zumthor, P., 2014. *Peter Zumthor 1985-1989, Buildings and Projects*. Zurich: Verlag Scheidegger & Spiess AG.
- [6] <https://www.britannica.com/place/Antarctica>
- [7] <https://nsidc.org/cryosphere/quickfacts/icesheets.html>
- [8] <http://www.nature.com/news/polar-research-six-priorities-for-antarctic-science-1.15658#/ref-link-2>
- [9] <http://www.environment.gov.au/science/soe/2011-report/7-antarctic/1-introduction/1-1-global-importance>
- [10] <https://nsidc.org/cryosphere/glaciers/quickfacts.html>
- [11] [http://www.coolantarctica.com/Antarctica%20fact%20file/science/human\\_impact\\_on\\_antarctica.php](http://www.coolantarctica.com/Antarctica%20fact%20file/science/human_impact_on_antarctica.php)
- [12] [https://tecnico.ulisboa.pt/pt/noticias/2016/2/Projeto\\_pioneiro\\_do\\_Tecnico\\_na\\_Antartida](https://tecnico.ulisboa.pt/pt/noticias/2016/2/Projeto_pioneiro_do_Tecnico_na_Antartida)
- [13] <https://spaceflightsystems.grc.nasa.gov/education/rocket/shaped.html>
- [14] <http://www.aerospaceweb.org/question/aerodynamics/q0215.shtml>



- [15] <http://www.goecopure.com/how-ecopure-biodegrades-plastic-products-in-landfills.aspx>
- [16] [http://www.coretech.pt/cms.php?id\\_cms=2](http://www.coretech.pt/cms.php?id_cms=2)



## Architectural Bionics: From Living Nature to Architecture

Dmitri Kozlov

*Research Institute of Theory and History of Architecture and Urban Planning, Russia.*

*kozlov.dmitri@gmail.com*

**Abstract.** Nature-based architectural design as a new trend in design-science emerged worldwide in the early 1960s. In the Soviet Union it was known as “architectural bionics”. Its deep researches of natural form-generative principles have led to a new vision of formative processes and technical means in architecture and to a system of innovative solutions in building. This paper is dedicated to the history of architectural bionics, its main theoretical and practical achievements and their possible applications in contemporary architectural design-science, practice and education.

**Keywords.** *architectural bionics; form-generation; resilient structures; history of architecture.*

### Origin of Architectural Bionics

Architectural bionics originated in the USSR as a new theoretical and practical trend in architecture in the middle of 1960s. Today this priority is internationally recognized. Thus, the Austrian researcher of bionics in architecture Petra Gruber writes: “The Russian Juri S. Lebedev in the 1960s wrote the only comprehensive work done so far on ‘Architekturbionik’” (Gruber, 2011).

The term “architectural bionics” was introduced in 1966 by Russian architect and researcher Yuri Sergeyeovich Lebedev (1921–1992). His early studies in this field started in 1958 and were summarized in his first paper written in co-authorship with architect V. V. Zefeld (Lebedev, Zefeld, 1962). Their paper was dedicated to comparison of building structures in architecture with structural organization of plants, though the term “bionics” was not mentioned in it. It is not surprising that architects in the early 1960s were not familiar with this term: it was invented by the US scientist Jack E. Steele only in 1958. Nevertheless the paper by Lebedev and Zefeld was a bionic one in its essence: the authors analyzed functional analogies between building and vegetation structures. They considered outward forms of the both kinds of structures as results of interaction between the gravitation and the forces of growth and development.

This early publication completely belongs to the trend that is now known as “*building bionics*” or “*biomimetics*”. It deals with analogical application of natural structures and processes as well as evolutionary principles of animate nature to problem solving in the fields of technics and engineering sciences in architecture (Pohl, Nachtigall, 2015). As opposed to building bionics the architectural bionics includes engineering bionics only as one of its components along with aesthetic and artistic similarities between animate nature and architecture.

Main principles of architectural bionics were formulated by Yuri S. Lebedev in the period of 1962–1968 and were taken as a basis in his Ph.D. thesis of 1969 titled “*Architecture and Bionics (Research of the Problem of Utilization of Morphogenetic Regularities of the Animate Nature in Architecture)*”. Shortly after that Lebedev published his first monograph that was based upon his Ph.D. thesis (Lebedev, 1971). In this book he extended the theory of architectural bionics especially aesthetic analysis of modern architectural forms inspired by living nature. Lebedev impartially criticized “biological naturalism” that was just superficial copying of natural shapes without understanding of their functional origin in nature and their suitability in architecture.

The second edition of this monograph was considerably revised and enlarged with results of latest researches and was written much more simply and clearly as a popular science book (Lebedev, 1977). It was no coincidence that exactly this edition was translated in several languages.





The German translation of this book (Lebedev, 1983) until now according to some recent publications (Gruber, 2011, Pohl, Nachtigall, 2015) remains the only source of information about the Soviet architectural bionics beyond Russia.

In the middle of 1960s a group of like-minded persons (architects, engineers, biologists, mathematicians and artists) started to arise around Yuri S. Lebedev and his ideas. At that time he worked for the Research Institute of Theory, History, and Perspective Problems of Soviet Architecture in Moscow (now its name is *the Research Institute of Theory and History of Architecture and Urban Planning*) where in 1970 it was organized a laboratorial group of architectural bionics. In 1984 on the base of this group the Central Laboratory of Architectural Bionics was established. Among its duties was coordinating of researches on architectural bionics on the national scale in the USSR.

## Theory of Architectural Bionics

The origin of architectural bionics in the theoretical and historical institution considerably influenced the way of its further development as well as forming of its own theory. The theory of architectural bionics inherited the Soviet architectural theory of 1930–1950 with its neoclassic approach to architectural composition. In spite of conservative restrictions of this theory many Soviet architects of that time such as I. V. Zholtovskiy and M. J. Ginzburg emphasized the importance of studying animate nature and compared good-designed buildings with natural organisms. This theoretical background enforced Yuri S. Lebedev and his group to search for analogues not only between natural and architectural structures and functions but also between their fundamental compositional and forming principles such as architectonics, symmetry, proportions, modularity, rhythm, expression of forms, etc. The final goal of these researches was the theory of harmony of artistic and technical means in architecture by analogy with holistic essence of animate nature. At the same time this theory might serve as an objective and scientific base for the harmony between architecture and nature as well as between the global artificial environment and the natural one.

The harmony in the animate nature dynamically interacts with disharmony as its dialectical complementary opposition. The balance between them constantly breaks and restores again. As opposed to inorganic nature characterized by entropic processes, the animate nature based upon negentropic or informational processes which increase the order of living systems and enlarge their quality diversity. Thanks to these properties the animate nature is able to self-organize, self-develop and self-improve. The main subject of architectural bionics is dynamic harmony of dynamic balance manifested in informational processes both in animate nature and architecture.

Architectural bionics as a science characterizes by indissoluble unity of its theory and practice. Together they constitute architectural-bionic method of functional analogies or comparison of form-generative principles and means in the animated nature and architecture and an operational algorithm of the method. This algorithm can be divided into three stages: 1) bionic researches of natural forms, structures and processes; 2) physical modelling of natural analogues; 3) design of real architectural objects and making necessary adjustments in the initial natural analogues.

On the stage of preliminary bionic researches it is important to abstract away from naturalistic copying of natural prototypes in order to reach the principle level of the general mathematical and physical laws. These laws are common for all material objects including natural and architectural ones. On the base of the general laws it is possible to achieve a real scientific approach to bionic method and make it a real scientific discipline.

## Architectural Design Based on Bionic Method

Among the general forming laws that were studied and developed in the Laboratory of Architectural Bionics in 1970s and 1980s there were such conceptions as interaction between the gravitation and growth, geometry of spiral growth, structural modularity, branching as a forming principle, mathematical laws of egg-shaped shells, natural principles of stable tall building, reversibly transformable foldable envelopes, resilient transformable grids, self-tensional systems, woven and knotted structures, etc.

The general laws were taken as a basis for different architectural and structural design projects. One of the earliest architectural-bionic designs accomplished in the beginning of 1970s was based on the principle of spatial spiral rotation that was named “*Turbosoma*” that means “*Twisted Body*” (Figure 1). The spiral twisting around a straight or curved axis is typical for stems and trunks of plants. The cross-sections of these twisted shapes have equal or similar configurations. This structural principle enables plants to strengthen their vertical stability without enlarging their mass as well as provide them with better resistibility to wind pressure.

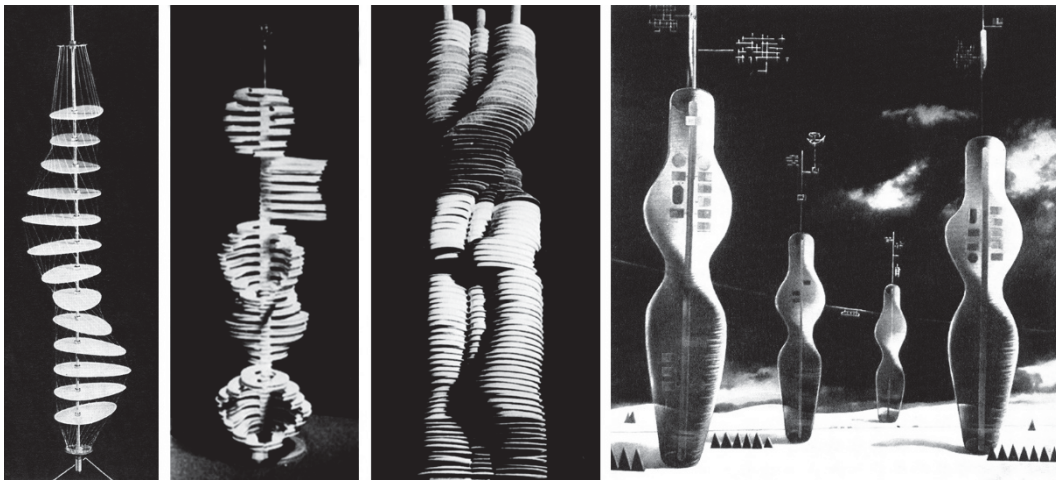

Figure 1. Architectural forms of tall buildings based on “*Turbosoma*” principle.

The same principle forms skeletal tubular bones of humans and animals in order to stiffen them and give them better adaptation for movements and control of muscles. At the same time the twisted form have beautiful dynamical shapes and organically blend with natural surroundings. A special manifestation of the same principle is the law of phyllotaxis: a regular spiral distribution of leaves and branches along a plant stem that may be described with different number sequences including Fibonacci numbers.

The principle of *turbosoma* may be utilized in architecture of tall buildings with unified story levels rotated along vertical elevator and communication shaft. It may provide the buildings of this type with evenly distributed insolation, better wind resistive capacity, and multiple variants of architectural composition depending of the angle of story levels rotation and of continuous or discrete type of rotation. In addition this principle gives the possibility to design really rotating buildings e.g. following the sun or deviating from strong wind.

Reversible movements of forms and elements are typical for many objects of animate nature. In bionics they are described as transformations: bending of branches, movement of wings of birds and insects, opening and closing of petals of flowers, etc. Initially researches of transforming structures in the Laboratory of Architectural Bionics included folding structures of rigid flat and non-

flat elements, structures based on the principle of developable surfaces joined together with hinges, and resilient-flexible developable surfaces.

The principle of folding structures consists in dividing of a flat solid sheet into a number of facets with hinges between them. A folding structure is a kinematic mechanism with many degrees of freedom that let it form arbitrary shapes, but only few of them have structural stability. In animated nature folds serve to strengthen surfaces as well as to change their surface area for different processes of functional interactions with the environment. The architectural-bionic method makes it possible to reveal the natural achievements in the folding principle to utilize them in architectural and engineering designs (Figure 2).

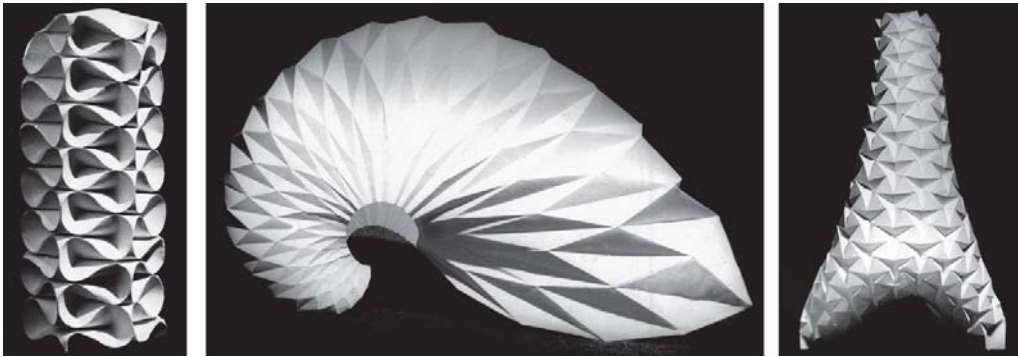

Figure 2. Modelling of natural forms with folding structures.

In the Laboratory of Architectural Bionics there were designed and modelled new types of folding domes, cylindrical and hyper shells (Figure 3). In addition it was elaborated a method of modelling of complicated biomorphic shapes by means of transformation of continuous flat plates similar to origami. There were also experimental models of foldable structures with curved hinge connections and foldable structures with non-flat elements: cylinders, conoids, and surfaces of double negative curvature.

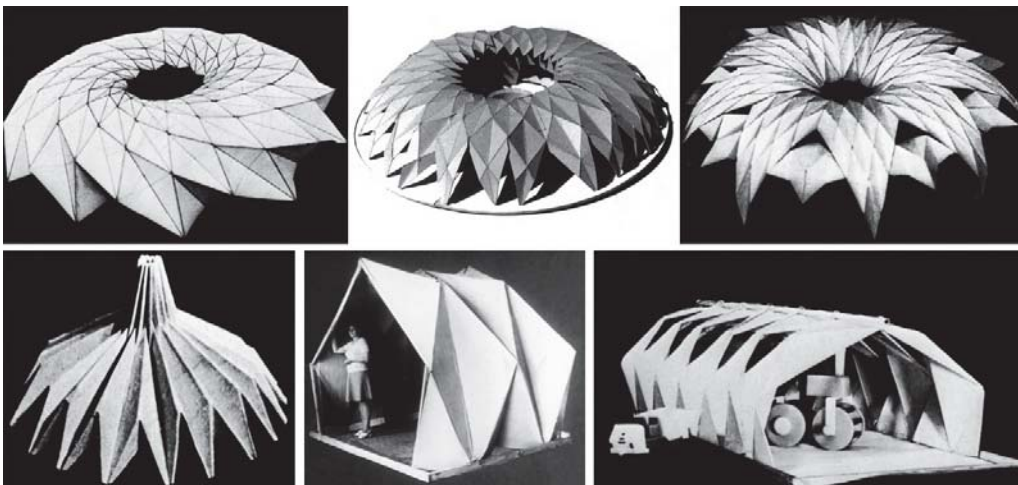

Figure 3. Architectural applications of transformable folding structures.

Practical applications of folding structures as roofs and envelopes demanded special technical solutions such as composite multilayered structures with rigid flat elements placed between two

sheets of waterproof fabric and glued to them. At the joints of flat element the fabric sheets were stitched or welded together in order to form waterproof seams that served as hinges.

## Bionic-Based Resilient Structures

In the animate nature transformations are connected not only with physiological functions, but also with the effect of mechanical loadings, optimization of mechanical work provided not only by moving of structural elements but also by tissue elasticity. For example, branches of a tree do not break during the storm, but bend in search for better conditions for mechanical work they are doing: that is what nature actually “invented” them for. A human skeleton and muscles take the most diverse configurations depending on the position of the load they carry, etc.

There is a phenomenon closely connected with flexible-elastic tissues which got a name of resilience in biomechanics. It is defined as a certain quality of elastic energy, accumulated in a material and a structure without causing its damage. The accumulation of elastic energy takes place because of increase of deformation in material and structure. But this very deformation growing progressively contributes to the better accumulation of elastic energy, lessening of the weight of the structure and increasing of its durability. Many kinds of tissues of the animate nature have great capacities for elastic energy accumulation. For example, human tendons are capable of storing elastic energy twenty times greater than that of modern spring steel. However, it is this elastic energy that can cause destruction. In this respect measures against cracks in material or measures promoting viscosity of material are very important.

Thus, structures of animate nature combine qualities of perceiving static (stiff tissues), as well as dynamic (flexible tissues) loadings. Stiff parts are inertial ones and accumulating of elastic energy in them is a slow process. Flexible parts are impulsive ones; they absorb and deliver elastic energy rapidly in response to dynamic loadings. This is a very important consideration in terms of destruction of structures.

One of the most prominent results obtained in the Laboratory of Architectural Bionics were rod-cable flexible-elastic structures based on ribbon fragments of linear developable surfaces joined together with hinges. The structures of this type were assembled on a plane surface and transformed into spatial position by means of folding and rotation of developable linear ribbons in one or two directions. The structures were able to take many different shapes including the shape of roll suitable for transportation (Figure 4).

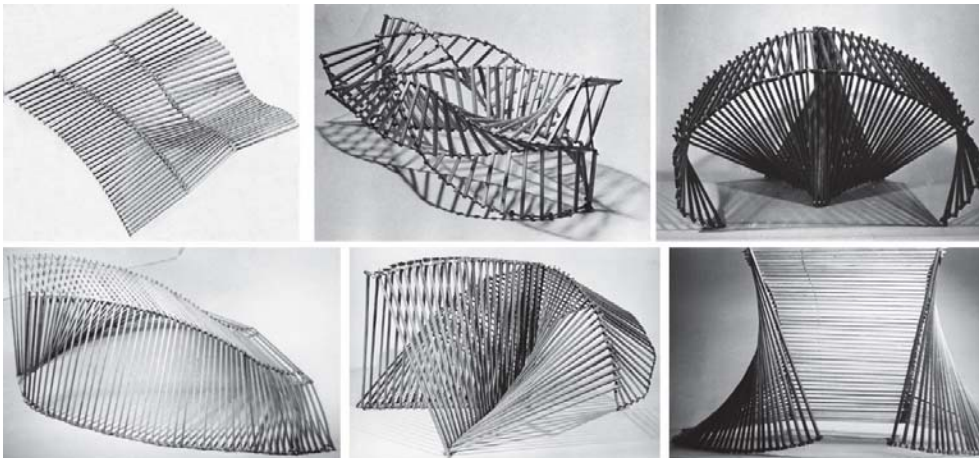

Figure 4. Transformable rod-cable flexible-elastic structures.



The structure in flat unfold position consists of staggered beams of wood, metal or plastic with metal ball hinges placed between the ends of neighboring beams which may be reinforced by metal anvils. The beams and balls have small round through holes and are connected with each other by means of metal cables passing through them. As a variant of the same structure the ball hinges are substituted for the cylindrical ones. This gives the possibility for better distribution of the distances between the beams and for optimum correspondence of weight and durability of the structure. A three-piece section of the structure makes it possible to get several different form variations by means of its pre-stressing with few additional tightening devices. In animate nature it is trochanteric joint of the human femur that serves as the prototype for this structural principle.

An improved variant of this structure was done with prismatic wooden intermediate pieces functioned as hinges that enabled reducing of weight and optimization of assembling. It was used for cylindrical vault frames of hot-houses, garages and other coverings which were plant-fabricated with utilizing waste of woodworking industry. The frames had height of 2 m, covering area of 22 m<sup>2</sup>, and were strong enough to carry distributed load of 2 t. Together with doors and door-boxes included into the butt diaphragms, the weight of the frames was about 100 kg. Two persons assembled them in about 30 min. For better storing and transportation the frames were foldable and were able to be cut into parts along the cylindrical vault and jointed back while assembling.

Based upon this structural principle a mobile cross-shaped dwelling block with social and domestic services for 20–22 people was designed and suggested for oil-industry workers, timber-cutters, and geological survey workers of the North. In 1984 the model of this block was exposed at “Tsukuba-85” exhibition in Japan. The composition of the block could be changed in order to get different star-shapes with five, six and more rays.

One more type of transformable resilient structures invented in the Laboratory of Architectural Bionics were wooden developable from plane grids reinforced with flexible bands. The structure of this type was composed of small bars with ends of inner arc shape and longitudinal round rods with the same radii as of the bars ends. Top and bottom sides of the bars were joined to continuous resilient-flexible bands and the rods were inserted into the round holes formed by the pairs of arc ends of the neighboring bars (Figure 5, left). The flat flexible grid structure had an ability to transform into conical, cylindrical or doubly curved surface shapes and become resilient and reinforced because of tension of the bands and compression of the bars (Figure 5, right). For convenience of transportation the structure was divided into the chains of bars connected to the bands and the rods. The results of probes demonstrated that the resilient-flexible structures could be three times lighter in weight under equal loading as compared to rigid ones.

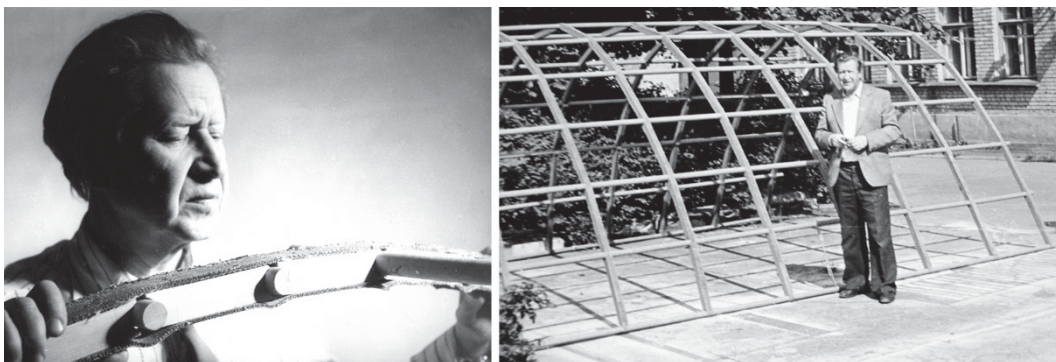

Figure 5. Left: Yuri S. Lebedev with arc of resilient transformable grid structure; right: Yuri S. Lebedev with completed vault of transformable resilient grid structure (photos of the end of 1970s).

Because of simplicity and low cost of these structures that did not include any metal parts they became the most popular bionics-based production in the field of building in the USSR. They were used as cylindrical convertible hot-houses and coverings of mobile houses and garages. Some designs of permanent architectural objects were also suggested. Here again architectural-bionic method was applied not just for copying a natural analogue but to elaborate general principles of resilient-flexible structures. These principles are common to the structures of plants and animals subjected to considerable reversible transformations and deformations of their elements.

## Practical Activities of Architectural Bionics

Practical applications of the architectural-bionic methods in architecture were difficult in the period of 1970s–1980s in the USSR. The total regulation and reductive approach in architectural design left no room for bionic innovations in the Soviet building industry of that time. A rare exception in this tendency was an experimental dwelling unit for the Soviet drifting research station “North Pole-25” with the above-mentioned resilient-flexible frame grid reinforced with bands (Figure 6). The unit successfully functioned since 1981 until 1984, when the station finished its work.

The unit was warmed with three-layer coating: tarpaulin, flannel, and coarse calico. Weight of the unit was 240 kg. Between tarp and flannel the air cavity was left with thickness of 4 cm equal to that of structural vault elements. Inside the unit a petroleum stove was installed that made it possible to keep inner temperature of  $+18^{\circ}$  –  $+20^{\circ}$  C when the external one was up to  $-30^{\circ}$  C. In periods of lower temperature the unit was used as a store-house. The structure of the unit resisted to wind load up to 30 m/sec without spreaders. The unit was brought by air to the drifting ice field in folded form. After transportation the basic structure was assembled in 40 min.

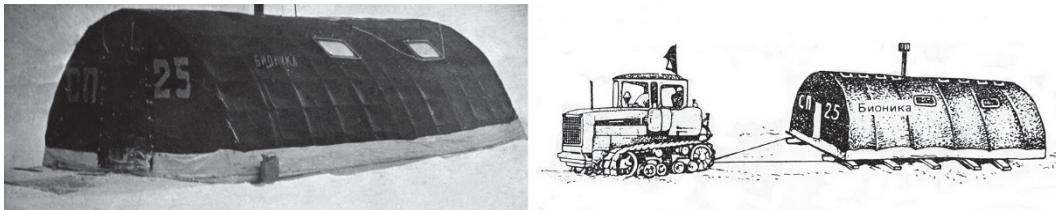

Figure 6. Resilient transformable grid structure served as dwelling unit at the Soviet drifting research station “North Pole-25”.

In the 1980s the results of scientific and design activities of the Laboratory of Architectural Bionics were known not only in the USSR and in the countries of the East Europe but virtually worldwide. In 1983 the cooperative German-Soviet exhibition “Lightweight Construction in Architecture and Nature – Architectural Bionics” was held in the Shushev Museum of Architecture in Moscow. The organizer of the exhibition from the German side was the Institute for Lightweight Structures of the University of Stuttgart headed by Frei Otto. The exhibition had great success and lately was demonstrated in Germany. A special issue of the Information of the Institute for Lightweight Structures was completely dedicated to this exhibition (Otto, Lebedev, 1983).

The cooperation between Yuri Lebedev and Frei Otto started in the middle of the 1970s and took the forms of conferences, exhibitions, and publications. Lebedev was a member of workgroup “Biology and Building” that was established by Frei Otto in the early 1960s. The culmination of this cooperation became publishing an international monograph “Architectural Bionics” (1990). The book included a special chapter written by Frei Otto and his colleagues as well as chapters by Paolo Soleri (USA), Andrei Moutnyakovitch (Yugoslavia), Oscar Buttner (German Democratic Republic), Mikhail Sharafin (Czechoslovakia), and Matei Mateev (Bulgaria).



In 1990 two design works by the Laboratory of Architectural Bionics were included into UNESCO catalogue dedicated to simple roof-building techniques of natural local materials like bamboo. The project was headed by Yona Friedman, who collected simple and reliable building structures and technologies for the people with lowest income in India. In this catalogue were presented transformable light-weight bamboo dome structures (Kozlov, 1991a) which I started to study and test at that time (Figure 7). I started my collaboration with Yuri S. Lebedev and the Laboratory of Architectural Bionics in the middle of the 1980s when I invented a new type of resilient transformable structures based on topological knots and links (Kozlov, 1989). Knotting is a widespread natural way of structural organization of flexible lengthy objects, e.g. long polymeric molecules including DNA. Some woven natural structures such as the braids of heart muscles and the framework of squid mantle function as transformable resilient mechanisms similar to complicated knots. Weaver birds make their nests utilizing knots and hagfishes can tie themselves in knots.

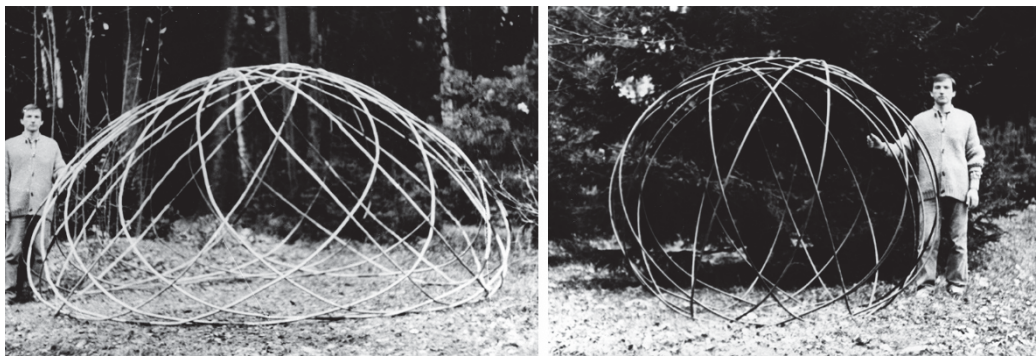

Figure 7. The author with transformable light-weight dome structures based on knot principle (photo of 1990).

Knots tied with resilient filamentous materials tend to take the minimum value of their elastic energy and turn into cyclic loops of equal size. The principle of cyclic periodicity may be extrapolated from simplest knots to complicated ones and turn them into transformable resilient structures. These structures work as tensegrity: they are compressed at the contacting crossing points and stretched inside the spans between them. Pressing on the peripheral points of the flat structure of cyclic knots increases its inner elastic energy and force them to transcend the plane and takes the form of spherical segment. This principle of form generation makes it possible to create surfaces of different types, such as elliptic and hyperbolic, torus and pretzel shapes, forms with different numbers of self-crossings, including knotted and one-sided surfaces. The structures of this type were designed by the Laboratory of Architectural Bionics for extreme conditions of construction: on the North, in deserts, in high lands, under water and in open space (Kozlov, 1991b).

## Conclusion

Architectural bionics was a branch of a global trend in design-science that started worldwide in the 1960s. In the Soviet Union this trend took form of an architectural theory which included both aesthetic and engineering aspects namely architectural-bionic method. Its systematic applications by scientists and architects of the Laboratory of Architectural Bionics in Moscow as well as by the specialists in other parts of the USSR and in foreign countries (Czechoslovakia, the German Democratic Republic) allowed to reveal fundamental form-generative and structural principles and

to create a new vision of formative processes and technical means of animate nature that had led to different innovative solutions in architecture and building.

Specifics of architectural bionics consists in combining of the natural laws with the laws of art and aesthetics such as psychology of perception, influence of cultural context, rules of composition, and so on. In addition these laws meet with technical and building conditions: economy, technology, target function, availability of proper materials, etc., and harmonic integration of them is the main task of architectural bionics. Method of architectural bionics as opposed to pure quantitative computational methods joins together abstract and specific principles: mathematics of forms and their emotional expression, utility and aesthetics. It creates a potential base for the synthesis of science and art that makes it possible to solve effectively different practical problems of contemporary and future architecture.

The limited size of this paper leaves no space to write about such fields of architectural bionics as bionic approaches to ecological building and town-planning, possibilities of bionics in supporting of climate comfort of interiors, combinatorics and modularity in animate nature and architecture, and many others. This paper is dedicated first of all to the history of architectural bionics that now is practically unknown beyond Russia and some of the post-Soviet countries. The heritage of architectural bionics today may serve as reliable foundation for modern bionics (biomimetics, biomimicry) in architecture and design including theory, scientific researches, modelling, and education.

## References

Gruber, Petra, *Biomimetics in Architecture. Architecture of Life and Buildings*, Springer-Verlag, Wien–New York, 2011.

Kozlov, Dmitri Yu., “Dome Structures for Flexible Material”, in Friedman, Yona (ed.), *Roofs, Part 1: Human Settlements and Socio-Cultural Environment*, pp. 127–131, UNESCO, Paris, 1991a.

Kozlov, Dmitri Yu., “Polymorphous resilient flexible shaping structures “NODUS” for space and other extreme environments”, in Bell, Larry (ed.), *Proceedings of the First International Design for Extreme Environments Assembly (IDEEA)*, pp. 259–260, University of Houston, Houston, 1991b.

Kozlov, Dmitri Yu., “Regular knots and links – the structural principle of kinetic architectural structures”, in Lebedev, Yuri S., (ed.), *Architectural Bionics, Collected Scientific Works*, pp. 72–82, TSNIIEP Zhilischa, Moscow, 1989 (in Russian).

Lebedev, Yuri S. and Zefeld Viktor V., “Structural Systems in Architecture and Vegetable Kingdom”, in Borisovskiy, Georgiy B. (ed.), *Problems of Contemporary Architecture*, issue 1, pp. 111–154, Stroyizdat, Moscow, 1962 (in Russian).

Lebedev, Yuri S., *Architecture and Bionics*, Stroyizdat, Moscow, 1971 (in Russian).

Lebedev, Yuri S., *Architecture and Bionics*, revised and enlarged 2nd edition, Stroyizdat, Moscow, 1977 (in Russian).

Lebedew, Jurij S., *Architektur und Bionik*, MIR, Moscau, Verlag für Bauwesen, Berlin, 1983.

Lebedev, Yuri S., et al., *Architectural Bionics*, Stroyizdat, Moscow, 1990 (in Russian).

Otto, Frei, Lebedev, Yuri S., et al., *Catalogue of an Exhibition in Moscow “Natural Structures” (IL-32)*, Institute for Lightweight Structures University of Stuttgart, Stuttgart, 1983.

Pohl, Göran, Nachtigall, Werner, *Biomimetics for Architecture & Design. Nature–Analogies–Technology*, Springer, Cham–Heidelberg–New York–Dordrecht–London, 2015.



# Responsive Spicule Systems

## Simulation & Alignment

Elias Darham<sup>1</sup>.

<sup>1</sup>*Southern California Institute of Architecture, Los Angeles, California, United States.*

<sup>1</sup>*ejdarham@gmail.com.*

**Abstract.** This paper will address the topics of robotic simulation, responsive systems, and computation through the lens of discrete component systems. Through design research tested at SCI-Arc's Robot House, this author will attempt to advance the potential of discrete component assemblies for architectural purposes. The spicule tectonic research presented here was part of a larger exploration of low-level AI as a means to achieve structure and architectural mass inside an urban infrastructure. The culmination of this project was a simulation of a spicule component system using robotic arm technologies to test material alignments and modes of assembly.

**Keywords.** *Discrete; Spicule; Robotic; Component; Alignment.*

## Introduction

The modular component assemblies have a long history within the field of architecture. However, their history has also been plagued by repetition and material error. Since the introduction of advanced digital modelling and robotic fabrication to architecture, the divide between digital and material strategies has been increasingly dissolved. At the same time, the ability to diversify or complicate relatively simple systems has led to a conflict between mass-customization and computational complexity. Discrete computation offers a contention seeking to respond to this conflict. The discrete approach to the transformation of matter synthesizes rulesets that are simultaneously digital and material while augmenting the localization of response and affect.

Through design research tested at SCI-Arc's Robot House, this author will demonstrate the potential of discrete material computation for architectural purposes. The research presented here was part of a larger exploration of low-level AI as a means to achieve structure and architectural mass inside an urban infrastructure.

The culmination of this project was a simulation of a discrete spicule component system using robotic arm technologies to test material alignments and modes of assembly.

## Autonomous Processes

Autonomy in this project is not confined to the aspirations of formal production; the resilience of process is central to the performance of the responsive spicule system. is maintained through identification and activation of initial volumes of operation.

both co provides becomes an opportune method to achieve continuity in the process of design. These volumes act in such a way as to preserve authorial autonomy while intensively advancing the autonomy of material processes. Consequently, the produced design object permits author and autonomous process to operate without conflict.

The responsive aspect of this project is procedurally based. Using agent-based computation, the performance of agents plays out iteratively. Unlike "live" or mechanically responsive



mechanisms, a procedural approach is computationally inexpensive and may be implemented within a larger architectural response. This packaging of responsive systems enables a greater degree of access and freedom for a designer.

In this project, the use of agent-based computation makes use of perceived contextual figures as the seeds for discrete formal operations. The direct output of this autonomous manipulation of figures in context is the basis for the discrete component system. As the flattened contextual image increases in dimensional complexity, these figures gain volume and discrete material qualities of their own. In comparison to traditional modular systems, discrete components permit multi-scalar aggregation from self-similar units while liberating design from determinate organizations.

To this end, a discrete system takes advantage of redundancy through the localization of component responses. If a moment where multiple rulesets are in conflict within a discrete system, the response is kept local in such a way as to differentiate it from the whole while also not applying the response globally. In this way, redundancy and error are transmuted into productive alignments with material and digital implications. Error and repetition become instrumental to achieving a larger coherency of mass without prejudice. This paper advocates for the implementation of partially autonomous systems of intelligence for the coordination of discrete assemblies and the intercommunication of parts and masses.

## Project

The project described in this paper must be placed within the context of the Master of Design Research final project studio at SCI-Arc, advised by Marcelo Spina and M. Casey Rehm. The aim of the studio was to develop a computational platform for the transformation of a discrete agent-based behavior into architectural form. Critical to this goal was the understanding of figures as a base syntax for tectonic computation. A volumetric understanding of the figure was essential for the alignment of computational and material intelligences so as to understand the impact of figure in the compressed context, thereby indexing tectonic volume inside the figure. The ultimate architectural contention of the studio was that the consumption of monolithic volume and figuration by tectonic behavior may be subverted to produce an architectural object with profound character and intense complexity. In this way, architectural objects can exist in a continuous state of transformation; figure into volume, volume into tectonic, tectonic into edgeless figure.

In the context of discrete material computation, this project utilized low-level AI as a means to autonomously develop planometric drone imagery into form. Subsequently, the natural matter of the city is not only material values, but also augmentation of context by architectural form. The role of AI towards the end of the project was to transform the augmentation into material simulation. Between material informing figure, figure informing augmentation, augmentation informing context, and context informing material, a selectively autonomous loop is made in the project. This loop then serves the continuity of discrete computational processes.

As a design experiment, the advantage of using the Robot House was two-fold. First, the autonomy of the robot enables the complete transformation of holistic material into discrete material information. Second, the robotic arm is a discrete fabrication tool capable of liberating the designer from simply abstract (bereft of allegory) means to represent the architectural process. In a way, "Digital Data becomes the same as physical data. Computation and fabrication can happen in parallel, with the robot computing and evaluating the assembled structures while building them." (Retsin & García, 10). The simulation of the design thus becomes both representational artifact and literal object of the design process.

## Figures & Volumes

The urban context of Mexico City offers a wildly dichotomous scenario in which the presence and restriction of advanced technologies is pitted against the edgeless density of congestion. For this reason, the site of Glorieta de Insurgentes offers the ability to respond discretely to a pervasive congestion of infrastructural, pedestrian, and economic pressures. Specifically, this project decided to bridge the glorieta and extend the outline of the figure to along the principal axis of the site (Avenida Chapultepec) in order to take advantage of the metro below and the disused parking areas on the ground. What better a site in which to negotiate congestion and the need for provocative engagement of architecture?

The production of figures in this context served to mediate between surrounding context and the glorieta. Using drone imagery, the context was rebuilt as a planometric image. The machinic flattening of context into image, this author argues, compresses the possible syntax for response. The selected site was then inserted into the image as a silhouette and treated as visually neutral as the context [FIGURE 1]. This image was then brought into processing and analyzed for brightness levels. The analysis logic to identify figures here isolated intense areas of brightness and darkness, roughly the lower and upper tenth percentiles. By partitioning the image into buckets of pixels, not only was a scale assigned to the components, but an interplay between contrasting figures was also set up, creating a dynamic, yet discrete relationship between volumes.

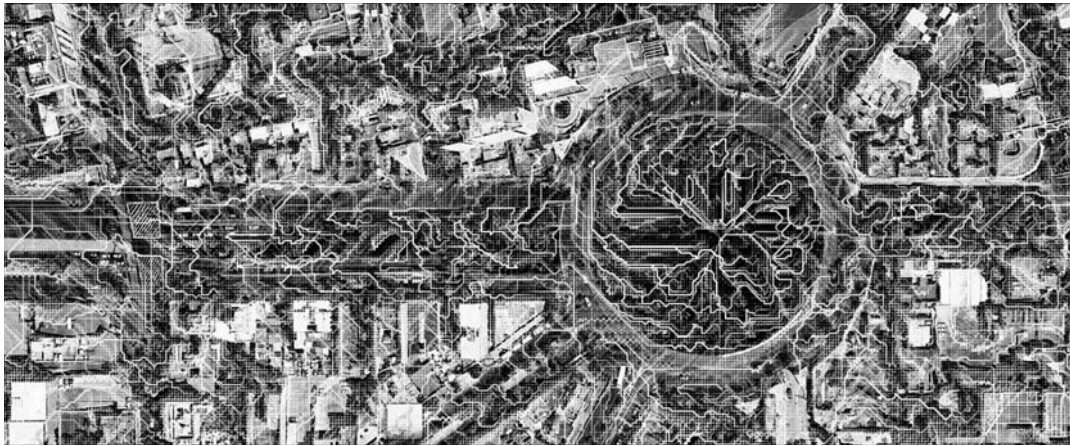

Figure 1. Autonomous processing of site with figure.

The figural emerges here to re-insert the designer within the autonomous process of context. On one hand, the inclusion of the selected site instigates some determination of response, while the use of processing for discrete agent based behavior that is activated autonomously is clearly an autonomous production of volume from partially autonomous context. As an author of tectonic content, the designer is thus able to direct the activation of material strategies while maintaining the autonomy of the process. As time goes on, the agent based behavior transforms determined volumes into seemingly edgeless figures. The output from processing was then brought into Rhino and Grasshopper as instances of spicule component elements.

The use of interlocking spicule components in this research project offers a wide range of applications and adaptability for a component-based system. Not only may these self-similar components be adapted from a single parameterized definition, they can also aggregate to form a larger series of super-components [FIGURE 2]. At the scale of buildings, these spicules offer the architect with a system that will autonomously comply and edgeless-ly redefine tectonic volumes.



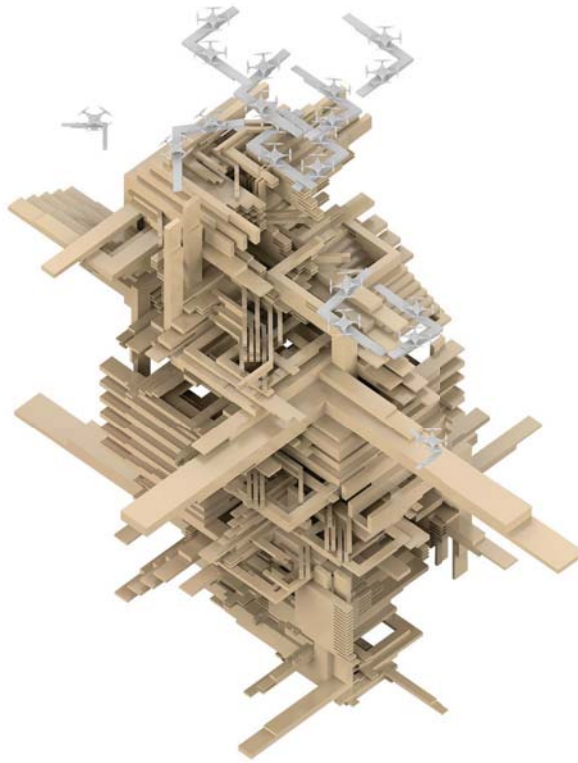

Figure 2. Super-composition of Spicule Components.

In contrast to continuous modes of fabrication, such as robotic arm 3D printing, a discrete component system is not indifferent to the volumes in which it operates. The fuzzy volumes described here are not so simply defined that a global strategy may suffice to direct fabrication. The discrete volumes here are not simply repeatable or part of an alphabet of different instances of interactions; discrete methods for the development of volume can localize instances in which. In this way, discrete methods identify locations of tectonic change without incorrectly determining directional change. In a broader context, this resonates with conflict between the digital desire for variation and the false assumption of malleability. The potential for volume to be incompatible with globally defined responses is made clear when it is demonstrated that, "...this desire [the desire for complete malleability] loses traction when applied to methods falsely assumed to be repeatable..." (Clifford, 3). In this way, a discrete system can easily avoid the criticisms of globally and continuous material computations.

As a commitment to the success of the project, the use of machine vision and low-level artificial intelligence resonates with to the means of construction and complexity of figural outcomes. This project used AI to objectively extend and propel the intervention of mass over time. In terms of production, the decentralized mode of robotic assembly is favored in order to maintain the continuity of the performance while maintaining the discrete nature of the design. This project's divergence from continuous modes of assembly may be easily simulated and actualized through robotic assembly of scaled components.

The overarching architectural volumetric effect is the sublimation and instrumentalization of mass by tectonics. In short, a figural mass comes into being with no determinate boundary but only of continual configuration and intelligence.



## Spicules

Spicules, or minute needlelike structures commonly found in sea sponges, calcite, and ice, offer discrete computation with the opportunity to play with multi-axial, self-aligning modular component systems [FIGURE 3]. While research into discrete component systems has been undertaken at UCL Bartlett, the components themselves have been, for the most part, monaxial. The advantage of these linear, discrete elements is that any directionally oriented effect may be easily covered by such components. The potential defect of the monaxial kind of system is the one-size fits all response that has inadvertently avoided multiaxial tectonic interactions between components. In short, what happens when orientation matters within the component?

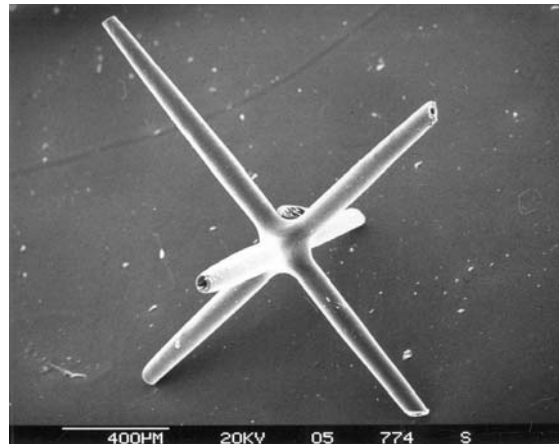

Figure 3. Sea sponge Spicule, multi-axial.

The basic structure of the spicules in this project took the form of L-shaped components with lap joints extending twice the width of the cross-section. The cross-section itself, is rectangular, permitting a greater degree of complexity and computation. While a diamond cross-section offers a simple case for self-alignment, a rectangular one forces the design to reconsider self-alignment in eccentric, more common, material conditions. Due to its L shaped form, the component inherently determines a placement plane. Within a simulated stack, the component's orientation plane indicates the order in which it is placed.

The joint for the spicule component became crucial to the ability of the component to enable variation without over-mining the variation needed to produce substantial change within the assembly system. For the components used in this project, an eccentric scarf splice joint was used to connect components [FIGURE 4]. This joint offered the spicule components with the ability to slide into position and rest in place. At the scale of the simulation, the components were too small to accurately replicate the intended scarf splice. Consequently, a simplified lap joint was used to join components. The resultant change in the simulation confined the autonomous assembly to the xy oriented components. Due to its L shaped form, the component inherently determines a placement plane within the stack. This decision, in contrast to using linear elements, indicates the potential for the system to change direction within every multi-axial component that is implemented.

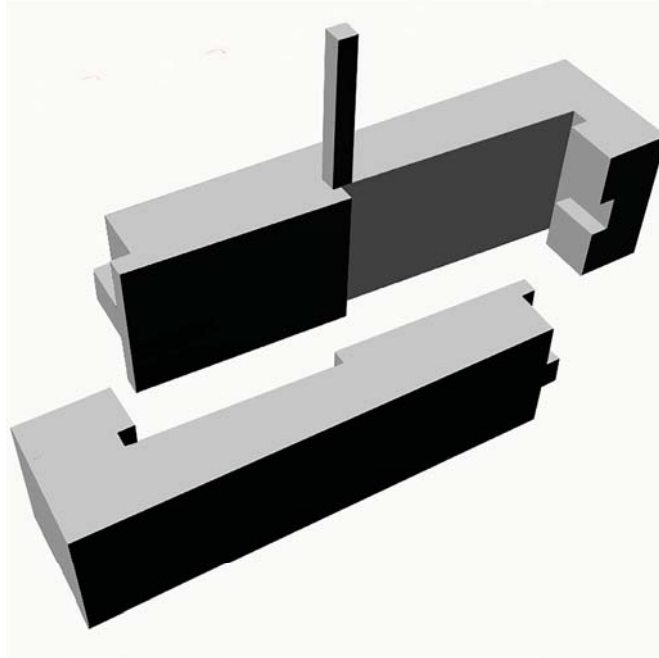
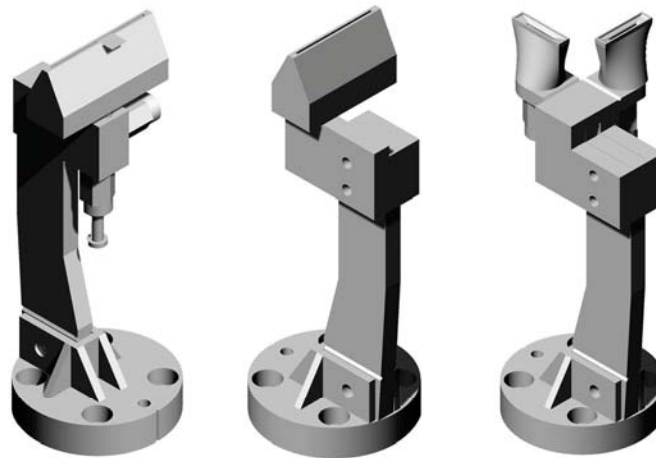

Figure 4. Scarf Splice Joint.

### Simulation

The use of robotics in architectural research enables the material simulation of complex processes and autonomous means of production. The literality that this sort of simulation offers imbues architectural modeling with material realities. In a conceptual position, the autonomy of robotic fabrication objectively exploits various tolerances in the project to the extent that an autonomous material simulation is indistinguishable between the representational object and an experimental likeness of material processes. This likeness is amplified to the degree that that, "...digital designers do not need to simulate material affects to try to anticipate the fabricated results. Instead, their assumptions can be tested and calibrated simultaneously. The time distance between output, evaluation, and modification are reduced to milliseconds, so that design intentions can be expressed without compromise." (Batliner, 401). In so doing, this compression adds to the autonomy of process while intensifying the degree of representation within the object.

Robotic simulation required the design and production of a tool with which the robot could pick, place, and release components. Due to the L-shaped, rectangular cross-section design of the spicule components, a simple pneumatic picker was insufficient to successfully retrieve components from the staging plate. Over the course of five variations, an Air-Knife design was inverted to maximize suction along the principal axes of the L-spicule and be mountable to the tool plate of the robot arm [FIGURE 5]. Further calibration was needed in order to transform the robotic arm tool point so that the robot accounted for the shift in the z-plane from the robot end plate to the pneumatic tool plane. Once this transform function was recorded, the digital simulation could then be generated to determine the assembly sequence and output data for direct robotic implementation.



*Figure 5. Air-Knife pneumatic tool.*

As described by the component within the stack, the assembly sequencing order was critical to the success of the simulation. In the digital simulation, a sorting algorithm was made to determine the order in which the components needed to be set down. This was achieved by arranging the orientation along the z-axis through the center of the stack. Cantilevered or unsupported components were then identified in order to either remove or insert components to support them [FIGURE 6]. Over the course of several iterations of sorting and supporting, the stack gained structural integrity and was properly sequenced for autonomous assembly.

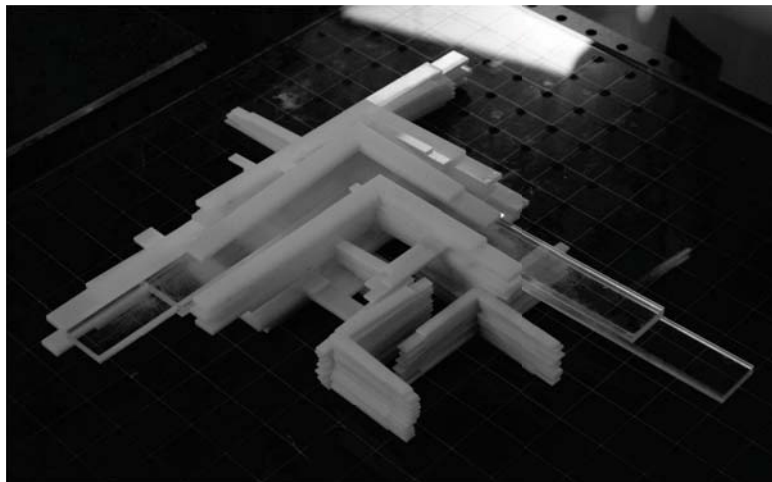

*Figure 6. Robotically simulated stack with support spicules.*

The transfer of the simulation to physical output in the robot house required two platforms for the robot to access; one to pick up the components, and another plate to release them. An additional set of retraction points were added to the robot input so as to ensure no conflict between the robot arm and the placed components.

In all, the experiment was successful, but the margin of error built into the scaled components misplaced their target plane, and so caused a couple components to overlap in ways that would require multiple autonomous component deployers. After reviewing the sequencing order, the stacking could then proceed. As a result, it became clear that multi-axial spicules that enclose a cell require a more complex approach. These components must slide under one component while resting on top of another that is placed at the same time. The synchronization that would be required here would be more achievable with a drone swarm [FIGURE 7].

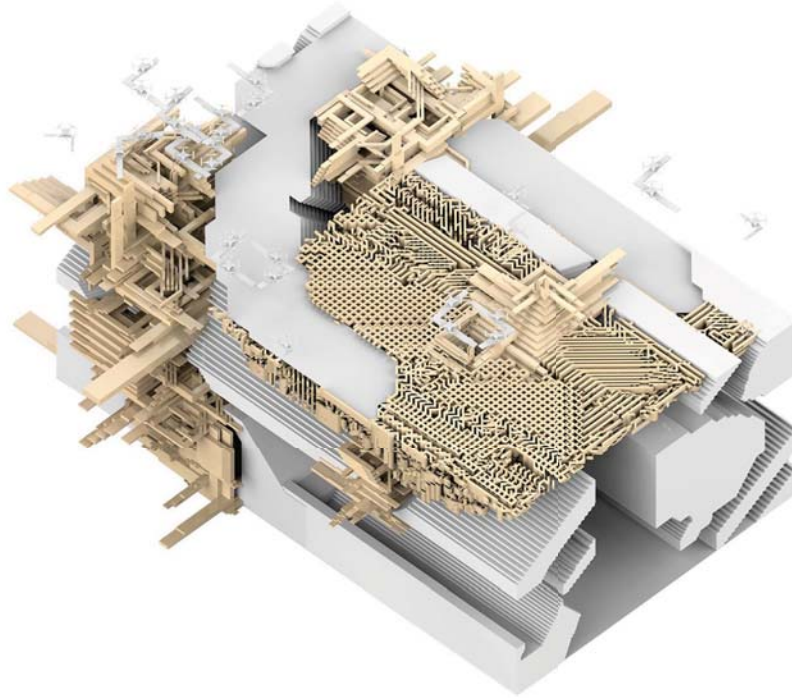

Figure 7. Drone swarm coordinated spicule placement.

## Alignment

The literality of discrete simulation engages material computation in a scenario with physical output. Yet, the degree to which the material computation is correlated with the robotic output is indicative of near equivalency. The autonomy of the robot, in this case, provides the process to abstract itself from human error and have direct, autonomous effect on physical output. With the use of robotic arm fabrication for component assembly, an alignment is made in the process between the computation, representation, and the physical output. The alignment of material and autonomous processes thus produces an alignment.

By no means is this the limit of alignment in this project. Alignment here extends into the design of the tectonic process itself. In this position, the autonomy of robotic fabrication objectively exploits various material tolerances to the extent that a simulation is indistinguishable between the representational object and an experimental likeness of material processes. Thus, "Aligning discrete computation with discrete fabrication enables the designer to bridge the gap between the digital and the physical." (Retsin & García, 10). This position is not necessarily novel in and of itself, but this author contends that this project goes a step further. It is the migration of architectural aura from digital to physical as a simulation that suggests the alignment, or even observable equality, of tectonic behaviour and autonomous processes (Latour, 3). The existence of this alignment



produces a super-procedural alignment containing the entire object simulation. The simulated object is, in this case, both the fac simile and the real object aura. In this way, the robotically simulated object "... described in this paper would not be [simply] considered digital" (Retsin & García, 9). The architectural object is therefore the real object of extensive simulation.

## Conclusions

This paper concludes that the implementation of discrete components engages design to formulate and propose responsive assembly systems through partially autonomous intelligence and simulation. As a result of such engagement, the potential for discrete components for a continuous and aware architecture may be put forth as a coherent material proponent of computational experimentation in architecture.

In terms of the insertion of architectural figures into context, the system proposed here successfully implements figures within the urban context of Mexico City while maintaining the autonomy of both context and form. The sort of autonomy described here is not simply deterministic, but rather gains autonomy through the intelligence of engagement at the level of tectonics to the scale of its infrastructural context. The subsequent architectural proposition is the compression of monolithic volume and tectonic assembly into edgeless autonomously intelligent figures.

The use of the robotic arm was an accurate choice to represent the majority of the positions that the designed drone swarm fabrication system could achieve. The robotic simulation of the spicule component stacking itself was largely successful. However, a couple components had to overlap in ways that would require multiple autonomous machines in order to deploy them successfully. After reviewing the sequencing order, the stacking could then proceed beyond that point, but it became quite clear that the multiaxial spicules that enclose a cell require a more complex approach. These components appear to weave into their neighbors in order to lock together. Such instances within the larger design could be more easily achieved with a sloped approach to the target plane so that the component both rotates and drops into place. Unlike a continuous model for fabrication where a toolpath is inseparable from the whole, problems such as these, "...allow [designers] to serialize problems errors in toolpaths. This allows a local optimization of the structure, avoiding the use of global, computationally expensive, problem solving algorithms" (Retsin & García, 1). In this way, these instances were managed with relative ease, digitally, and physically.

Future research will seek to physically simulate a swarm of drones in order to coordinate the placement of components that enclose cells or those that do not rest in the xy plane. Furthermore, this author seeks to develop the mechanics of how the drone would pick, translate, hold, and release full size components; not to mention that it would require self-awareness that would replicate the autonomy of the intended assembly system.

## Acknowledgements

This author is deeply grateful for the generous support and advice of M. Casey Rehm, without which, the complexity and integrity of the project would not have been the same. Special thanks to Michael J. Newsum and Marcelo Spina for their support of this project.





## References

Batliner, Curime and Newsum, Michael J. and Rehm, Michael C., " Robot UI", in Burry, Jane and Reinhardt, Diegmar and Saunders, Rob (ed.), *Robotic Fabrication in Architecture, Art & Design 2016*, pp. 320-330, Springer, Cham, 2016.

Clifford, Brandon; Ekmekjian, Nazareth; Little, Patrick and Manto, Andrew, " Variable Carving Volume Casting", in McGee, Wes and Ponce de Leon, Monica (ed.), *Robotic Fabrication in Architecture, Art & Design 2014*, pp. 320-330, Springer, Cham, 2014.

Latour, Bruno and Lowe, Adam, "The Migration of the Aura, or How to Explore the Original Through Its Fac Similes", in Bartscherer, Thomas (ed.), *Switching Codes*, pp. 320-330, University of Chicago Press, Chicago, 2010.

Retsin, Gilles and Garcia, Manuel Jiménez, "Discrete Computational Methods for Robotic Additive Manufacturing", in Del Campo, Mario and Manninger, Sandra and Velikov, Kathy(ed.), *ACADIA 2016 Posthuman Frontiers: Data, Designers, and Cognitive Machines: Projects Catalogue of the 36th Annual Conference of the Association for Computer Aided Design in Architecture*, pp. 320-330, ACADIA, 2016.



## Using Generative Design for Evaluating and Improving Energy Efficiency in Architecture

Catarina Rocha<sup>1</sup>, António Menezes Leitão<sup>2</sup>

<sup>1,2</sup>INESC-ID/Instituto Superior Técnico, Universidade de Lisboa,

<sup>1</sup>{catarina.d.rocha|antonio.menezes.leitao}@tecnico.ulisboa.pt

**Abstract.** Energy efficiency is one of the core topics in Architecture nowadays. The research here presented reinforces the importance of the use of building energy analysis throughout the entire design process, rather than just running the analysis when the model is finished. By using Generative Design, the architect can explore numerous different design options in a short amount of time, and can analyze and compare all these options using the available energy analysis tools.

In the present work, we use Rosetta as a model generating tool, Autodesk Revit as a model visualization tool, and Autodesk Insight 360 as an energy analysis tool. A workflow is proposed, using Generative Design to produce multiple design variations from the initial concept of the case study presented. The results retrieved from Insight 360 are then used to improve that design.

**Keywords.** *Generative Design; BIM; Energy Analysis.*

### Introduction

Architectural design consists in presenting a solution to a given problem. This problem, even with its various constraints, such as site, climate, construction cost, and regulations, has a plethora of possible solutions. Being so, designing implies selecting amongst several viable solutions, depending on the criteria applied. ‘Design can be seen as an evolutionary process’ (Alfaris, 2009). As environmental sustainability becomes a core topic of our society, architects are lead to design buildings with better energy performance, in order to achieve a more sustainable architecture.

An energy efficient building is the ‘one that uses the minimum necessary energy to be built and used’ [1]. Ideally, a building should be auto-sufficient, i.e., it should have methods of reducing energy consumption, of reusing energy and resources, and even of producing its own energy. Being able to design energy efficient buildings will not only bring environmental benefits, but also economic ones, since it reduces consumption and thus the economic burden of a building, compensating for the initial investments.

To promote energy-efficient buildings, regulations were created, ensuring a sustainable consumption of energy and resources. Due to these regulations, it is mandatory to ensure certain consumption limits when designing a new building. There are simulation tools that allow architects to evaluate energy consumption, such as Autodesk Insight 360 [2], a simulation engine used to perform energy analysis. Some of these tools also allow for simulations throughout the different stages of the design process. Hence, the user is able to perform a general analysis on a more conceptual stage of the work, and more detailed ones in the final stages.

Nowadays, there is also a growing body of knowledge on parametric modeling, which considerably helps architectural practice, allowing a faster method of reproducing and changing a three-dimensional (3D) model of a building. Parametric modeling consists in describing an object through different parameters and relationships between those parameters, which enables variations on the model itself (Alfaris, 2009). A mathematical approach is used to describe certain aspects of the general design intent, creating functions describing the object. The values applied to the different functions allow them to create several design options, all following the same principles



and deriving from the same parameters. This approach can generate a wide variety of design options in a short amount of time. By combining a parametric approach with an efficient evaluation system, architects can find better design options, having in mind the energetic behavior, even in initial stages of the design process.

This work proposes a parametric approach for the creation, evaluation, comparison, and improvement of models, regarding their energy consumption.

## Energy Performance in Architecture

According to the International Energy Agency, 'energy efficiency is a way of managing and restraining the growth in energy consumption. Something is more energy efficient if it delivers more services for the same energy input, or the same services for less energy input.' [1]

To ensure efficient buildings, there are regulations, at national and international level, regarding the construction of new buildings and renovation of existing ones. There is a wide variety of energy analysis tools available that comply with the existing regulations, some more complex than others, and requiring different levels of expertise. The following sections present two of the most common tools used to reproduce architecture projects, and both allow energy analysis without exporting the model to another software.

### ***Revit & Insight 360:***

Revit is Autodesk's reference Building Information Modeling (BIM) tool [3]. As a BIM software, it is able to apply semantics to modeled objects, integrating in just one file all the necessary information about the building. Revit works with building components, like walls and slabs. Unlike in Computer-Aided Design (CAD) tools, such as AutoCAD or Rhinoceros 3D, the user creates specific architectural elements, instead of abstract geometric elements. These components belong to *families*, where all the construction details are specified, including the thermal characteristics of the elements.

Revit has a connection to an online simulation platform called Insight 360 [2]. This platform uses Energy Plus (a reference tool in energy analysis) to run the simulations, and works directly from Revit. When using this energy analysis tool, the user needs to generate the model in Revit and then define the options for the energy simulation. The simulation is performed by Autodesk's servers and the results shown in Insight 360's website.

### ***Rhinoceros 3D & DIVA:***

Rhinoceros 3D [4] is a three-dimensional modeling software that uses NURBS curves (Non-Uniform Rational B-Splines, a mathematical representation of 3D geometry [4]), which allows the user to create free-form surfaces and solids.

Rhinoceros has a plug-in for daylighting and energy simulation called DIVA [5]. This plug-in reads the 3D model created in Rhinoceros and asks the user to apply the materials to the model. It then runs the simulation for daylighting or thermal loads, according to what the user wants. DIVA also uses Energy Plus.

## Generative Design

'Generative design is not about designing a building.  
It's about designing the system that designs a building.'  
by Lars Hesselgren, Director of KPF Research (Stocking, 2009)



Generative Design (GD) is a process that produces various design solutions from a set of rules and constraints defined by algorithms. An algorithm is a mathematical description of an action that we want to perform. We can view them as a set of steps to follow in order to achieve a specific goal.

Algorithmic systems are the basis of GD, expressing, by a set of rules written in a specific language, the goals of the design, and the steps to achieve them. 'Thinking in terms of algorithms is a mapping process of design objectives onto step-by-step descriptions' (El-Khaldi, 2007). In this case, we are talking about computers understanding and performing actions defined by humans, and so the language used to communicate is necessarily a programming language, i.e., a methodical communication system to transmit a thought process to a machine (Leitão, et al., 2012).

In GD, a computational approach is used, creating functions that describe the design intent. The different values applied to the parameters of these functions are what allow them to create several design options, all with the same principles (Alfaris, 2009). GD is nowadays seen as a way to combine the creative mind of the architect with the effectiveness of modern technologies, thus leading to a more efficient work and to greater opportunities and different options of design (Fernandes, 2013).

GD started more connected to CAD tools. These tools are mainly used for representation purposes, as they only work with geometry, such as lines and solids, without giving them attributes, like the simple constructive difference between a wall and a slab. In terms of geometry, these two elements are just two parallelepipeds that happen to have different orientations in their spatial arrangement, i.e., walls are mainly vertical and slabs are mainly horizontal. With BIM tools, the paradigm shifts considerably. These tools consider the attributes of each constructive element, as well as their natural interdependence between each other. For example, one cannot design a window unless it is hosted in a wall, which changes the design methodology (Feist, et.al, 2016).

The application of GD to BIM tools is what interests us in this research, for it provides both the benefits of an algorithmic approach as well as the advantages of using a tool that works with all the constructive attributes of each building element.

### ***GD as a tool for energy analysis***

By associating a GD approach to an efficient evaluation system, architects can explore more design options which take into account the building's energy behavior, even in early stages of design.

When we want to run an energy analysis simulation, we provide the analysis tool with a 3D model, or a set of parameters that describe that same model, depending on the tool being used. Once we have the model described, the tool performs the energy analysis.

When using a traditional modeling approach, if we wanted to change some aspects of our building to try to improve energy consumption, we would have to manually introduce those changes, either on the 3D model or on the parameters that describe it. Either way, we would do this probably just a few times, comparing the results and choosing one option among two or three. Considering that each analysis simulation takes time to run and produce results, and that changing the model to test new options also takes time, we would spend several hours of work on each building variation.

Assuming a good knowledge of the modeling tools and good programming skills, the time spent on manually producing a building model can be close to the time spent on creating a set of algorithms to generate it. The big difference only comes afterwards, when it becomes necessary to change the model to generate variations of it. After having the model in the analysis software, the time that the simulation itself takes depends on the complexity of the model and on the settings defined in the software for the detailing of the analysis. When we run the first simulation, we evaluate the results and change the model according to the total energy consumption value given by the simulation. These changes can be easily made manually if the model isn't too complex but, usually, architects need to perform this kind of analysis in big and complex models. Changing a large and complex 3D model can take a lot of time, and this time increases considerably according

to the number of changes that the architect wants to make. On the other hand, GD can make the process of changing the model much faster. The architect just needs to adjust parameter values according to the changes needed, and run the program again to rapidly generate a new model.

## Using GD with Energy Performance Simulation Tools

### *The Case Study*

The building chosen as a case study for this research was Beirut Terraces, an habitational building in Lebanon, designed by Herzog & de Meuron. 'The building will comprise five different modular floor slabs used in varying combinations to create a mixture of overhangs and terraces' [6].

This modular concept creates a sense of randomness in the 25 residential floors of the building. The lower floors have more and smaller apartments, while the top floors have fewer and bigger ones. The main goal of this concept is to differentiate all the apartments available, creating 130 'living experiences', as described in the project's website [7]. In Figure 1 we can see some views of the existing building.



Figure 1. Beirut Terraces, by Herzog & de Meuron. Available in [www.beirutterraces.com](http://www.beirutterraces.com)

### *Modeling Strategy*

The generation of the model in Revit was made using Rosetta. Rosetta is a programming environment that connects front-end programming languages to back-end CAD/BIM applications (Lopes and Leitão, 2011). Through Rosetta, we were able to parametrize the model used as a case study and then perform the energy analysis using the same software as a back-end for both stages of the process. This was possible since the chosen software itself provides the tools needed to





perform the simulation. Revit and Insight 360 were used in this research as model generation and energy consumption simulation tools.

The building chosen as a case study for this approach was decomposed in its essential constructive elements to generate a simple model representative of its concept. The set of algorithms created has in mind the natural evolution of the architectural design, starting by evaluating the expected energy consumption of a building in its initial stage of design, and then performing more analysis along the way, promoting a sustainable design process. This way, architects can define their general concept and evaluate its different variations, choosing the one that achieves a better energy consumption, and then maintain this method throughout the whole design process.

We started by defining the basic elements that compose the essential form of the building. In this case, the building has 25 residential floors, and is divided in the following constructive elements: slabs, columns, core area, and walls.

Each slab has a shape that follows one of five different types. All of them are based on a square, but the edges have some breaks, forming polygons with 8, 10 or 12 edges, depending on the type of the slab.

When designing the model, we wanted to take advantage of GD to ensure that the randomness factor would be present, just like it was intended in the original design by Herzog & de Meuron. As we only had to write the script, instead of drawing each slab by hand or relying on a copy-paste process, we could easily make all the slabs different from each other. For the building to resemble its original form, we analyzed the five types of slabs in the plans provided by the architects in [7], and created a set of dimensional limits and constraints for each corner of the slab, thus producing numerous hypothesis from a single script. We used the same approach for the exterior walls, since they have the same behavior in terms of randomness. This way, we can increase the randomness of the model without the extra working hours that it would take with the traditional approach.

Another defining element of the building is the column arrangement, that has a specific pattern, continuous from the first to the top floor. For this element, we created a script to distribute the columns in the specific pattern intended and we used a specific column family provided by Revit. For elements like columns, we can import a family file, that allows us to choose from round columns, square columns, H-shaped columns, etc., or even create our own column and use it in the project.

Another important element is the core of the building, where we can find the staircases, the elevators, and the entrance foyers of each apartment. This area was considered as a unique area during an initial stage of the design, since it will have a very similar behavior in terms of energy consumption. This happens because these type of spaces are considered as non-heated spaces, due to being common areas outside of the apartments.

Regarding energy analysis, when inside an apartment we need to look at its limits. The interior walls that divide the various rooms are not designed to be isolators, only space separators. Thus, in an initial stage, and having in mind that we want glazed areas surrounding all the floors of the building, the impact on global energy analysis of the interior walls will be close to none. In a more advanced stage of the design, we should detail them, making it possible to compute the energy consumption of each apartment. As we are now focused on whole building energy consumption, this is not a main concern, and therefore the interior walls need not be considered and we only defined the glazed walls that separate the interior areas from the exterior.

This whole process allowed us to parametrically define every component of a simplified version of the building, making it very easy for us to change some aspects of the generated model by only modifying a few values in the code and waiting less than 20 seconds for the computer to generate the whole building with the new values.



## ***Energy Analysis Process***

For this research, we chose Autodesk Revit as a modeling tool, since we can generate the building using GD, through Rosetta, and then run the energy analysis simulation by sending the model to the online platform Autodesk Insight 360. In these tools, the energy analysis simulation is very simple to perform. Since Revit is a BIM tool, the materials are already applied to each constructive element and we only need to make sure that the thermal characteristics of the materials are active.

Then, we need to provide some additional information, like site, usage typology, and complexity of the simulation, e.g., whether it is a simple simulation using conceptual volumes, or a more complex simulation using building elements. Once the energy settings are defined and Revit produces the analytical surfaces, Revit can send the necessary information to Insight 360, which will perform the energy analysis. Once the analysis is complete, the architect can consult a report with information regarding the energy performance of the building.

For this research, we simplified the chosen building to its basic constructive elements, thus starting by analysing an initial stage of the concept and trying to understand the energy performance of the volume created. Because we are using GD, we can easily produce several variations of the same concept, by only changing a few values in the original script. This will help us considerably in the next stage of this research.

## ***Improvement Process***

Having the possibility of quickly generating a 3D model of the building in Revit (less than 20 seconds for each model), we can then start the improvement process.

On a first approach, we created a script to produce what we considered as a default stage of the building, considering this model the starting point for our analysis. Its dimensional constraints were defined having as base the original design proportions. The result will never be exactly the same as the original, as we are using random dimensions within specific intervals, instead of the actual dimensions of the existing project.

After having the model in Revit, the energy analysis is performed, the results read, and a new hypothesis tested. On a first glance, the typical architect cannot ascertain the exact elements that have an impact on the energy performance, and so a comparison phase is initiated.

We created ten different sets of values for the dimensional variations. This means that although the concept of the building will stay the same, as well as the number of floors and its composing elements, we changed the limit values for the variations of the slabs and exterior walls, since they are the elements that confer the sense of randomness in the building. By changing these values, we create new slabs and exterior walls, resulting in new living areas. We chose to compare the different generated buildings using the Energy Use Intensity (EUI) value, which represents the global energy used per square meter per year. A higher EUI value translates in greater energy consumption and greater economic costs. A lower EUI value means a lower energy demand and a more sustainable building. After running the energy analysis on the models, we chose the best performing one, i.e., the one with the lowest EUI value, as a starting point for the next step.

Then a second set of variations was created. This time we took the intervals of the best performing building of the first set and reduced the range of values in that interval. Whereas in the first set, the decision of values was random, in the second set, the values were analyzed and restricted. Once again, we took the best performing one, and chose that to continue this process. In the third set of variations, only five models were created, to adjust some values in order to improve the building's consistency.

Besides changing the limit values that defined the variations of slabs and exterior walls, we opted to test three other components, which we considered would affect whole building energy consumption, and therefore could contribute to the improvement of our model. One of the options tested was the rotation of the building. Since the plot available is a square with approximately the

same dimensions as the building, we only had three possible variations. None of these variations contributed to a better energy performance. We also changed the dimensions of the core area, where one of the options contributed to a better energy performance. One other variation was the height of each floor. Figure 2 shows the results obtained.

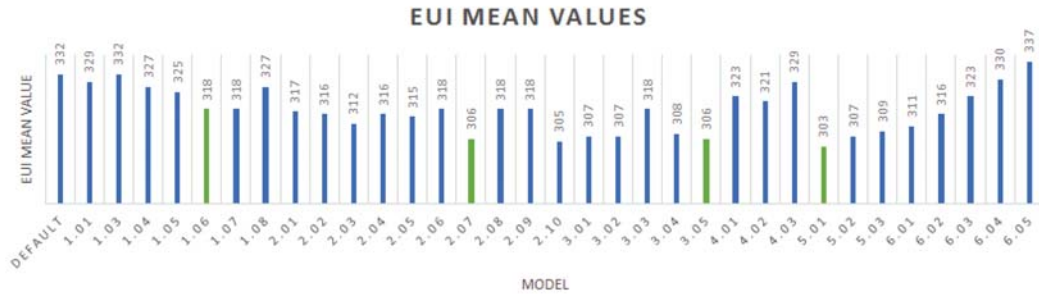

Figure 2. EUI mean values resulting from the energy analysis performed using Autodesk Insight 360, connected to Autodesk Revit 2017.

As we can see in Figure 2, the green bars represent the models chosen to continue on to the next set. The first three bars indicate the evolution of the first three tests described. As these three were a continuation of each other, progressively improving the model, they appear in a chronological order. The other three variations proposed were applied without a specific order. After applying them, we concluded that the best performing model (model “5.01”) among the ones tested, had no need for rotation of the building or variation of the height of the floors, but benefited from the variation of the dimensions of the core area. In Figure 3, we see the model resulting from this process, which corresponds to model “5.01”.

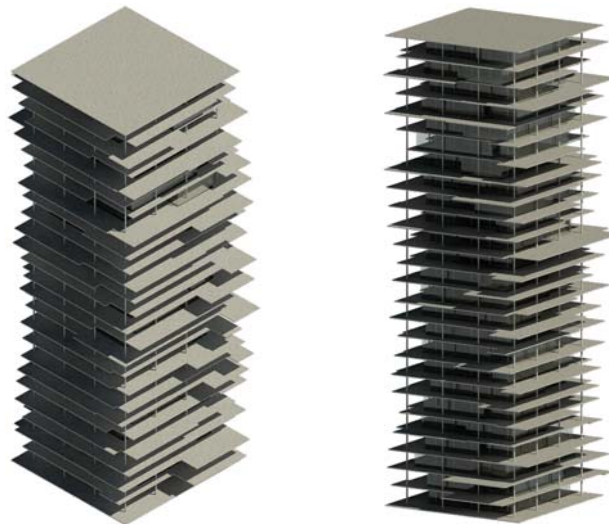

Figure 3. Model “5.01”, produced in Autodesk Revit 2017. Different views.



## Conclusions and Future Work

Energy analysis tools are increasingly important in Architecture and Generative Design allows us to automate their use, reducing time and effort and greatly expanding the design options available to the architect.

Using energy analysis tools in early stages of the design process helps improve sustainable architecture, as energy consumption concerns start at the beginning of the design and not only at the end, where the energy analysis is nowadays typically done.

In this work, we took the principle of genetic evolution and applied it to our model, creating the variations by hand. This process was already made faster by the use of GD, as it took less than 20 seconds for each model to be generated, instead of doing all the changes in the model by hand. To automate the process even further, we can use a Genetic Algorithm, an evolutive procedure based on the Darwinian notion of 'the survival of the fittest' (Caldas, et al., 2002), by defining the EUI value as the objective to be achieved (in this case, the smallest EUI value possible).

As future work we are planning to develop an automatic optimization tool, improving the presented workflow and taking it further. We can already see some examples of optimization being applied, like Asl (2013), who proposes an optimization tool that uses Autodesk Revit and Autodesk Green Building Studio (recently updated to Insight 360), generating alternative options in BIM and automatically performing energy simulations, giving as a result the optimal solution found between the ones tested. This work uses file exportation to send the model from Revit to Green Building Studio, and then again back to Revit, providing the results via CSV (comma-separated values) files. It receives the parameters that are allowed to change and generates Green Building Studio gbXML files to be analyzed. This work was used to improve window dimensions in a two storey house.

The goal is to take this further, since we want to change several parameters in different elements and in different stages of the design. For example, in the case study presented in our research, we improved whole building energy consumption but, in the future, we plan to reach a stage where we also optimize the interior divisions, creating a better distribution of apartments.

## Acknowledgements

This work was supported by national funds through Fundação para a Ciência e a Tecnologia (FCT) with reference UID/CEC/50021/2013.

## References

- Alfaris, A., *Emergence Through Conflict The Multi-Disciplinary Design System (MDDS)*, Ph.D. dissertation, 2009.
- Asl, M. R. and Zarrinmehr, S., "Towards Bim-based Parametric Building Energy Performance Optimization", *Adaptive Architecture, Proceedings of the 33st Annual Conference of the Association for Computer Aided Design in Architecture, ACADIA 2013*, pp. 101–108, 2013.
- Caldas, L. G. and Norford, L. K., "A design optimization tool based on a genetic algorithm", *Automation in Construction*, vol. 11, no. 2, pp. 173–184, 2002.
- El-Khaldi, M., *Mapping Boundaries of Generative Systems for Design Synthesis*, Ph.D. dissertation, 2007.
- Feist, S., Barreto, G., Ferreira, B. and Leitão, A., "Portable Generative Design for Building Information Modelling", *Living Systems and Micro-Utopias: Towards Continuous Designing*,



Proceedings of the 21st International Conference of the Association for Computer-Aided Architectural Design Research in Asia CAADRIA 2016, pp. 147–156, 2016.

Fernandes, R., *Generative Design: a new stage in the design process*, M.Sc. dissertation, 2013.

Leitão, A., Santos, L. and Lopes, J., “Programming Languages For Generative Design: A Comparative Study”. *International Journal of Architectural Computing*, vol. 10, issue. 1, pp. 139-162, 2012

Lopes, J. and Leitão, A., “Portable generative design for CAD applications,” *Integration Through Computation, Proceedings of the 31st Annual Conference of the Association for Computer Aided Design in Architecture, ACADIA 2011*, pp. 196–203, 2011.

Stocking, A. W., *Generative Design Is Changing the Face of Architecture*, 2009.

[1] [www.iea.org/topics/energyefficiency](http://www.iea.org/topics/energyefficiency).

[2] [www.insight360.autodesk.com](http://www.insight360.autodesk.com).

[3] [www.autodesk.com/products/revit-family/overview](http://www.autodesk.com/products/revit-family/overview).

[4] [www.rhino3d.com](http://www.rhino3d.com).

[5] [www.diva4rhino.com](http://www.diva4rhino.com).

[6] [www.dezeen.com/2010/07/27/beirut-terraces-by-herzog-de-meuron](http://www.dezeen.com/2010/07/27/beirut-terraces-by-herzog-de-meuron).

[7] [www.beirutterraces.com](http://www.beirutterraces.com).





A psychotropic surface based on soft shape changing material:  
Emotional input and pneumatically driven actuator  
Yann Blanchi, Elizabeth Mortamais

## A psychotropic surface based on soft shape changing material

### Emotional input and pneumatically driven actuator

Yann Blanchi<sup>1</sup>, Elizabeth Mortamais<sup>2</sup>

<sup>1, 2</sup>*EVCAU laboratory School of Architecture, Paris Val de Seine, France*

<sup>1</sup>*yann.blanchi@paris-valdeseine.archi.fr,*

<sup>2</sup>*elizabeth.mortamais@paris-valdeseine.archi.fr*

**Abstract.** We are considering realizing a prototype of adaptive architecture based on an example from a science fiction novel by JG Ballard. We analyse this short story with an interaction designer's point of view. Psychotropic houses in the novel are based on feel data and shape changing interface. We study these two characteristics as components of an open feedback loop system linking inhabitants and his environment. We show how emotions can be included in the design process; and how soft architecture crossing soft robotic can create a pneumatically driven actuator. This allows us to precise the goals, the operating principle, the first tests and the specifications of our prototype.

**Keywords.** Adaptive architecture; Psychotropic surface; Emotional input; Pneumatically driven actuator; Soft Changing Interface

## Introduction

The psychotropic house expression comes from the science fiction novel "The Thousand Dreams of Stellavista", written by J.G. Ballard and published by Amazing Fact and Science Fiction in 1962. In Vermillon Sands town all the houses are psychotropic. They are designed to sense the psychological state of their owners. The rooms' surfaces (wall, floor, ceiling) change and move according to the users feeling. They are made of "plastex", a shape changing material, composed with a combination of plaster and latex. The surfaces softly transform themselves, stretch and retract in order to reflect the inhabitant personality with a memory feedback. The rooms' surfaces function as interfaces in which material is involved in real time shape changing. The motivation of our study is to design, fabricate and evaluate an interactive prototype in the context of adaptive architecture. We consider emotion as inputs and we implement pneumatically driven actuators. This prototyping is a part of a PhD research. In order to situate our research we purpose in this paper a selected state of the art going through three main topics, the emotional data process, the soft shape changing material and we start with a definition of the Adaptive Architecture concept and specifications of the psychotropic house coming from Ballard's novel.

## Adaptive Architecture

### Definition and framework

From the dictionary, « adaptation » means the action to adapt or the result of this action. Adaptation is also a process of adjusting to new conditions in order to suit to the context or to the users. Moreover the adaptive concept supposes an idea of connection and it means the ability to generate an action. Regarding this definition an adaptive architecture could be an architecture that support an active process, linking the building with the environment and the inhabitants. An architecture that is able to change in a dynamic way. The intent is to conceive more efficient architecture in the



context of environment and uses changing. Cedric Price was the first to conceptualize real adaptive environment that could physically move and respond to changing programmatic and environmental conditions (Kretzer, 2014), he worked closely with cyberneticist like Gordon Pask and John Frazer. Since a few years three international conferences or symposiums dealt with this topic and gather the cutting edge works of the field: In march 2011, the International Adaptive Architecture Conference was held in London; two years later the 33rd Annual Conference ACADIA with the title Adaptive Architecture (Beesley, 2013) focused on the computational design of environmentally responsive, intelligent, interactive, and reconfigurable architecture; in 2013, Alive symposium (Kretzer, 2014) questioned the interrelations between architecture and nature.

### ***Ballard's psychotropic house***

The term "psychotropic house" comes from the dystopian vision of J.G. Ballard's short story, *The Thousand Dreams of Stellavista*, published by Amazing Fact and Science Fiction in 1962. In Vermillion Sands town all the houses are psychotropic. In a world of psychotropic houses, the very walls respond to the emotions of those who live (and lived) in them. Living in this house style can become frightening or dangerous. Throughout his science fiction short story, Ballard gives us the psychotropic (PT) house description. Beyond the dystrophic vision of Ballard, we re-read this science fiction short with an interaction designer (IxD) point of view. We can identify the Ballard's PT houses as an adaptive process. As biology sciences and information sciences understood adaptivity, this process includes a regulatory system with a stimulus-response coupling mechanism. It's an open feedback loop with three main components: the stimuli, the control system and the response. We summarize them as follows.

- The PT houses are sensitive to different **stimuli** resulting from its inhabitant's behavior. The rooms' surfaces (wall, floor, ceiling) change and move according to the users feeling. They are designed to sense the psychological state of their owners. The psychic orientation of the owner thus conferred a kind of building pedigree. The occupant presence, thus his psychological and physiological characteristics is captured in real time by the house. The positions of the occupant, his movements, mood changes, breathing rhythm and heartbeat are captured by many senso-cells distributed over the surfaces.
- The **control system** is able to steer the PT houses. Inhabitants can switch on-off the control console to activate the system. The PT house moves from the static state to a dynamic state. The house responses intensity is adjustable according to three modes: low, medium and full. The sensibility is chosen for the inhabitant desires and his ability to coexist with the system. In addition, the system has memory. Ballard proceeds by anthropomorphic analogy by comparing the house to a human brain. Past events stored in the memory, can re-emerge in the present and interfere with the house real-time reactions. The control system is assimilated to a psychic process. The machine behavior becomes uncontrollable and the story turns to drama. With Ballard, we find the same dystopian vision of artificial intelligence as in "2001: A Space Odyssey " (Arthur C. Clarke) with the HAL 9000 supercomputer failure.
- The PT Houses are dynamic and can move themselves. They have a range of possible **responses** to stimuli. The houses are made of "plastex", a shape changing material, composed with a combination of plaster and latex. They are built with elastic modules, retracting or expanding according to the control system. Modules can rotate on themselves, have spasms or purrs, balconies tip over in burglar presence. Ceilings can go down by themselves, walls transform into a seat matching with the body and entrance can be deployed welcoming his host. Shape-changing surfaces allow for morphological and dimensional variations, while the materials intrinsic properties make it possible to modify the surface opacity, color or texture.



A psychotropic surface based on soft shape changing material:  
Emotional input and pneumatically driven actuator  
Yann Blanchi, Elizabeth Mortamais

## Feel data

One of the PT house specificity is its ability to capture the emotion state of the inhabitants. Nowadays its possible to collect these information's and to use them as process input. Encoded cerebral activity can permit invalid person to control objects. Inhabitant and his living environment could be linked in an interactive brain activity based system?

### *Emotional input*

Emotions are a polysemous concept, and according to Pluchick, it is the most confusing chapter of psychology, actually this concept has more than 90 definitions (Pluchik, 2001). Therefore far from exhaustively, we only note the following points that interest our work. From an etymological point of view, "emotion" comes from the Latin "motio" meaning: movement, trouble, thrill. According to evolutionary psychology, emotions could be a behavioral phenomenon, an adaptive capacity, in response to an external or internal stimulus, an internal state change with communicative value. If emotions are a mixture of biochemical, sociocultural and neurological factors, their translations are both cognitive and bodily. We are aware of the partial and debatable dimension of this type of measure, it is obvious that the data fallibility in input is essential to process in its totality. However we emphasize in this article the informational chain between the user and the architecture, the way they create a system. Data accuracy will be the subject of further work. We here identify three methods for emotions capture: Physiological measurements, facial expression and brain activity.

- To estimate users' emotional state, the **facial expression** analysis is done by image and video. The Face Action Encoding System (FACS) is a method of describing facial movements developed by the psychologists Paul Ekman and Wallace Friesen in 1978. The face-coded movements are then connected to primary or secondary emotion categories. Emotional Sciences are used for emotional man-machine intelligent system, where emotion data links the user to the computer. Marketing has seized feel data, and tracks the consumer emotions for commercial purposes, with all the ethical questions that these issues are arising.
- The Schnore work in 1995 is based on the emotion measurements by **physiological indicators** as heart rate, blood pressure, skin conductance, respiratory rate, and water temperature. See the Emotional Cartography by Christian Nold, where bio-sensor measures changes in the sweat level of the wearers' fingers based. A second example comes from the Nano-technologies research: ANR project SWEAT (Sweatband for physiological security of Workers wearing protective Equipment by an Analysis using biochemical Tools). The project purposes to measure the firefighter stress during the intervention by means of physiological sensors inserted in the sock fabric.
- Mind Brain Computer Interface (MBCI) permits a device mind control from the user. It's possible by measuring the brain activity and issue to commands a computer system. Initially assisting handicapped people motivated these researchers. The research field has been extended to the smart home (Kosmyrna, 2016). The Hybrid research team, in Rennes (France), studies interactive systems that reacted with body and mind inputs. The researchers test the feasibility of MBCI in a realistic smart home environment. These works open new kind of interaction between inhabitants and buildings. Using electroencephalography, neuroscience had shown that cortical activation is associated to user thinking's object.



Data driven process encodes data collected from the environment and users, into information and knowledge. It employs them into the architectural production with generative or materialization purposes. Real time data includes a dynamic between environment and designs. The architect becomes the designer of a process and not (only) a result (Oxman, 2013).

## Soft shape changing material

### *Inflatable structures*

Inflatable structures are essentially ambivalent. At first coming from the American military applications in the first part of the twentieth century, they are booming in hippy utopian circles of the seventies by becoming an ephemeral joyful symbol (Tenret, 2000). We consider here well-known structure originality: It is dynamic and not static, it can inflate or deflate. This mechanical duality is inflatable structure characteristic; It allows us to define them as a family of structures whose constitution involves: on the one hand, one or more enclosures, generally closed and non-rigid; on the other hand, the fluid action is causing pressure differences delimited by these enclosures and generating the structure shape and stability (Aubert, 1968). The flexibility and lightness properties are the essential enclosures characteristics to respond to mechanical, physical and chemical stresses. Two materials types are used: homogeneous deformable and substantially elastic materials such as plastic or rubber sheets; and flexible and inextensible heterogeneous materials, such as coated fabrics. For their part, the fluids used to exert pressure on the inflatable structure enclosures can be compressible or incompressible, respectively generating deformable or non-deformable structures. Inflatables structures are also well known for its generous scale to material proportion (Baranovskaya, 2016). According to Negroponte soft materials, like inflatable plastics, are presently the most natural material for responsive architecture, because they exhibit motor reflexes through simple control (Negroponte, 1976). He focuses particularly on cellular inflatable structures, which could have pressure-sensing devices in each pneumatic cell. This makes it possible to have structure respond locally to body movements and interactions.

### *Soft robotic*

Robotics defines robots as controlled and programmed machines. Specifically, soft robotics is defined as machine made of soft-often elastomeric-materials, or machines composed of multiple hard-robotic actuators that operate in concert, and demonstrate soft-robot-like properties (Ilievski, 2011). This approach breaks the fundamental assumption that the robot is exclusively a kinematic chain of rigid links. Soft robots are able to handling fragile objects without damage and to moving across unknown, irregular, and shifting terrain. The Mc Kibben pneumatic actuator was an air muscle invented for orthotics in the fifty's years: they consist of a bladder covered in a shell of braided, strong, inextensible fibers. The use of soft materials with fluids in it, allows for continuous deformation. Recently the robotic researchers have explored scalable methods for gripping and manipulating objects at the micro and nano scales with pneumatic network (Pneunet). Pneumatically driven Flexible Microactuators (FMAs) showed their bending, gripping, and manipulating objects capabilities (Ilievski, 2011). Air has low viscosity and permits rapid actuation; these properties are useful for designing real-time interactions. Furthermore a pneumatic surface affords a direct interaction, merging input and output interactions, and provides a haptic feedback. This property is well known in the soft robotic. Thus the soft pneumatically actuated interface distributes the force over the entire area of contact.



A psychotropic surface based on soft shape changing material:  
Emotional input and pneumatically driven actuator  
Yann Blanchi, Elizabeth Mortamais

## **Shape changing interface (SCI)**

Simultaneously, material-based interface design and Shape-Change Interfaces (SCI) are emerging topics (Rasmussen, 2012). The authors base their review on a selection of 44 papers on SCI. According to them, currently, the main SCI goal is the information communication, but it can also provide dynamic affordances or haptic feedback. As Pouvyrev noted “The coupling between tangible and digital has usually been in one direction; we can change digital information through physical handles, but the digital world has no effect on tangible interface elements”. It’s permit by the development of new actuator technologies, microprocessors, and smart materials (Poupyrev, 2007). A SCI uses physical change of shape as input or output. Here we focus on actuation, which change in surface texture, visible or perceived by touch. Self-actuated change and shape is the SCI main property and places SCIs in the robots category. Ramussen suggests three main categories for analyze SCI: shape change type, transformation type and process of interaction (Ramussen, 2012). The types of shape change are most of the time topologically equivalent and reversible. Velocity, path and direction constitute the kinetic parameter of the transformation. Three approaches of interact are possible: no-interaction, indirect interaction and direct interaction. Shape changing is thus output only, or input and output with close or remote sensitivity. For example the “Muscle Projet” by Oosterhuis and Biloría suggests and provokes the possibilities of engaging with space and to break the building façade stereotype as a barrier separating the interior and exterior environment.

## **Pneumatically driven actuator**

Beyond applications in soft robotics, pneumatically driven soft shape changing materials have recently been introduced to HCI as Shape Changing Interfaces with the PneuUI projet (Yao, 2013). The authors have presented various types of shape-changing interface enabled by pneumatic soft composite materials. By introducing constraints through materials with pre-programmed structures, they can design and control the direction, location and angle of deformation. They also identified and tested shape-changing primitives at the macro and micro level, including curvature change of surfaces. More recently AeroMorph project (Ou, 2016) also tests methods to design, simulate, and fabricate transforming inflatable structures with various materials. The group developed a software tool that simulates this bending mechanism for a given geometry, simulates its transformation, and exports the compound geometry as digital fabrication files. The experiment shows the importance of geometry design in the moving process of SCI. Tessellation and origami are keys for designing surfaces that can be deformed. Furthermore parametric software and digital fabrication enable non-standard display and non-uniform patterns specifically adapted to the data variation.

## **Experimental protocol**

### **Prototype goals**

The purpose of the experimentation is to evaluate the feasibility of a psychotropic surface based on soft shape changing material. The idea is to build an architecture that takes care of its inhabitants, a benevolent or caring architecture, but also that the inhabitants have an active role toward their built environment. The experimentation hypothesis is that the inhabitant could interact with a soft device. Emotional input and pneumatically driven actuator could be linked by an informational control system, and could create an efficient adaptive architecture. The operating principle is an open loop including a positive feedback. The system purpose an interrelations between inhabitant and soft surface, the components work together to achieve a mutual adaptive objective in a positive way as well as possible (of course no drama as in Ballard’s Vermillion Sands town).

## Prototype operating principle

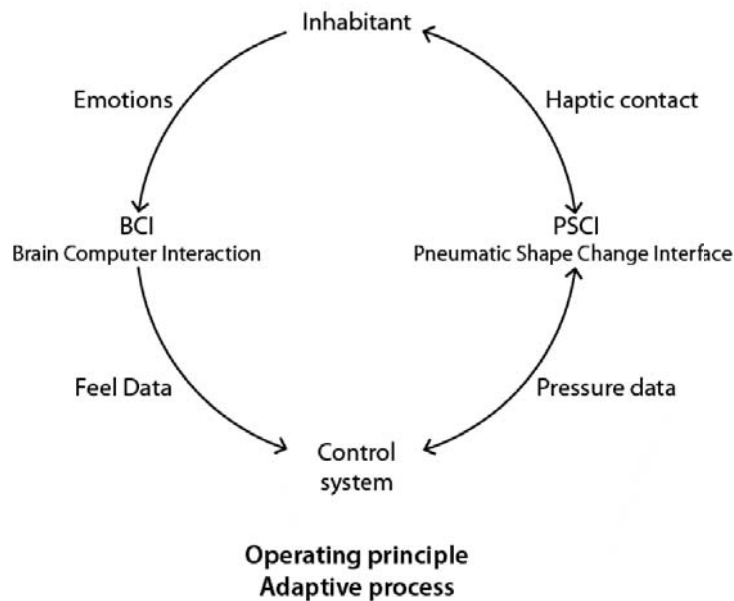

## Prototype first tests

Before making our prototype we will carry out a series of preliminary tests.

- Relationship between use scenarios and algorithms
- Relationship between the inflatable geometry and its deformation.
- Relationship between the inflatable cell scale and the reaction time of the inflation

## Prototype specifications

In order to fabricate our prototype, we plan to combine different technological building blocks, and we have identified the following components:

- Brain Control Interface (BCI): Wireless electroencephalogram (EEG) + Analysis EEG software. The most familiar classification uses EEG waveform frequency (eg, alpha, beta, theta, and delta), amplitude, and location.
- Pneuduino is a toolkit for controlling airflow and pressure to design robots developed by Felix Heibeck, Jifei Ou at MIT Media Lab, Tangible Media Group.
- Shape Change Interface (SCI): Silicone rubbers cast in complex; multipart molds produced using 3-D printers (Soft robotic toolkit web).

## Conclusions

In this paper we have defined adaptive architecture using the Ballard's novel example. Feel data and shape change interface had been explored as sensor and actuator in an open feedback loop system. To specify our experimentation goals, we chose the emotional input and the pneumatically driven actuator. They had been included in prototype operating principle. The prototype will test the psychotropic surface efficiency in the adaptive architecture framework. The





A psychotropic surface based on soft shape changing material:  
Emotional input and pneumatically driven actuator  
Yann Blanche, Elizabeth Mortamais

theoretical framework thus specified, let us begin the practical part of our research. The use scenarios and the control system have to be test at first. We expect with the research to show that architecture could become a kinematic chain of soft links, leaving the static world to get closer to the dynamics of the living world.

## References:

Aubert, J, Structures gonflables, Catalogue de l'exposition, mars 1968, ARC, Musée d'art moderne de la ville de Paris, 1968.

Baranovskaya, Y, Pneumatically Activated Preprogrammed Knitted Textiles, eCAADe 34, 2016.

Beesley, Ph., Khan, O., Stacey, M., ACADIA 13: Adaptive Architecture, Proceedings of the 33rd Annual Conference of the Association for Computer Aided Design in Architecture (ACADIA) ISBN 978-1-926724-22-5, Cambridge 24-26 October, 2013

Ilievski F., Mazzeo A.M., Shepherd R.F., Chen X., and Whitesides G.M. Soft Robotics for Chemists. *Angew. Chem. Int. Ed.* 2011, 50, 1890 –1895

Kretzer, Manuel, *Alive: Advancements in Adaptive Architecture (Applied Virtuality Book Series)*, 2013.

Kosmyna N, Tarpin-Bernard F, Bonnefond N and Rivet B. Feasibility of BCI Control in a Realistic Smart Home Environment. *Front. Hum. Neurosci.* 10:416

Negroponte, N. *Soft Architecture Machines*. MIT Press, 1976.

Ou J., Skouras M., Vlavianos N., Heibeck F., Cheng CY., Peters J., Ishii H. *aeroMorph - Heat-sealing Inflatable Shape-change Materials for Interaction Design*. UIST '16 Proceedings of the 29th Annual Symposium on User Interface Software and Technology.

Oxman, R. & Oxman, R. (2013) *Theories of the Digital in Architecture*. Routledge,

Plutchik, R. *Emotions and Life: Perspectives from Psychology, Biology, and Evolution* by Robert Plutchik, American Psychological Association (APA), 2001.

Poupyrev, I.; Nashida, T. & Okabe, M. Actuation and tangible user interfaces: the Vaucanson duck, robots, and shape displays., in Brygg Ullmer & Albrecht Schmidt, ed., 'Tangible and Embedded Interaction' , ACM, , pp. 205-212, 2007.

Rasmussen, M. K., Pedersen, E. W., Petersen, M. G., & Hornbæk, K. *Shape-Changing Interfaces: A Review of the Design Space and Open Research Questions*. CHI 2012

Tenret, Y, *Air-Air – Celebrating inflatables*, Les Presses du Réel, Grimaldi Forum éditeur, Monaco, 2000.

Yao, L., Niiyama, R., Ou, J., Follmer, S., Della Silva, C., and Ishii, H. *Pneui: Pneumatically actuated soft composite materials for shape changing interfaces*. In Proceedings of the 26th Annual ACM Symposium on User Interface Software and Technology, UIST '13, ACM (New York, NY, USA, 2013), 13–22.



## The impact of digital fabrication in contemporary Portuguese architecture

### Witnessing four practical cases

Susana Neves<sup>1</sup>, José Beirão<sup>2</sup>, João Rocha<sup>3</sup>.

<sup>1</sup>LPR, Faculty of Architecture, University of Lisbon, PORTUGAL, <sup>2</sup>CIAUD, Faculty of Architecture, University of Lisbon PORTUGAL, <sup>3</sup>University of Évora PORTUGAL

<sup>1</sup>fonsecaneves.susana@gmail.com, <sup>2</sup>jnb@fa.ulisboa.pt, <sup>3</sup>rjoao@uevora.pt

**Abstract.** The use of digital fabrication tools in Portuguese architecture is a very recent approach and it is still making its first steps. With an experimental character at the beginning, allied with the industry or with the academic environment, today the use of digital fabrication starts to gain impact in Portuguese architecture and is beginning to answer the growing market demand for “mass customization” (Mitchell, 2001).

This research focuses on understanding the current context and connection of digital fabrication in Portuguese architecture until today, based on the professional path of four Portuguese architects using digital fabrication in different approaches.

**Keywords.** Digital fabrication; Architecture; Portugal.

## Introduction

Architecture today faces a constantly challenging panorama. In Portugal, emblematic buildings that at some point resorted to digital manufacturing to reach the end result, are emerging.

Considering the concept that the design process connects ideation and form finding (Computer Aided Design - CAD), development and performance (Computer Aided Engineering - CAE) and fabrication (Computing Aided Manufacturing - CAM) as a network to exchange information (Sousa, 2005), the use of computers allow more complex geometries that bring up new challenges of "constructability", allied with the fact that digital fabrication is possible because machines have a computer numerically controlled (CNC) process. These notions together allow the architect to understand what "instruments of practice are needed" to achieve the geometries created, without questioning if it is buildable (Branko Kolarevic, 2003). In this research digital fabrication will be considered as an option that was considered in the architectural design process either for producing a scaled model of the project, a 1:1 prototype, or to produce the building or parts of it.

Computer Numerical Control (CNC) machines were created in the air craft industry in the 1940's and later developed at Massachusetts Institute of Technology (MIT) which presented it to the market in 1952. This allows controlling the mechanical actions of an equipment using a programmable code with alphanumeric data that represents the relative positions between a workhead (tool) and a workpart (material). (Groover, 1996) The tools used by the machines and the way they transform the material divide digital fabrication in three processes: additive - 3D printing, subtractive - laser cutting or milling, and (de)formative -folding metal. (Sousa, 2010) Some of these processes imply assembly afterwards either manually or digital using robots.

The moment that the Portuguese architecture begun to be more widely accepted in relation to these tools matches, essentially, with the time when they became accessible to the public, mainly through the appearance of the FabLab program (Gershenfeld, 2007 and 2012). Even though, this program appears in Portugal in 2012 (COMPETE, 2012), the potential of this technology was



already used by laboratories in academia, which in turn generated, over the years, small research centers linked to the main universities of the country. Some focused on research, often with a direct connection to industry and others, using the original philosophy of the program: open to the public and with partnerships with companies and industry.

When digital fabrication increased the proximity to the general public, through the FabLabs, these spaces allowed anyone to put new ideas into practice for the simple fact that it was possible to produce them. Emerging in specific programs associated with local entities or inside business hubs, these labs give a strong contribution to the local communities, and in many cases, partnerships with local schools, with presence in several levels of education; these are also harbors where creative subjects from artistic or technological areas, among others, could find a collaborative work environment and knowledge exchange. (Lisboa, 2013)

Young architects, as creatives, trying to find their way into an increasingly competitive market, are gradually exploring this process for the possibilities of digital prototyping, testing (even on a 1:1 scale) and repeating the process until the final product is ready. The tendency of using this kind of resources in architecture can be found in environments like offices that value research and academic laboratories that have a strong connection with the industry and young architects that use open places like FabLabs to explore, experiment and create new lines and approaches to construction.

Digital fabrication is becoming patent within an emerging group of Portuguese architects. This research aims at understanding their motivations and purposes in the use of digital fabrication in Architecture. Since when do Portuguese Architects resort consciously and purposely to digital techniques from ideation to fabrication? Who are they? And what are they doing? What are their motivations and expectations? For that, four professionals with special relevance in the application of digital prototyping within the Portuguese architecture were chosen and interviewed, regarding a specific part of their work:

- Professor José Pedro Sousa, teacher at the Faculty of Architecture of the University of Porto (FAUP), coordinator of the Digital Fabrication Laboratory (DFL), former architect and co-founder of ReD - Research and Design and former member and co-founder of Oporto Laboratory for architecture and Design (OPO-Lab), was chosen for the research work done in DFL using a robotic arm.
- Rafael Calado, coordinator of Lisbon FabLab (FabLab Lisboa) and project coordinator at Lisbon's council, for his work in FabLab Lisboa and the way he encourages the network of people and spaces that want to produce and experiment ideas.
- Pedro Campos Costa, founder of Campos Costa architects, an architecture office that in their projects apply the philosophy that research can bring new approaches and contributions for the buildings.
- Ana Fonseca, co-founder of DigitaLab, an office that was born with experimenting projects and is now making its mark on using a digital process (from idea to production) on the way space can be felt.

## Digital Fabrication in Portuguese architecture

Digital fabrication is connected with a design process made in a digital environment.

Historically, after the industrial revolution (end of XIX and beginning of the XX centuries) where the architecture was standardized and resorted to mass production techniques, the introduction of CNC machines and computers, in the decades of 60 and 70, generated an enormous change in the way architecture and engineering problems are represented, developed and solved, as we can see in Sidney's Opera House (1959-1973). In the last four decades of the XX century, with the advent of Computer Aided Design (CAD) the architects started to translate the drawings made by hand into to the computer to make the information more accurate, but when the geometries started



to get more complicated there was a gap, between design ideas allowed by the new representation tools and the possibilities of the construction media. The beginning of the XXI century is marked with the need to reestablish the connection between architecture, engineering and industry (manufacture). (Oliveira, 2014)

With the computer, the architect today, is able to control simple and complex geometry (CAD) as well as inform them by the use of Building Information Modelling (BIM), engineers can simulate the efficiency of the building through Computer Aided Engineering (CAE) and using Computer Aided Manufacturing (CAM) it is possible to be closer to the industrial process. The design process is a network of information. However, the connection of design ideation to manufacture and efficiency of the manufacture technologies seem to have still a long way to go and have had the perverse effect of keeping many architects closer to the traditional construction practices.

Frank Gehry was the pioneer on using digital fabrication in his buildings like the Peix d'Or (1992), in Barcelona and the Guggenheim Museum (1997), in Bilbao, both in Spain, or the Stata Center (2004), in Cambridge, USA, that open to the public in 2004. In these buildings the need to make something out of the standard took him to approach industry able to use digital fabrication to achieve a personalized solution for his buildings.

In Portugal digital fabrication, as a conscious design attitude, started to take its first steps in architecture inside an academic environment, back in 2005, with the assembly of the ISTAR Labs at Instituto Superior Técnico (IST) part of the University of Lisbon, where José Pinto Duarte has created a digital fabrication laboratory in 2007, mostly with resources that were spread all over the campus, but with the lab they created a space where the technology was also accessible to the architecture students. (Duarte, 2007) One of the students attending classes there, then as PhD student, was José Pedro Sousa, that 5 years later co-found with João Barata Feio the Oporto Laboratory for architecture and Design (OPO-Lab). The first space in the country where the philosophy of the FabLab was starting to appear.

One year later, the FabLab EDP in Lisbon opened to the public following the FabLab program from MIT, becoming the first in the country. In the next years, other spaces started to emerge like the Vitruvius FabLab (2012) open to the public, but since it is inside University Institute of Lisbon (ISCTE-IUL) it is also connected with the research field. In the following year FabLab Lisboa opens its doors, making a mark in the local community as well as in the network of the community of "makers" (Maker, 2004) all over Lisbon's surroundings. The philosophy of a collaborative space with democratized knowledge and access to machinery once just accessible to the industry was the base of these spaces and others that are still opening all over the country each one adding more knowledge and innovation.

In the academia it was in the north of the country, in 2014, that the Digital Fabrication Laboratory (DFL) in the Faculty of Architecture in Porto (FAUP) brought the biggest change in architecture research through the experimentation with a robotic arm and with a selected network of partnerships.

## Through the eyes of four architects

Considering that in the Portuguese context there is still no application of digital fabrication in the construction of a complete building the examples presented here will be focusing on the main advantage that digital fabrication offers: customization. It is necessary to consider who and how digital fabrication in Portuguese architecture is been used, the needs that led to this, the difficulties and advantages that emerged throughout the process. Understanding the national panorama will allow to create an updated context, to know the technologies that are being made available, to learn from what has been done and to generate new possibilities and uses for the future.

Regarding the presence of digital fabrication in Portugal, there are four main areas that will be considered in this study: the academic field at a research level, the FabLab where learning comes



from doing, and the professional level where digital fabrication is connected with the industry and can be applied at two levels -the outside and inside of the building.

### ***The case studies***

For the academic field, using digital fabrication in architecture, DFL [Figure 1] was chosen for being a "research group committed to developing advanced research work in the fields of Design, Material and Fabrication innovation". Its coordinator is Professor José Pedro Sousa. (Laboratory, 2013)

The space has a room dedicated to the robotic arm, a workshop, rooms for classes and exhibit and the design office. The available technology there is: a robotic arm (Kuka KR120 HA r2700, with a payload of 120Kg and a radius range of 2.700 mm), a 3D printer (Makerbot – Replicator 2x Dual head extrusion in ABS / PLA Printing, volume: 25x15x15cm) and a vinyl cutter (Silhouette CAMEO, cutting width: 300mm, cutting length: 600mm).

The Corkcrete Arch [Figure 2] is an example of the connection of this laboratory with the industry and work develop by its research team. The aim of this project was to use "robotic fabrication technologies in the production of a novel building system", through materials like concrete for the structure and as covering cork, for its thermal and acoustic properties, it was possible to achieve a result that was easily pre-fabricated and even manually assembled. (DFL, 2016)



Figure 1. DFL space: image on the left - Professor José Pedro Sousa explaining how to maneuver the robotic arm; image on the right - The robotic arm with a tool prepared to mill.





Figure 2. Corkcrete Arch (Photography by DFL).

In the FabLab context, although the network in Portugal is getting bigger every day, the FabLab Lisboa [Figure 3] in the center of the capital of the country was selected for its presence in several subjects and the way it reinforces the maker's community.

The space has a room for the milling machine, an office, an open space with zones for workshop, 3D printing and electronics, and next to it there is a space reserved for makers that in the search of new product. The technologies available are: laser cutting (GCC Mercury III 60W, size 635x458mm), milling machine (OUPLAN 2015, size 2000x1500x150mm), 3D printer (Ultimaker Original, size 20.5x20.5x20 cm), precision milling machine (ROLAND Modela MDX-20, size 203.2x152.4x55mm), 3D scanner (MICROSOFT KINECT), vinyl cutter (Silhouette Cameo, size 305x3000x8mm), hot wire cutter (Proxxon Thermocut 230, size 440x335x115mm) and a metal lathe.



Figure 3. FabLab Lisboa space.(Photography by FabLab Lisboa).

At the building scale, when the need to customize a specific part of the building is a crucial part of the architectural project, digital fabrication becomes a need. There are companies that understand digital fabrication as a standard as well as personalized process. So when an architecture office presents a personalized idea for a material, they are able to use their equipment.

Concerning this subject, architect Pedro Campos Costa was interviewed regarding the extension of Lisbon's Aquarium (Oceanário de Lisboa) [Figures 4 and 5]. During the interview the architect explained that when they asked Cumella industries for the pieces that make the customized façade of the building, in the beginning it was supposed to be a self-supporting ceramic but, due budget restrictions and for security reasons, it end up being a ceramic covering in a metal structure attached to the wall [Figure 6].





Figure 4. Lisbon Aquarium 2008, material explored: ceramic facade, Lisboa, Portugal. (Costa, 2011).



Figure 5. Inside the cafeteria in Lisbon Aquarium, Lisboa, Portugal.



Figure 6. Lisbon Aquarium construction of the façade, Lisboa, Portugal. (Photography by Campos Costa Architects).

By then, Cumella industries, based in Barcelona, Spain, had no means to make the pieces through digital fabrication, but now the facilities have been upgraded [Figure 7] and, as architect

Pedro Campos Costa said, even if there is a challenge that they cannot make some parts of the production in their facilities, they have a network of partners that are able to deliver those parts.

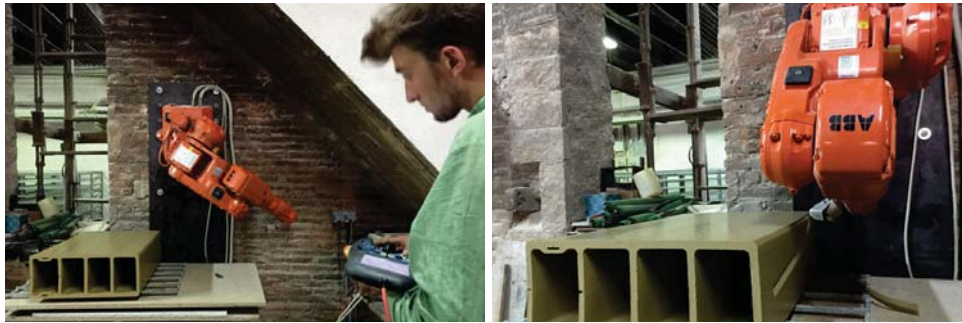

Figure 7. Cumella's facilities, robotic arm demonstration for an IAAC (Institute for Advanced Architecture of Catalonia) class (Blog, 2015).

Especially focusing in the interior of the building, the team in DigitaLab, was considered for these research [Figure 8 and 9], as a paradigmatic case that besides being connected with the academy, already begins to have presence in the market, not only by the way it approaches these technologies in its work, as by the strong and growing relationship with the industry.



Figure 8. Oliva Palito Cafeteria 2016, explored material: cork, São João da Madeira, Portugal. (Photography by André Rocha)



Figure 9. Oliva Palito Cafeteria, production of cork coverings 2016, SOFALCA facilities, Portugal. (Image by AMÁLGAMA produção de vídeo) (SOFALCA, 2016).



### The interviews

Representing each of the subjects above, four interviews were conducted to the referred architects, due to the extension of the interviews a table is presented summarizing the testimony of each architect.

Questions	José Pedro Sousa	Rafael Calado	Pedro Campos Costa	Ana Fonseca
Digital fabrication in the professional path <i>When it appears for the first time?</i> <i>Why choosing it compared with other tools?</i>	During studies.  Depends on the project needs.	FabLab program. Curiosity in experimenting the technology.	Curiosity about the technology in solving specific problems in the building	During studies.  Depends on the project needs.
The connection with the industry <i>How it started?</i>	PhD experiments	In the profession	In the profession	Curiosity regarding the production process
<i>How is the relationship with Portuguese architecture?</i>	Either to consume the product or to innovate it.	Hard to find companies that customize a product.	Hard to find companies that customize a product. A network of contacts is essential.	A balance between innovation and production optimization.
The FabLab <i>Ever used it?</i> <i>(To Rafael Calado: Do architects use it?)</i>	FabLab Barcelona, OPO-Lab.	Mostly for interior design.	Vitruvius FabLab ISCTE-IUL.	Vitruvius FabLab ISCTE-IUL, FabLab EDP.
<i>What is its contribution for the Portuguese architecture?</i>	Through the prototype, making models, exchange knowledge, use unknown technology.	Through the prototype, making models, exchange knowledge, use unknown technology.	To produce fast and cheap prototype.	The environment of the space and it connects people and professionals.
Digital Fabrication in education <i>Is it important for an architecture student to learn it?</i>	Yes, it is another way to think, represent and build something more complex if necessary.	Yes, but it is necessary to optimize, filter and rationalize it, not losing architectural quality.	Yes, for the handling of the prototype or building something, but not losing	Yes, for the proximity to the material, it allows the discovery of new ways of building.



			architectural quality.	
The scale factor <i>Why few examples in Portuguese architecture and a lot in design?</i>	Depends on the culture, but it is used if useful and sometimes one cannot notice it.	Cost, scale, laws, relationship between quality and price.	Laws and insurances.	It is connected with the strategy; it is possible to mix technologies.
<i>Is it possible to build an entire building with digital fabrication in Portugal?</i>	It implies an automatized process; digital fabrication is just a part of it.	Not yet, one needs to guarantee the material and structure.	Not yet, the industry needs to change.	Yes, by interpreting technology through unconventional means.
The future <i>What will be the technologies that will stand out in the Portuguese scenery?</i>	Knowing what exists available, interpret it and contribute for innovation.	Robotic arms and automated processes.	Drones for analyzing, transporting materials and working with tools.	Collaborative processes, creating a network for different parts of production.

Table 1. The architect's resumed opinions regarding the questions asked.

## The results

Regarding the emergence of digital fabrication in the professional path of these four architects it is clear that curiosity in the technology was what made them get in touch with digital tools, either during their profession or still as architecture students. Regarding the use of these tools in the moment of building (prototype or real scale) it depends on the needs of the project.

The connection with the industry is essential, either to explore a specific material or to redesign something that already exists or redesign something from the beginning and optimize for production or simply to consume what it is available.

As for the FabLab context, all of the architects interviewed used this kind of facilities at some point or are still using them. To Rafael Calado, as coordinator of the FabLab Lisboa, the question was made in that perspective and it was possible to understand that architects look for FabLabs essentially for the prototyping of interior design or product design.

All the four architects agree that it is important that architecture students learn about these technologies, but as José Pedro Sousa refers "... it is another way to think, represent and build something more complex if necessary", so it does depend on the technology, depends on the project and its needs, as Pedro Campos Costa and Rafael Calado said it is essential "not losing architectural quality".

For the scale factor and the future, there is still a long path for digital fabrication in Portuguese architecture to travel; the first moment would be to adapt our laws and norms for the reinterpretation that this technique brought to the materials as well as the structures that can be created. Second the industry in the building sector has to understand the benefits of automatized processes and start to invest in machinery that can bring construction costs down. Nevertheless, the idea that Ana Fonseca shares about a collaborative industry can be a big shift, companies would not work in a line of production they would work in a network of production, reducing cost and allowing more options and approaches.





This idea matches with the way of work of the company where Pedro Campos Costa made the pieces for the façade of the Lisbon Aquarium, in Barcelona, Spain, a company named Cumella. At the first look these pieces seem to be digitally fabricated, but by then the company had no means for that (something that changed over the years [Figure 7]), so they start by hand with a prototype and then they used a network of partnerships to help in some parts of the production process.

## Conclusion

With this research, with the testimony of these four architects, it was possible to understand that the architecture process in Portugal is changing from a traditional process to a network of information from idea to construction, from the first scratch to the finished materials.

Depending on Portuguese architects today, digital fabrication has a lot of potential either for producing parts of the building or even in the construction of the whole project, but due to political and economic situations this might be a long term process for the reality of this country. In order to be more widely chosen there will be the need to develop new regulations regarding the use of these kind of tools including formal certifications of the technologies and tests made in new materials and structures, allowing the industries and contractors to invest in more research and resources. Eventually, the costs of this approach will drop and it might turn out to be a more affordable method.

The consciousness about these technologies already exists but need to be spread within the younger generations, having spaces and industries open and connected as communities, with different backgrounds allow for different knowledge connections and approaches, and this becomes fundamental for innovation.

Knowledge about the new technologies is essential to progressively develop the interest and curiosity about the potential given by ne technologies. This fact stresses the importance of academic education on these technologies as well as (by consequence) their use by the practitioners. Society also needs to adapt to the fact that many times the ideation is ahead of the existing products and induces the drive for researching and producing new material and construction solutions by reinterpreting the potential of digital fabrication technologies.

Compared with the international panorama the use of digital fabrication in Portuguese architecture still has a long path, but having the industry, the academic and the user working in a collaborated environments can be the change needed for the acceptance of this tools and ultimately make the whole architecture and construction processes more rentable, sustainable and optimized.

## Acknowledgments

The completion of this study could not have been possible without the expertise of Professor José Pedro Sousa, Rafael Calado, Pedro Campos Costa and Ana Fonseca, whom the authors would like to thank the wise words and advices.

## References

Blog, I., 2015. *OTF2015 // Visit to Ceramica Cumella*. [Online] Available at: <http://legacy.iaacblog.com/blog/2015/off2015-visit-to-ceramica-cumella/> [Acedido em Jan 2017].

Branko Kolarevic, e. a., 2003. *ARCHITECTURE IN THE DIGITAL AGE Design and Manufacturing*. Branko Kolarevic, ed. New York and London: Spon Press.



- COMPETE, 2012. *FabLabs já chegaram a Portugal*. [Online] Available at: <http://www.pofc.qren.pt/Media/Noticias/entity/FabLabs-ja-chegaram-a-Portugal> [Acedido em Jan 2017].
- Costa, P. C., 2011. *LISBON AQUARIUM NEW EXTENSION*. [Online] Available at: <http://camposcosta.com/en/lisbon-aquarium/> [Acedido em Jan 2017].
- DFL, 2016. *The Corkcrete-arch*. [Online] Available at: <https://df1.arq.up.pt/portfolio/corkcrete-arch/> [Acedido em Jan 2017].
- Duarte, J. P., 2007. *ENTREVISTA - José Pinto Duarte* [Interview] (7 September 2007).
- Gershenfeld, N., 2007. *Fab: The Coming Revolution on Your Desktop-from Personal Computers to Personal Fabrication*. s.l.:Basic Books.
- Gershenfeld, N., 2012. *How to Make Almost Anything - The Digital Fabrication Revolution*. s.l.:Foreign affairs.
- Groover, M. P., 1996. *Fundamentals of Modern Manufacturing, Materials, Processes, and Systems*. New Jersey: Prentice-Hall, Inc..
- Laboratory, D. F., 2013. *Digital Fabrication Laboratory - PROFILE*. [Online] Available at: <https://df1.arq.up.pt/mission/> [Acedido em May 2017].
- Lisboa, C. M. d., 2013. *Fablab Lisboa, um espaço para a criação sem limites*. [Online] Available at: <http://www.cm-lisboa.pt/noticias/detalhe/article/fablab-lisboa-um-espaco-para-a-criacao-sem-limites> [Acedido em May 2017].
- Maker, M., 2004. *Maker Faire*. [Online] Available at: <http://makerfaire.com/maker-movement/> [Acedido em May 2017].
- Mitchell, W. J., 2001. Roll over Euclid: how Gehry Designs and builds. Em: N. Y. G. M. Publications, ed. "*Frank Gehry, Architect*". s.l.:s.n., pp. pp 352-363.
- Oliveira, M., 2014. *Arquitetura e Personalização - O Impacto das Tecnologias CAD/CAM*. Porto: Faculdade de Arquitetura da Universidade do Porto.
- SOFALCA, D., 2016. *GENCORK*. [Online] Available at: <http://www.gencork.com/site/>
- Sousa, J. P., 2005. Novos processos. Nova arquitetura? (parte 2). *Arquitetura e Vida*, 64(Tecnologia Digital), pp. 28 - 32.
- Sousa, J. P. O. M. d., 2010. *FROM DIGITAL TO MATERIAL: RETHINKING CORK IN ARCHITECTURE THROUGH THE USE OF CAD/CAM TECHNOLOGIES*. Lisboa: Instituto Superior Técnico, Universidade de Lisboa.





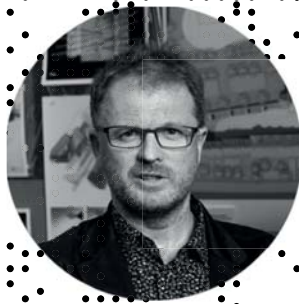

SESSION 03

DIGITAL DOUBLES, COLLIDING IN MID-AIR

Bob Sheil & Thomas Pearce

*Human-inspired Seismic-controlling Autonomous Structures*

Wilfredo Méndez, Esmeralda Niño



*Between the Shadow and the Geometry of Light*

*Hestnes Ferreira in continuity with Louis Kahn*

Alexandra Saraiva



*Translating Algorithmic Design from CAD to BIM*

Renata Castelo Branco, António Leitão



*A chemical paradigm: Matter behavior as heterarchical organizations to generate a design method for resilient city patch*

Orkun Beydağı



*Origami Textures for Adaptive Plate and Shell Structures*

Maurizio Giodice, Francesco Romeo



*Adaptability in the Built Environment Through The Use of Transformable Architecture*

*An exploration into the architectural why and engineering how*

Mia Tsiamis, Ryan Haselman



*Musical Morphogenesis - A Self-Organizing System*

Maria João de Oliveira, João Pedro Sousa, Vasco Craveiro Costa,

Sancho M. Oliveira, Ana Mena





## Digital Doubles, colliding in mid-air

Bob Sheil and Thomas Pearce

“I am in another room, I am crying.  
You said hurtful things to me and you weren’t sorry.  
Right now you are on a bus eating cake.  
The woman sitting next to you died six months ago.”

SHUNT, The Scan

In our digital age, the human eye has lost its privileged position as the sole and central audience of an unfolding perspectival world, as it finds itself challenged by a plethora of post-human eyes. Emerging technologies of vision such as 3D laser scanning—regarded as less faulty, faster and more accurate than the human eye—find an ever more central role in production, analytics, control and decision making.

Architecture and scenography, practices that are both firmly shaped around the centrality of vision of the human subject, are challenged to find novel ways to address a hybrid audience of human and non-human modes of vision. *The Scan* (2013) is a prototype for a post-human scenography that develops 1:1 collaborative and site-specific acts between designers and performers through 3D scanning, bespoke instrumentation, rehearsals and live performance.<sup>24</sup>

With a particular emphasis on how 3D scanning may be manipulated in situ, the work seeks to mediate between live performance and digital representation, and thus explores a new relationship between performance and audience through time and location. Creatively appropriating and instrumentalising machine vision for a novel post-perspectival and post-anthropocentric scenography, the work simultaneously dismantles the spatio-temporal realism of this vision while forwarding hybrid and fragmented notions of site/stage, subjectivity and authorship.

### reshuffling the cards of reality

The development of *The Scan* combines two research interests that have been central to the Protoarchitecture Lab’s body of work over the past few years: firstly, the exploration of performative space, which led to an ongoing research collaboration with the Royal Central School of Speech and Drama (RCSSD);<sup>25</sup> secondly, a critical and subversive approach to novel technologies of digital fabrication and representation.

With regards to 3D laser scanning, this approach shifts the emphasis from a positivist fascination with the congruence between the physical world and its digital representation towards a growing interest in the disjunction and discrepancies between the two. Such discrepancies appear in the case of measuring errors, which create a so-called “noise” in the point cloud, for example when the scanner’s laser beam hits a reflective surface or the edge of an object. This noise, digital points that do not correspond to any actual physical object, is normally filtered out of the point cloud elaborately.

---

<sup>24</sup> The work is the latest iteration of a creative collaboration between the Royal Central School of Speech and Drama (RCSSD), ScanLAB Projects and The Protoarchitecture Lab at The Bartlett School of Architecture, UCL. The artists’ collective SHUNT created an original score for the performance at the RCSSD.

<sup>25</sup> See SHEIL, B. and SHAW, M. (2011), ‘Perform: a prototype for making theatre and theatre making’. Presented at the International Adaptive Architecture Conference, Building Centre, London (Mar 2011). Published as part of conference proceedings, 2–13.

We recognize this noise as a space of potential occupation and artistic appropriation, as it turns the scanner from a passive *realist* measuring tool into an active *surrealist* agent that *creates* spaces in the digital realm. The artistic appropriation of this noise starts with the understanding of the physical and geometrical principles that lie at its origin, and leads to the reverse-engineering of these principles, so that the noise can be controlled and purposefully created. As such, the scanner can be turned into a phantasmagorical device of engineered illusionism. This allows us designers to create fictional digital spaces and illusionary environments through understanding and then misusing the rules of representational techniques.

The suitability of such subversive scanning strategies of engineered illusionism for scenographic purposes is evident: they echo the very origins of the discipline of scenography, which was first developed by artists practising illusionistic architectural painting techniques such as *quadratura* and *trompe l'oeil*. Such anamorphic illusions, suggesting the extension of a given space beyond the surface of a painted wall or ceiling, were in turn used for the creation of illusionary environments in stage designs.

The technique of representation crucial to these engineered architectural and scenographic illusions was the development in the Renaissance of the rules of perspective. Bruno Latour describes the double role of perspective as a tool of realism and illusion as the “four-way freeway” of representation: perspective does not only allow us to realistically represent a scene (one-way freeway) or to pragmatically act upon an external reality (two-way freeway); not only can we

*“displace cities, landscapes, or natives and go back and forth to and from them along avenues through space, but we can also reach saints, gods, heavens, palaces, or dreams with the same two-way avenues and look at them through the same ‘windowpane’ on the same two-dimensional surface. The two ways become a four-lane freeway! Impossible palaces can be drawn realistically, but it is also possible to draw possible objects as if they were utopian ones.”*<sup>26</sup>

Thus, perspective is a *technique* of realistic representation rather than a dogma of realism of the subject matter depicted.<sup>27</sup> And mastering this technique allows us not only to depict a “reality” but also to challenge it. Perspective, to speak with Latour again, is a technique with which we can create “complete hybrids between the real and the imagined: nature seen as fiction, and fiction seen as nature, with all the elements made so homogeneous in space that it is now possible to reshuffle them like a pack of cards.”<sup>28</sup>

## a post-perspectival illusionism

This “four-way freeway”, however, cannot be directly translated to the case of the 3D scanner, as its relation between data collection and representation is more complex and less direct than is the case for classical perspective. We could in fact state that 3D scanning functions at once in a post-perspectival and pre-perspectival way.

To elaborate on this statement, it is critical to very briefly explain how a 3D laser scanner works. The scanner’s range finder measures the distance between itself and objects in a scene by using time-of-flight measurement: shooting laser beams at the objects, it converts the signal’s return time to a distance value. Constrained only by the speed of light, it can create millions of measured points per minute, which can then be translated into a set of three-dimensional x,y,z values.

Similar to other technologies of remote sensing (e.g., radar), the scanner is post-perspectival: although it collects data from a fixed position, it does not have a picture plane, retina or photographic plate. In this sense, speaking of the scanner “eye”—as we have done until now—is in fact a case of stubborn anthropomorphism that resorts to an essentially humanist epistemological

---

26 LATOUR, B. (1986), *Visualisation and Cognition: Thinking with Eyes and Hands*, in: H. Kuklick (ed.), *Knowledge and Society Studies in the Sociology of Culture Past and Present*, Jai Press, vol. 6, 8.

27 Cf. FRIEDBERG, A. (2006), *The Virtual Window: from Alberti to Microsoft*. Cambridge, Mass, MIT Press, 33.

28 LATOUR, *Visualisation and Cognition*, 9.



understanding of the human observer as the active knowing subject acting upon the passive known—be it real or manipulated.

At the same time, the scanner's measuring method is pre-perspectival: the translation of collected distance values to  $x,y,z$  values and their representation on a perspectival picture plane is but a matter of post-processing to make the point cloud data legible to the human eye. This means that, as opposed to classical perspective, in which the viewer's position had to be identical to the painter's, the observer's location is no longer necessarily "encoded into its representation".<sup>29</sup> Instead, she/he can now freely navigate through the point cloud space—echoing futurist Bruce Sterling's speculations on the future of the camera which

*"simply absorbs every photon that touches it from any angle. And then in order to take a picture I simply tell the system to calculate what that picture would have looked like from that angle at that moment."*<sup>30</sup>

These considerations imply that techniques of "scanning illusionism" cannot simply operate on the level of "realist" representation (simulating fictional narratives within the flat constraints of pictorial representation)—but instead will have to engage with this pre-perspectival stage of data collection. As this data collection (the actual measurement) is firmly embedded within the material reality of the measured scene,<sup>31</sup> the trigger for such illusionism will necessarily lie in the realm of physical intervention and thus become a spatial, architectural challenge.

## a live survey

As a prototype for a post-human scenography, *The Scan* applies such a post-perspectival engineered illusionism to create a "stage" that is marked by hybridity—hybridity between physical and digital performance spaces, and hybridity between realist and fictitious spatial representations. The physical stage for *The Scan's* scenographical investigations is the premises of the RCSSD. The attraction of these spaces lies in their labyrinthine quality: it is a conglomerate of buildings that has been extended, added to and layered upon, a complex set of spatial relations that becomes legible only through a longer experience of navigating its rooms—but even then would need a set of universal keys to reveal its unexpected backdoor connections.

In a first stage of the project, a survey of the building is conducted using the 3D scanner. Looking at perspectival representations of the assembled scans, the opaque walls and floors of the buildings dissolve as they are turned into clouds of millions of points, whose pixel size and hence opacity can be controlled within the digital model. The spatial correlations, lost in the additive complexity of the floor plans and labyrinthine circulation, become transparent and legible. (Figures SCANLAB 1, 2 and 3)

---

<sup>29</sup> FRIEDBERG, Virtual Window, 28.

<sup>30</sup> STERLING, B. (2010) Vernacular Video [Lecture at the Vimeo Awards Festival], New York, 9 October.

<sup>31</sup> Karen Barad uses precisely this kind of time-of-flight measurement to illustrate the material entanglement of processes of knowing (the materiality of the laser beam) with processes of being (the measured material object) and to define her concept of an entangled onto-epistemology. BARAD, K. (2007) *Meeting the Universe Halfway: Quantum Physics and the Entanglement of Matter and Meaning*. Durham: Duke University Press, 78.



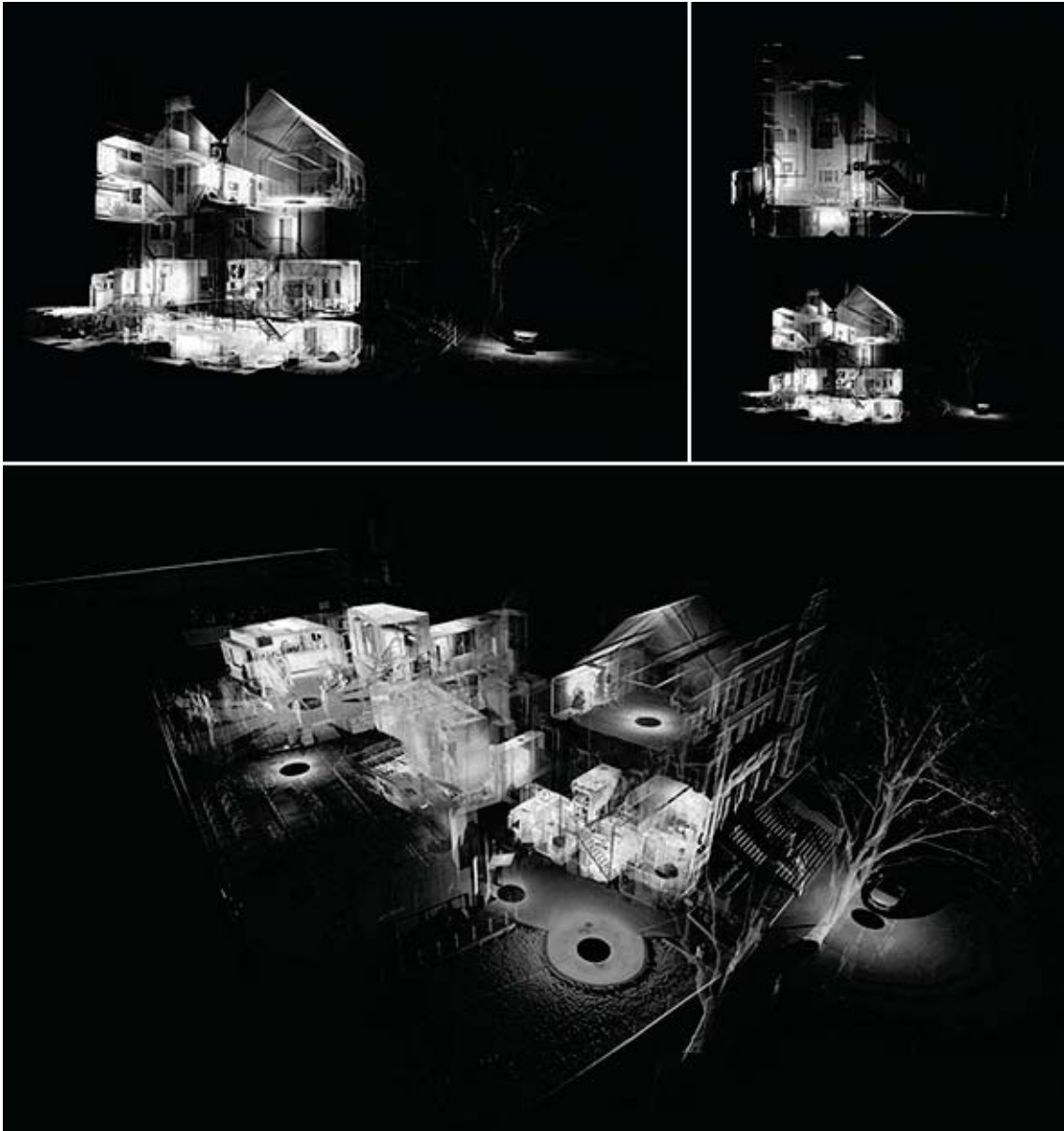

*Figures SCANLAB 1, 2 and 3.*

The exercise to scan the RCSSD is simultaneously exploited for performance experimentations, which challenged the conventional metrological use of the “realist” scanner. The experiments, conducted by the artists’ collective SHUNT, intervened across a suite of scheduled capture positions with unscheduled performance tests that explored conditions such as sound, movement, materiality, dialogue, montage, blind spots, building fabric and narrative.

A first set of performance experiments created narrative tableaux wherein the actors, like in early photography, would stand still waiting for “full exposure” while the scanner’s rays swept past them (depending on resolution and accuracy, the scanner describes a 360° rotation that creates tens of millions of measured points in a matter of minutes). Soon, however, the performers recognized this very rotational movement as inherently choreographic, a time-based constraint and

opportunity creating a narrative space to be inhabited by their performance. It meant that, for example, one moving performer could appear multiple times within a single scan. Also, as the scanner reads a scene as concentric sections of reality, it can slice a moving body, disassembling, warping and extending it. (Figures SCANLAB 4, 5, 6, 7, 8 and 9).

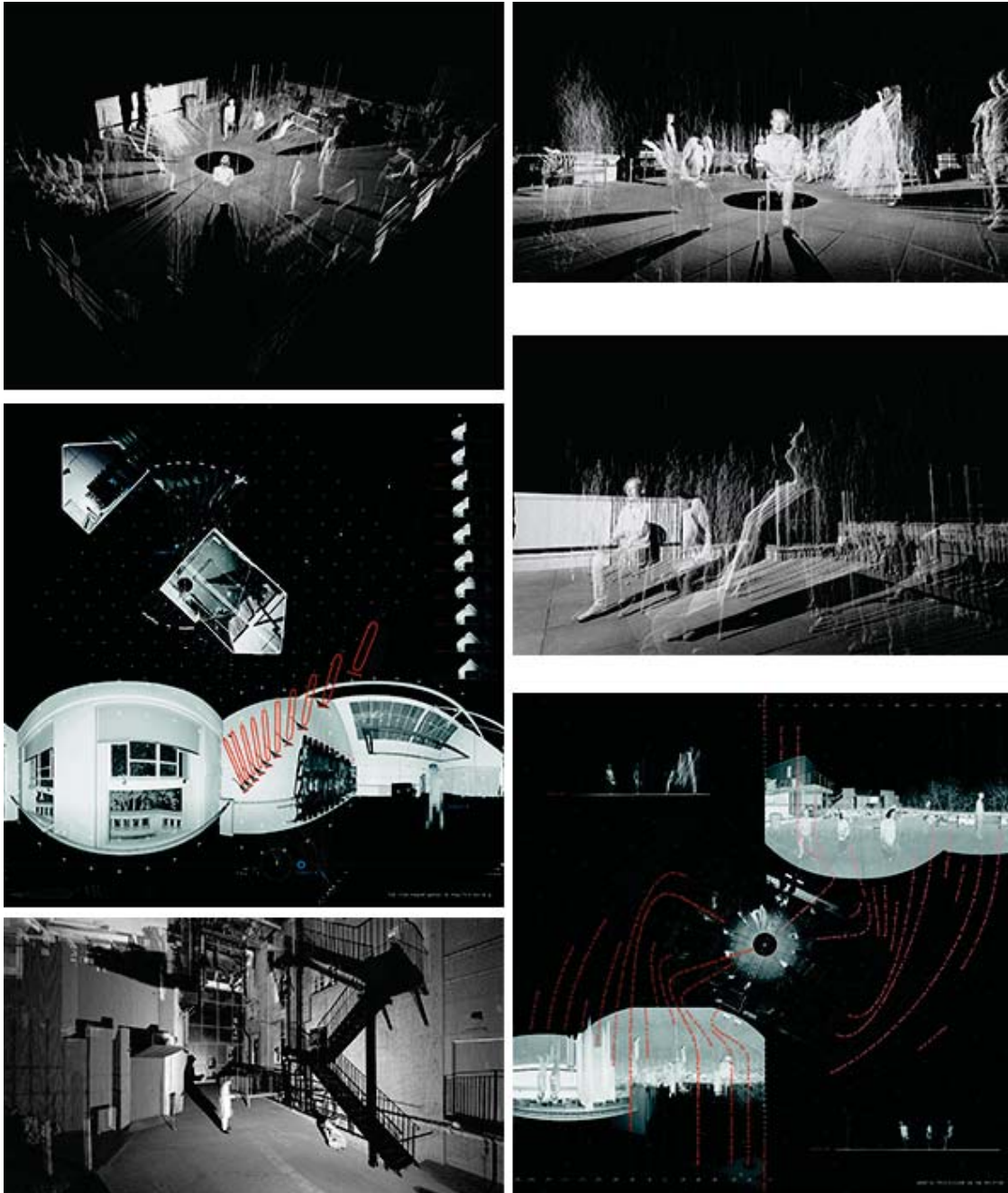

*Figures SCANLAB 4, 5, 6, 7, 8 and 9.*

The notion of time-based tableaux or of a “live” site survey emerged, and established the ambiguity between the forensic accuracy and “realist” capture of the scanner on the one hand, and its phantasmagoric, fictional, and deceptive potential on the other—an ambiguity that would remain the principal impetus of the rest of the project.

## bending a blind man’s cane

One key scene, called “The Crying Room,” enacted and scanned during this process of live surveying, would become crucial to the further development of the piece. The scene involved a woman, crying and reciting a text in front of a large mirror in one of the RCSSD’s many rehearsal rooms. The resulting point cloud model showed a non-existent, mirrored digital room, in which the performer’s “blind side” appeared. (Figures SCANLAB 10 and 11).



Figures SCANLAB 10 and 11.

This is explained by the fact that the scanner’s laser ray measures strictly one-dimensionally—rather like Descartes’ (faulty) description of human vision as a blind man stabbing his cane in the dark until it meets an object. What happens here is that this cane is “bent” or deflected by the mirrored surface and travels on to meet an object in front of the mirror. The ignorant blind man (the scanner), however, assumes that the object lies in the extended direction of his stabbings and thus digitally creates this parallel, fictional room behind the mirror.

This result provoked an interest in developing the reflected data as a parallel performance space exclusively within a digital environment. A design and prototyping phase followed, with the aim of transforming these mirrored spaces from incidental digital spillages into purposefully created mirages. Custom software components were scripted; these reverse-engineer the reflections created by parametrically controlled reflective panels and can calculate the position of the resulting displaced point clouds in relation to the performance position. [Image 35](#)

## digital doubles, colliding in mid-air

Adding digitally fabricated spaces using these simulation algorithms provided a new scenographic strategy towards the given site conditions, a strategy governed by the ambiguity between making the labyrinthine building transparent and legible on the one hand and, on the other, the urge to continue and emulate the additive complexity of the as-found physical space through an equally complex juxtaposition of fabricated spaces—hence adding even more digital “rooms” to the building.

A series of positions within the RCSSD building were selected to receive the installation of paired bespoke instruments creating such digital performance spaces. Each of these paired instruments incorporates a 3D scanner head mounted on an armature that faces a second housing of

programmable reflective panels. The reflective panels, rather than being a scenography in their own right, are both signifiers of and triggers for the digitally extended scenography. Like in illusionist baroque painting, surfaces become a portal to a further three-dimensional space that supposedly/digitally lies beyond them.

A first scene, staged in a staircase, involves three pairs of mirrors, through which a scanner on the upper floor captures a single performance taking place on the lower floor, simultaneously from three different angles. These three different “views” are projected outwards (using the logic of the blind man’s broken cane—which in this case is broken twice) and are digitally created as fictional spaces floating above the courtyard. This scenario is not only post-perspectival but also post-Cartesian, as it explodes, multiplies and scatters the  $x,y,z$  values of a single geometric entity into a digitally displaced, multi-perspectival point cloud. (Figures SCANLAB 12, 13 and 14).

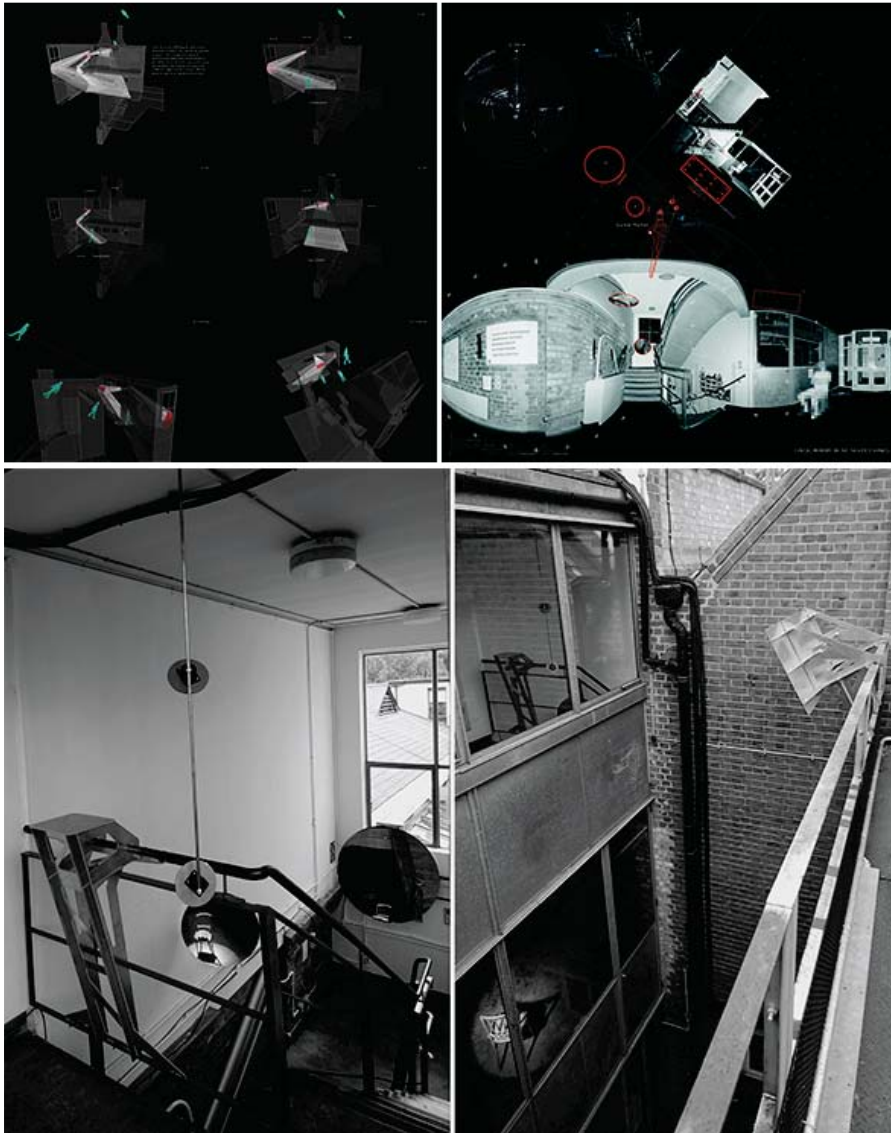

*Figures SCANLAB 12, 13 and 14.*



A second scene is developed for the ballet room, in which the two techniques described above—the scanner’s rotational choreography and the reflective screens—are combined. An array of ten mirrors delicately balances from the ballet rail and against the wall, lined up like serially connected metallic ballerinas. As the scanner makes its rotational movement and sweeps across these mirrors, each mirror consecutively reflects its rays towards one and the same focal point for the duration of a couple of seconds. Hence, a performance, taking place on this “hot spot,” is reflected, scanned and digitally “created” ten times behind the mirrors. Hovering three stories above ground, a four-dimensional “film reel,” a spatialised Muybridge image sequence occupies the space beyond the wall, capturing the performance in ten consecutive “frames.” (Figures SCANLAB 115, 16, 17, 18 and 19).

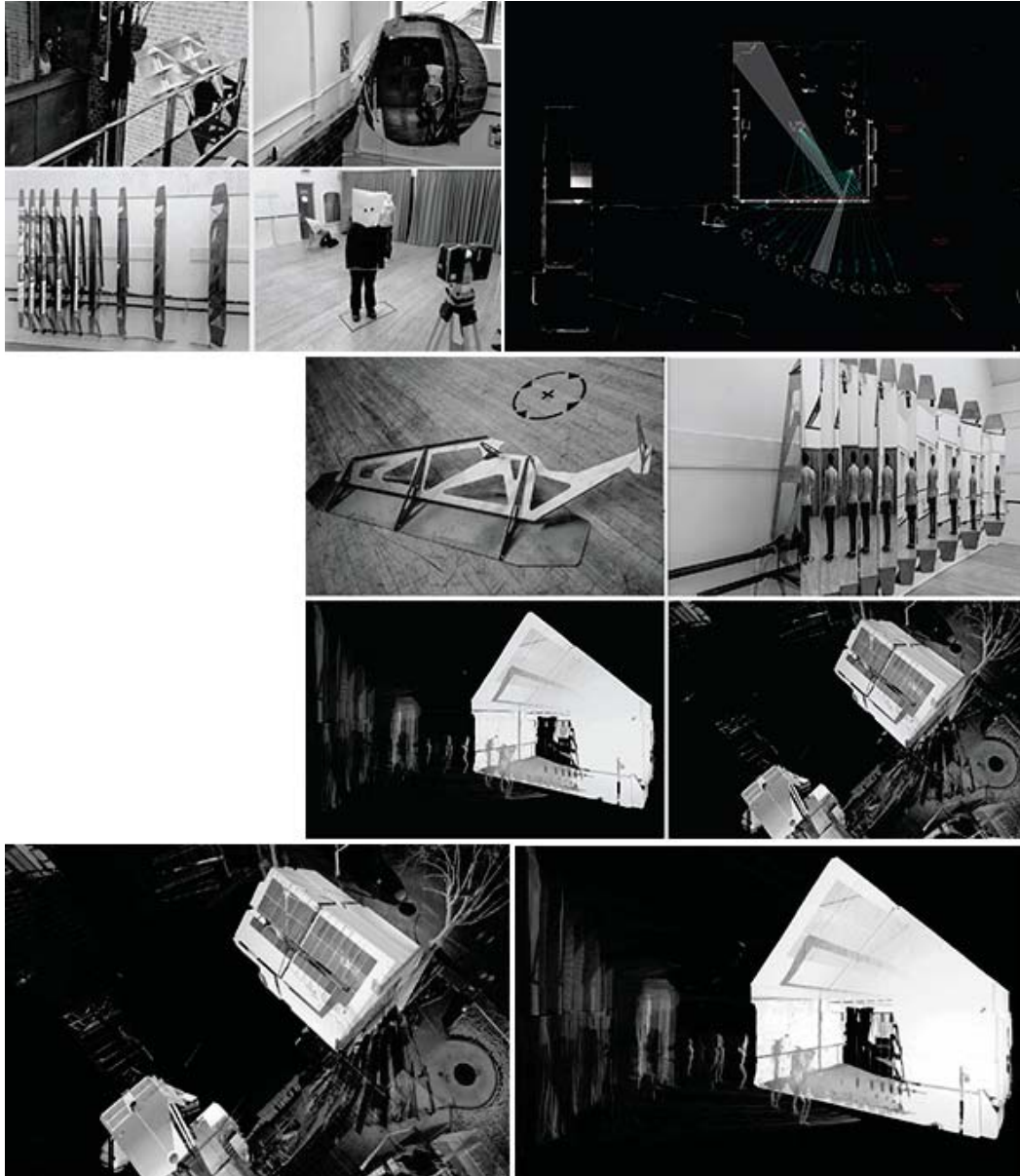

Figures SCANLAB 15, 16, 17, 18 and 19.



The performers, by studying analytical drawings and through scanned rehearsals and explorations of the resulting digital point cloud mirages, become accustomed to inhabiting and interacting with this four-dimensional scanner-timed scenography. They become guides for the audience and their projected digital doppelgangers.

## re-fragmenting the mirror stage

As time and gestures are exploded in space, the spatial and temporal realism of the point cloud is dismantled. Instead of the snapshot quality of a “unique” moment in time and space, a complex layering of a multiplicity of both unfolds. With this spatio-temporal disruption, the notion of the autonomous performer/audience/subject as a unique spatial and temporal individual is exploded, too. If in the classical Lacanian theory of the so-called “mirror stage” the child, by recognition of an image of the “self” in the mirror, develops an “imaginary wholeness” and self-consciousness, the mirrors in our case are used quite to the opposite end: they are devices that re-fragment notions of selfhood, identity and subjectivity.

This spatially scripted sense of fragmentation and displacement also becomes part of the spoken script of the piece, in which the role of the audience, which is led through the (digital and physical) spaces by the performers, is constantly obfuscated and made ambiguous:

*“A: This is a summary of events.*

*You are all here.*

*We are walking in a circle together.*

*B: You aren’t here.*

*You’re jumping through walls and looking at yourself in the mirrors.*

*In some you look fatter.*

*There is no circle.”*

The audience’s—partially uncomfortable—submission to the machine-timed and machine-recorded choreography destabilizes its usual centrality as the singular consuming perspectival “eye” to which the piece is directed. As many scenes are acted out for the ominous post-perspectival eye of the scanner, the audience loses its privileged position—reflecting a post-anthropocentric reality in which a plethora of heterogeneous non-human eyes and agents have complemented or even replaced human vision.

The audience is thus confronted with its own inability to grasp the full “picture” of what is happening. This is not only due to the relative novelty of 3D laser scanning technology to most of the audience, but also to the conscious curatorial decision not (yet) to provide visual feedback about the spaces being digitally created, as this would merely re-establish the perspectival centrality of the detached human observer and thus reinstate the “scopic regime” or “Cartesian perspectivalism.”<sup>32</sup>

Parallel to the displacement of the audience’s privileged spectatorship, a shift takes place towards a sense of audience authorship—however unclear this authorship may be at the moment of the actual performance—and hence towards an erosion of the sole authorship of both scenographer and performer. The humanist notion of an active subject/author, *acting upon* a passive world of objects—matter in the case of the architect, the audience in the case of the performer—is dismantled in favour of a notion of co-authorship over unfolding events.

From the onset, a fertile friction arose between our scenographic intentions—the prescriptive clockwork choreography described above, assuming the magician’s (all too) perfect control over the engineered surrealism of the test person’s reflective fragmentation—and each performer’s

---

32 Cf. JAY, M. (1988), *Scopic Regimes of Modernity*, in: FOSTER, H. (ed.), *Vision and Visuality*. Seattle, Bay Press, 4.



associative interpretation and the audience, unknowingly stepping in and out of a “hot spot”, a cross that marks their simultaneous vertiginous suspension fifteen meters above the courtyard behind the wall.

This notion of shared authorship, however, goes beyond what would be commonly categorized under “public participation”—as it is not confined to the human actors involved but extends well beyond, into a more ontological sense of participation that comprises human and non-human “actants” alike.<sup>33</sup> The scanner, for example, becomes a central actor/actant in the piece. This is true in both a literal sense—the scanner being referred to in the text, being turned into an ominous and wondrous object, a spatial mediator around which the performance revolves—and in an epistemological sense—the scanner not just being a passive *camera obscura* capturing the scene, but an operative agent actively creating and augmenting the scene. As such, all human and non-human agents form a network that mutually creates the unfolding of the co-authored piece.

## no applause

In the final act of the piece, after being guided through the building and along a series of scenes and scanner-timed choreographies, the audience is led through the backstage area and gathers on the stage of the RCSSD’s theatre. The space is dark, the auditorium hidden behind the fire curtain. Projected on to the back of the fire curtain is a dense multimedia relay of point clouds, 3D models, animations, CCTV footage, infrared footage, photography, sound recordings and dialogue recorded during the piece. The performers sit lined up behind a long table full of computers and technical equipment and in front of the projections, facing away from the public. In hushed, barely understandable voices they discuss the projected material. They react indifferently to the intrusion of the audience, suggesting a process that has started long before the audience arrived and will continue after they leave. (Figure 20).



Figure 20.

---

<sup>33</sup> This concept of actants is suggested by Jane Bennet, Cf. BENNET, J. (2010), *Vibrant Matter: A Political Ecology of Things*. Durham, Duke University Press.



Again, the members of the audience no longer sit comfortably in their detached and privileged auditorium but instead become aware that they have been performers themselves, observed by a multitude of post-perspectival eyes. The choice of the backstage location is of course symbolic, displaying the system of pulleys, ropes and counterweights that normally provides the machinery and armatures for illusionistic scenographies. Now surrounded by this machinery, entangled in the inner workings of the performance, the audience is immersed in the unintelligible hyper-analysis of their own actions. Marking the end of the piece, the fire curtain rises. The projections disappear and actors, scenographers and audience face the auditorium. It is empty. There is no applause.

## digitally fabricating / fabricating digitality

The largest part of the multi-screen display is taken up by projections of point cloud models. The scans are composited, digitally stitched together, as is normally done after a scanning survey—except that now, digitally created, parallel performance spaces appear, imploding the building's spaces into the courtyard. Hovering above the courtyard, mirage spaces overlap, performers and members of the audience hang upside down, protrude through walls or intersect with the fire escape staircase. While some fly-through animations are made before the evening of the performance, stitching together scenes from the initial survey and juxtaposing them with point clouds created during rehearsals, other point cloud displays are shown “live” by an operator panning through a model, layering “fresh” material from the evening's scans on to previous point clouds, further destabilising time-scales. The operator zooms in on a person's face in the ballet room, the face dissolves into points as we come closer: was this a performer, a member of a previous audience, a mirage?

The process of digital grafting not only deconstructs the spatial realism of the composited scenes, but also undermines the temporal realism of the snapshot moment as it blends and layers time-scales into a non-linear narrative, spatio-temporal assemblage, suggesting the progression of performers through the scenes, playing different roles, enacting different scenes simultaneously. The plausibility of this narrative is constructed through the “optical consistency”<sup>34</sup> of the point cloud—again reminding us of what Latour, in the case of perspective, called “reshuffling the cards of reality.” Indeed, the resulting scenes could be likened to so-called polycenic paintings of the *quattrocento* Renaissance in which, using the then recently discovered (or re-discovered) unifying technique of perspective, multiple sequences of a story (e.g., Botticelli's *Three Miracles of Saint Zenobius*), were depicted within one single perspectival scene, framed by an assemblage of existing and fictional architectural elements.

It would be oversimplifying, however, to consider these spatio-temporal point cloud assemblages as endpoints of the piece—as if describing a linear process of deception and revelation in which a “trick” played on the audience is resolved in a communal revelatory backstage ‘aha!’ moment. This would not do justice to the complex and entangled notion of the digital that was built up throughout the project—a notion shifting from a *mimetic* towards an *augmentative* understanding of digital fabrication.

The mimetic understanding of digital fabrication allows, through the aid of digital metrology (3D scanning), digital design tools (CAD) and digitally controlled manufacturing (CNC), for a heightened accuracy, customization and complexity—but eventually still culminates in the fabrication of physical artefacts. Each consecutive translation between the digital and the physical is measured by the accuracy of its replication—the digital point cloud model is valuable because it accurately and realistically measures and represents the captured physical scene; the physical artefact or insertion is in turn evaluated by the low tolerance of its materialization of the digital design model.

---

<sup>34</sup> LATOUR, *Visualisation and Cognition*, 8.



While working on *The Scan*, a notion of translation and fabrication emerged that is *augmentative* rather than mimetic. When the scenographic insertions, which are bespoke designed based on a “realist” scan and implemented into the site, are re-scanned, our digital point cloud mirages appear as elements that are additionally *created* by that very translation process. The role of the scanner as a tool of *verification* is rendered ambiguous in that it both *checks* the truth (accuracy) of the insertions and *creates the truth* (from *verum facere*, to make true) of the mirages. A novel, extended sense of fabrication emerges which comprises both the digital fabrication of the physical (using scans as a source of information) and the physical fabrication of the digital (using scans as a sources of fiction). The insertions, *digitally fabricated, fabricate digitality*.

## fabricating for an entangled digitality

The reader might sense the danger that, by adding a next stage, however digital (the fabrication of digitality), to a linear fabrication workflow, we might be merely stretching its teleology with a new, yet equally *final* goal. Therefore it is important to note that even the digital point cloud assemblage cannot be read as the new definitive goal, the ultimate repository of our scenographic practice. During the process of our experimental collaboration, a practice emerged that is instead characterised by a constant feedback between physical and digital creation. The digital site, the point cloud archive, becomes a parallel performance stage that is constantly fed by (i.e., being scanned), but also *feeds back into* the physical space.

This feedback of the digital back into the physical affects both the appearance and experience of the physical performance space. Visually calibrated by the mirror and scanner armatures and annotated with markers indicating origins, hot spots and movements, it constantly refers to the parallel digital spaces being created. Maybe even more important, however, is the performer’s accumulation of technical and spatial literacy regarding the resulting point cloud models: after each rehearsal session, performers and scenographers would sit down to explore and navigate through the resulting point clouds, compare and composite them with older results and refine strategies for further rehearsals and performances.

This way, each consecutive rehearsal becomes more and more deeply saturated with both the imprint of a remembered, digitally created space and the anticipation of the digital space being created at that very moment. As the performers develop a sense of simultaneously inhabiting this digital space, they become guides to these spaces, leading the audience through digital pitfalls: “A: We can see things you can’t see // B: It’s not always helpful // A: I can see through that wall // B: It’s not very interesting”.

The performers also develop techniques that creatively exploit the point cloud space’s own peculiar rules and laws, modes of mobility and observation. When one performer, during the piece, starts writing the opening lines of T. S. Eliot’s *Four Quartets* on the exterior wall of a rehearsal space, she does this *backwards*—literally becoming more literate within the point cloud space, she knows that digitally standing within the rehearsal space, she will be able to read it through the wall as soon as it dissolves into points:

*Time present and time past  
Are both perhaps present in time future  
And time future contained in time past.  
If all time is eternally present  
All time is unredeemable.  
What might have been is an abstraction  
Remaining a perpetual possibility  
Only in a world of speculation.*

Eventually, the physical space surrounding us dissolves into points, even without the mediation of its perspectival representation. As in Eliot’s *Quartet*, scales of time and experience are now



Digital Doubles, colliding in mid-air  
Bob Sheil, Thomas Pearce

inextricably mingled, each performance taking place in its present physical space as well as interacting with the previously and presently recorded and soon-to-be represented space. In our digitally saturated age, digital fabrication becomes an ongoing reciprocal, non-teleological process, the digital and physical being both thoroughfares of an emergent digital-analogue assemblage, an entangled continuum in which it is useless to attempt to distinguish what is represented or actual, recorded or created, fact or fiction.



## Human-inspired Seismic-controlling Autonomous Structures

Wilfredo Méndez<sup>1</sup>, Esmeralda Niño<sup>2</sup>

<sup>1</sup>Zero Damage LLC, Puerto Rico, <sup>2</sup>Zero Damage LLC, México

<sup>1</sup>wmendez@zerodam.com, <sup>2</sup>enino@zerodam.com

**Abstract.** Responsive architecture is not only the kind of buildings that people would expect in the future, but also the kind of built environment that they already need. There are many natural events that constantly challenge the strength and resilience of structures worldwide. Despite the fact that several engineering solutions exist to eliminate the risk of major disasters, some natural events still can cause several damage to critical infrastructure and numerous casualties. From all the natural events, major earthquakes are the most catastrophic. Structural behaviour during seismic events has become not only a technical issue of material performance, but a speculative endeavor of creating responsive structures to unforeseen events. By coupling behaviorism with specific artificial intelligence models, we have envisioned a new concept for lateral load bearing based on an electro-mechanical system that emulates the human biomechanics and its body postural control.

**Keywords.** *Autonomous Structure, Responsive Architecture, Biomimicry, Seismic Resilience, Cyber-Physical System.*

### Introduction

The study of earthquake resilience has been a topic of research from many disciplines including material science, structural, and mechanical engineering. According to the United States Geological Service, casualties provoked by earthquakes averages 20,000 a year. Since man has no control over such natural hazards, earthquakes must be considered as unavoidable events. However, neither architectural nor engineering standards have proved to be fully resilient to seismic inputs (Ambrose & Vergun, 1999). In fact, due to the inability of most built structures to properly deal with major earthquake loads, these are the most catastrophic and deadliest natural events. Despite that several engineering solutions exist to ensure that the buildings are resistant to earthquakes, the 6.9-magnitude Kobe earthquake in 1995 and the 8.8-magnitude Chile earthquake in 2010 revealed that full protection from earthquakes does not yet exist. Combined, both earthquakes killed more than 6,000 people due to more than 60,000 buildings collapses in both countries counting with stringent seismic codes. Responsive smart architecture can actually end this systematic worldwide problem.

In a recent publication by The World Bank, the organization stated that natural hazards such as earthquakes not only trap communities in poverty and exacerbate inequalities but also roll back development gains and disrupt livelihoods. A different paradigm on responsive and intelligent building's technology is necessary to properly address major earthquakes inputs. The majority of the buildings and infrastructure already built were essentially designed to remain still. Even contemporary structures designed following stringent seismic codes on structural ductility, were essentially engineered to be static constructions that passively dispel earthquake loads (Chey et al., 2006). The building codes mainly address the inhabitant's safety, but allows for catastrophic damage to the building since designing them as fully resilient structures will be too expensive (Ambrose & Vergun, 1999). At the other hand, advanced seismic solutions such as base isolation and dampers increases construction complexity and, therefore, are exclusively used when no more options are left (Kamrava, 2015). The proposed solution shifts the static concept normally





addressed by architects and engineers for designing the majority of buildings and infrastructure in order to upgrade its performative resilience and challenge advanced solutions constructability.

The human-inspired seismic-controlling autonomous structure was conceptualized as a cyber-physical system. It is an architectural model relying on electro-mechanical engineering and the mechanistic model of artificial intelligence to dynamically counteract the earthquake effects. The project's main objective was to improve architectural resilience by responding to the ground motion just as a human being would behave to preserve its posture. After analyzing human actions towards balance, and mimicking the human skeleton biomechanics we were able to engineer a kinetic layout that replicates human behaviour. The resultant system would not only improve structural performance and the inhabitant's safety, but also will minimize the overall architecture's damage. Besides, the system allows for modular assembly and, thereby, could be easily adapted to different architectural typologies from high-rise to mid-rise buildings.

## Literature Review

Considerable work has been done to prevent or reduce the damage of earthquakes that, from an engineering standpoint, is based on designing and building up structures able to resist the forces generated by seismic waves (Somasekharaiah et al., 2008). Several seismic technologies can be found in the literature reviewed (Elghazouli, 2009). It is evident, however, that the majority of these works has focused in mitigation and savings of structural cost of the building. A review by Islam (2012) reveals that seismic base isolators reduce the dynamic loads induced by the earthquakes but increase the construction cost as well as installation cost, depending on architectural requirements. The work of Sonawane (2016) also classify in the category of base isolator where a comparison is made between base isolators like lead rubber bearing (LRB) at the foundation level and fixed supported building models. From this study, it is found that, by using seismic base isolation technology, the story accelerations are reduced significantly. Seeking to develop isolation systems that can be effective for a wide range of ground excitations, hybrid control strategies, consisting of a passive isolation system combined with actively controlled actuators, have been investigated. Yoshioka et al. (2002) research presents the results of an experimental study of an adaptable, or smart, base isolation system that employs dampers. Eatherton et al. (2014) studied the self-centering rocking steel-braced frame system. The design of this system is examined and contrasted with other conventional and self-centering seismic force resisting systems. Equations to predict the load-deformation of the rocking system were developed. The work of Sabelli et al. (2003) addresses the seismic response of three and six story concentrically braced frames utilizing buckling-restrained braces in order to characterize the effect on key response parameters of various structural configurations and proportions.

The necessity of biologically-inspired concepts and advanced seismic technology beyond conventional solutions brings the potential of use memory alloys. This has been already evaluated by Desroches & Smith (2003); and Sawaguchi et al. (2016). The study provides a critical review of the state-of-the-art in the use of shape memory alloys for applications in seismic resistant design.

Developing engineered structural designs and seismic technology that are capable of withstanding strong ground motions can be achieved either by following building codes based on hazard maps or by appropriate methods of analysis (Elsesser, 2004). Monetary realities commonly determine the goal, not of preventing all damage in all earthquakes but of minimizing damage in moderate, more common earthquakes and ensuring no major collapse at the strongest intensities. Active, semi-active and hybrid seismic-controlling systems as well as biologically-inspired solutions are in widespread use due forces control by real stimulation and improved structural behaviour (Heysami, 2015).

## Bio-inspired Mechanics

Since resilience is defined by the ability of the structure to recover from external perturbations as fast as possible, the human performative resilience to counteract horizontal forces underlies in its behavioural actions to rearrange the skeleton posture for the most suitable channelling of the external loads. These mechanical actions turn out to be a highly complex interaction between the central nervous system and the musculoskeletal system (Horak, 2006). Such human behaviour can be reproduced in its simplest form because it is produced by a known stimulus that generates a measurable response. The stimulus triggers an instinct or fixed chain of reflexes known by behaviourists as fixed action patterns or FAP (Herrnstein, 1977). This relationship between stimulus and FAP frames the mechanistic model of artificial intelligence introduced to computing in 1965 (Frenay, 2006).

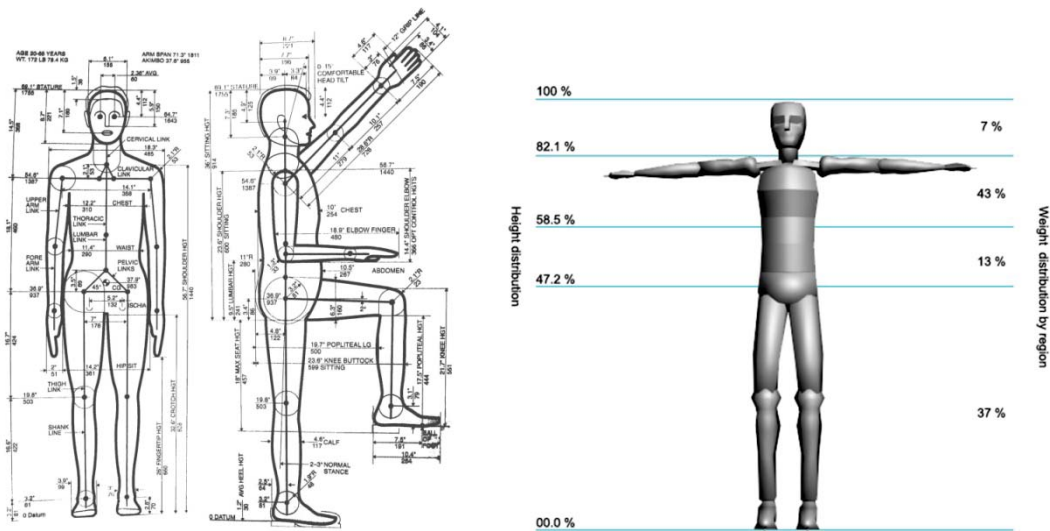

Figure 1. Human body anthropometric parameters and weight distribution

The human motor control is a problem of information processing, coordination, mechanics, physics and cognition (Horak, 2006). Before executing actions and movements, the human body must perceive and process the sensory information. However, human actions not solely rely on this information, but mostly on accurate internal models of the environment, constructed from a combination of perceptual information and prior knowledge (Palmieri et al., 2002). In terms of postural control, the human body perceives a balance distortion through several systems working together: the visual system, vestibular system and proprioception. Then the human instincts trigger the FAP towards balance correction (Abu-faraj et al., 2008). The sensory information is turned into electrical signals that the motor control system distributes in a synchronized manner among the 200 main skeletal muscles to generate forces which actuate joints. Hence, the skeleton rearranges following a chain of reflexes in a closed loop and self-regulating fashion to channel incoming loads whilst improving balance.

The human physiology concerning the execution of the FAP is clearly relevant for the full understanding of the mechanics and physics lying behind this project concept. The movement of the human body for executing the FAP underlies in the orchestration of 200 muscles and seven types of skeletal joints. The joints limit the degrees of freedom for movement and rotation of bones

when the muscles pull them. Concerning the skeleton lateral balance, the most important function of all the joints is the rearrangement of the bones and, therefore, changing the body posture to another to relocate the center of gravity or COG (Horak, 2006). For a male body that weight 78.4 kg with a height of 1.76 m the COG in a quiet standing position locates inside the body at 95.5 cm from the ground and 8.4 cm from the forehead (Figure 1). During FAP-driven motion, the COG sways for controlling body-mass acceleration.

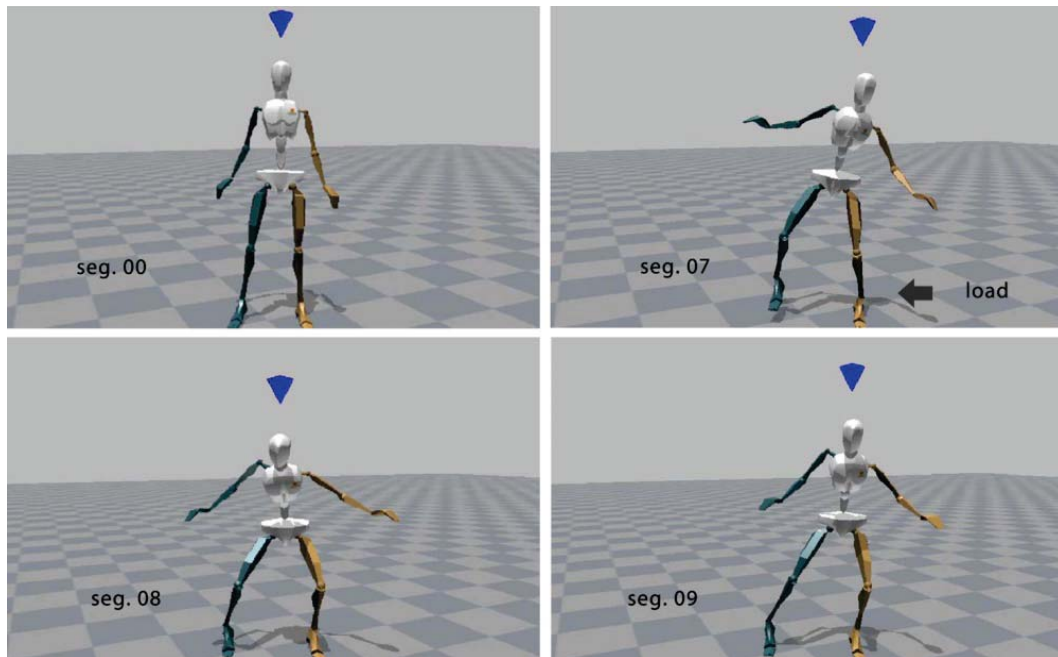

Figure 2. Human body fixed action patterns towards the channelling of lateral loads

To set up a sound hypothesis on the human FAP towards structural resilience, we tested 3 healthy adult subjects (1 female and 2 males; age range: 18-27 yr; weight: 59-81.6 kg; height: 1.7-1.8 m). Informed consent was obtained from each subject.

Different numbers of trials were conducted on each subject depending on the FAP we were analyzing at the moment. For all the trials, the subject was put through the dynamics of lateral forces, whilst being instructed to maintain balance throughout the test. The subject eyes were completely covered and they receive no cues as to if or when the perturbation would occur. To initiate the perturbation a strong impulse disturbance (a push) was applied in one of 8 subject contact points (left shoulder, right shoulder, chest, upper back, left hip, right hip, abdomen, lower back). After each push, the subject was allowed to adjust to an upright posture before being pushed again. A final test was performed where the subjects were put through base/ground lateral unidirectional motion.

All the tests were documented using video recording and, therefore, analyzed through observational means. Accordingly, based on the observational correlation between ground lateral forces and the human body FAP, we hypothesized that three general musculoskeletal reflexes in definite sequence towards the channelling of the loads take place (Figure 2). First, opening the legs to increase base of support and improve the channelling; second, crouch down to lower the COG and reduce the turning force; and finally, opening the arms to sum stability by counterbalancing the oscillations coming from the ground.



The proposed autonomous structure has been designed to be able to replicate the sequence of the human actions towards load channelling by mimicking the skeleton physiological motor engineering. Non-fixed steel elements shape the main structural components that reproduce the performance of large bones, while a series of universal joints mimics the actions of the skeletal saddle joints to rearrange the layout. Connecting both structural components with active beams, the structural layout becomes completely kinetic and able to imitate the required spectrum of biomechanical motion of the human skeleton. Synchronized electrical engines distributed across the building structure produce the necessary force to move the mechanical components and the architectural features. The engines are controlled by the computer software which has been directly inspired by the human FAP towards the channelling of lateral loads. Hence, the proposed autonomous structure mimics both the human skeletal components for the system kinetic capabilities, and the human instincts for the system artificially-intelligent behaviour that directs such actions.

## Electro-mechanical Architecture

The proposed electro-mechanical system has been designed to be controlled by computer algorithms based on artificially-intelligent behaviour able to mimic human fixed action patterns (FAP). But firstly, in order to manage the autonomous actions, the structure was engineered replicating several skeletal features into mechanical components so it would be able to reproduce the human body biomechanics. Translating the biological features into building elements was a challenge of tectonic performance and mechanical engineering.

Since the main concept addressed for this project frames a responsive architecture able to quickly adapt to sudden environmental stimuli, the primary considerations for the structural design were lightness and force. Hence, steel was materiality's main option to be used for the components in the autonomous structure. Steel allows for the necessary ductility while minimizes the overall architectural weight. Also, steel components are easier to move through means of electrical engines while being structurally sound to withstand great tensile and compressive forces. Thus, the steel components can move fast enough to adapt the building structural layout to the incoming seismic loads in real-time.

The steel tectonic of the proposed system also allows for modular engineering based on existent components such as steel tubes and metal universal joints. Though some of the joints were specially engineered following the system's performance, most of the components are well known in the construction industry. This feature allows for the easiness of the customizability for different building sizes and typologies. However, the system's prototype was engineered following parameters of human anthropometry, affordability and standardization.

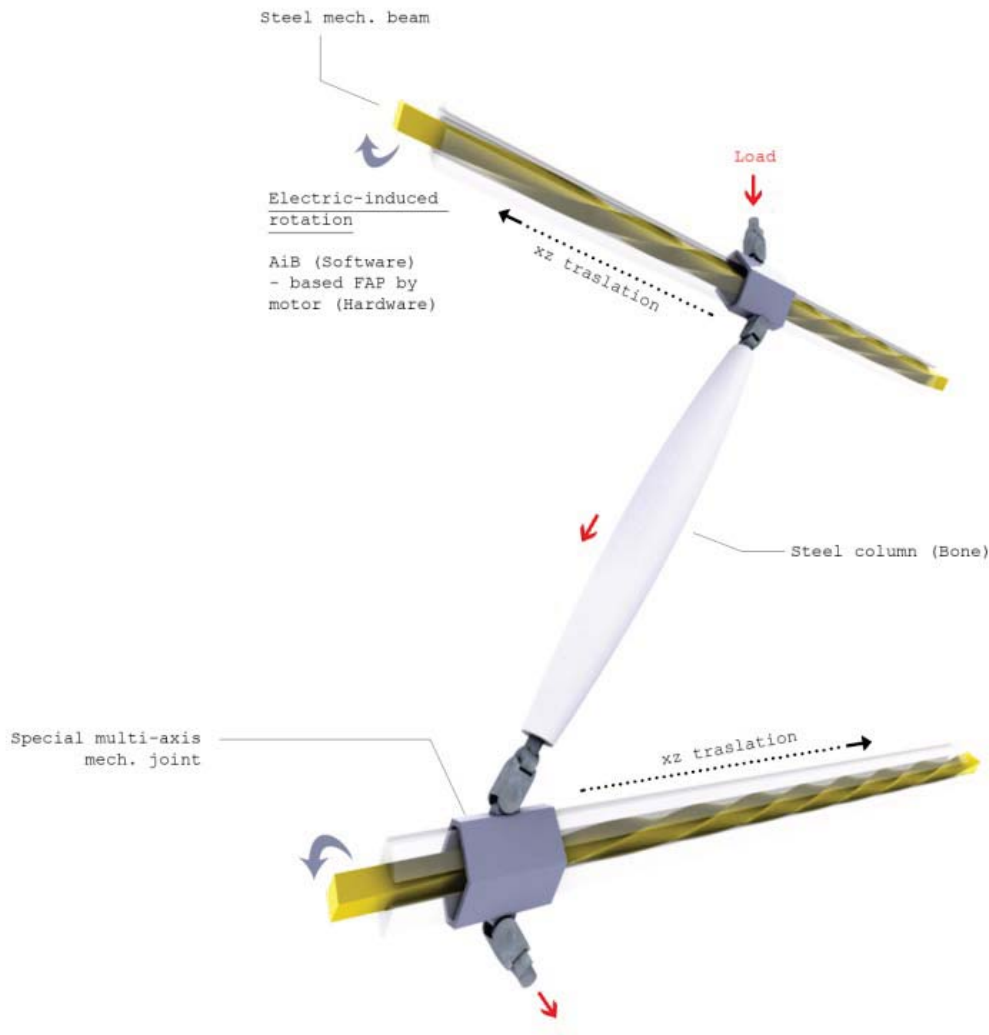

Figure 3. Mechanical components of the autonomous seismic-controlling structure

The prototype design is based on moment resisting frames since they are the most common frames among buildings in developing countries where the seismic hazard is higher. The modular frame has been proportioned to accommodate two floor plates. Each frame is composed by two rotational steel threaded-beams vertically connected with two hydraulic elements at both ends. In addition, a steel tubular column also connects to the beams throughout a special joint able to move along the beams from one extreme to another. Hence, the steel tubular column is not entirely fixed since it can move and shift the angle following the joint that is managed by the rotational threaded-beam (Figure 3). Each beam uses an electrical engine to power the motor actions of the mechanical joints and, thereby, changing the load vectors of the layout in order to improve the structure performance.

When the engine makes the threaded-beam to rotate, it produces the joint to run along the beam axis. The engines are synchronized with the system's software controlling the reactions. That

way, the joints can change the channelling of the structural loads by shifting the layout design. Since the joints have the freedom to move towards the beam extremes, they can change the position and the angle of the tubular columns from a typical moment frame into a diagrid for instance. Though the structure actuates in the horizontal axis, it is always performing within the module limits, thus the module doesn't change its horizontal dimensions. Neither the building changes its position in the site nor moves out of its layout limits, therefore can be located in dense urban zones without the risk of threatening surrounding structures. However, the system has been engineered to transform the vertical dimensions. As the human body, the structure crouches down to lower the COG and reduce the turning force produced by the lateral loads (Abu-faraj et al., 2008).

A major challenge for this kinetic structure was the transformation from the initial morphology into another while being structurally sound throughout the full sequence. The sequence aims to mimic the main musculoskeletal reflexes and its structural benefits: increase base of support, improve the load channelling, reduce the turning force, and counterbalancing the oscillations. While being in movement, the electro-mechanical structure faces eccentric forces that are also managed by the local components. Essentially, the structure FAP seeks to minimize as fast as possible the building period of free vibration that is induced by the earthquake lateral loads.

The motion of the electro-mechanical structure is accomplished by a series of synchronized engines that emulate the orchestration of the human body skeletal muscles. Since they are distributed in the overall building structure, there is no single engine to carry the entire building weight. At the contrary, the distribution of engines across the structure also distributes the weight per structural module and its engines. The engines torque and speed are controlled by the computational software based on our algorithm that simulates human capability to re-distribute the channelling of the lateral loads. The electro-mechanical structure main configurations shift from the initial resisting moment frame into an irregular braced frame combining concentric, semi-concentric and eccentric bracing, and finally into a self-stabilizing space frame that triangulates the structure morphology. The braced frame system scale depends of the intensity of the building's fundamental period of free vibration. The more intense the structure swing, the bigger becomes the diamond grid until the structural layout turns into a space frame.

## Seismic-controlling Structural System

Major earthquakes can cause a lot of hazardous actions to buildings. For building designers, the main focus is on the effects induced in the building structure by the vibratory movements of its site. Common harmful factors about earthquakes are the speed with which the seismic movement occur, plus the rapid reversals of direction that cause a violent shaking (Ambrose & Vergun, 1999). Combined, these factors can be disastrous for the building. A building's response to an earthquake is related to various properties of the building structure. The main ones are the building mass and its fundamental period of free vibration (Somasekharaiah et al., 2008). The proposed autonomous structures decrease the building mass due to its steel tectonic and are also able to minimize its fundamental period of free vibration by mimicking the human body actions to adapt the morphology to the incoming loads.

The proposed structural system was engineered based on steel frames to generate a lightweight structure and minimize the building mass. Steel frames are highly suitable construction systems since they can be assembled very fast and easy (Somasekharaiah et al., 2008). However, steel moment frames have demonstrated to be very vulnerable to cyclic motion that increases base shear and produces buckling (Elsesser, 2004). This system has collapsed in the past during large earthquakes. The human-inspired seismic-controlling structure has been engineered mainly as a self-stabilizing steel braced frame with active hydraulic columns that act as dampers to absorb cyclic motion and the compressive forces that produce buckling in steel frames. At the other hand, since the system is made of lightweight components that would be assembled into high-rise buildings, they can be



threatened by large periods of free vibration. Nevertheless, the autonomous structure main function is to cancel the fundamental period of free vibration by actively transforming the building structural morphology and, thus, counteracting the horizontal loads in real-time. To transform from one frame type into another, the autonomous structure performs based on a computer algorithm that emulates human behaviour towards balance.

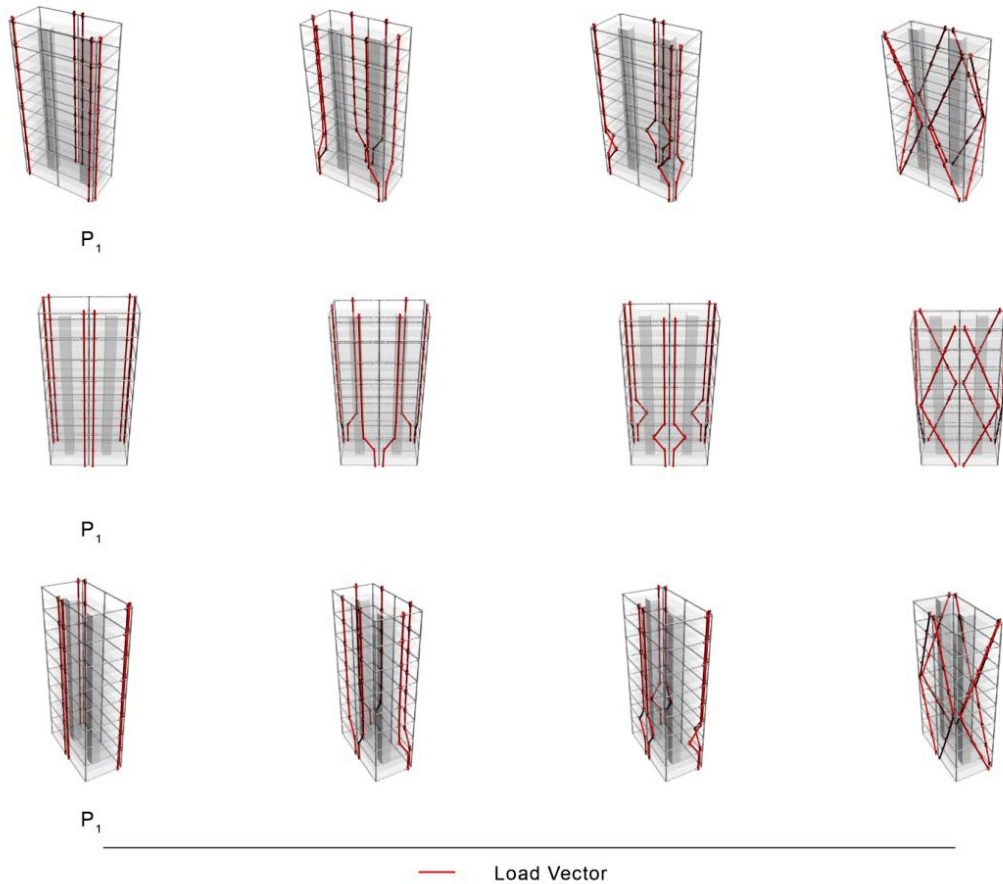

*Figure 4. Structural layout transformation of the autonomous seismic-controlling structure*

The proposed electro-mechanical structure is able to replicate the main human strategies for minimizing the lateral loads effect on the skeleton. The structure can transform the gravity-driven moment frame into a braced frame to mimic the separation of the foot that increases base support and improves channelling. Also, the structure morphology decreases its height as an analogue to the human crouching action to minimize the turning force. Such active behaviour would improve the building stability during diverse earthquake loads, direction, acceleration and period of the motion.

## Conclusions

Combining biomechanics with the principles of artificial intelligence, the proposed autonomous structure addresses the engineering of an electro-mechanical structure with artificially-intelligent behaviour able to actively counteract hazardous lateral forces from major earthquakes in real time. The proposed solution will reengineer the concept upon which seismic resilience is grounded by generating structures to behave like human beings to protect people from large earthquakes. The autonomous structural systems will quickly channel the incoming seismic loads by actively rearranging the structural layout in real time, therefore, adapting to the forces by the same rules governing the human skeleton resilient principles.

This project aims to foster a more accurate definition for the concept of smart buildings by mimicking human biomechanics and even the human primitive intelligence to control its skeleton. Moreover, the project seeks to upgrade the resilience of vulnerable structures by emulating a biological model that goes beyond mitigation when adapting and responding to environmental inputs. This technology puts buildings in a whole new level where they are no more just inert structures but will rather be considered as intelligent and responsive agents.

## References

- Abu-faral et al., "The Study of Postural Stability in an Earthquake-Simulated Environment", *Journal of Biomedical and Pharmaceutical Engineering*, vol. 2, issue. 1, pp.14–21, 2008.
- Ambrose, James; Vergun, D., *Design for Earthquakes*, John Wiley & Sons, Inc., New York, 1999.
- Chey, Min-Ho; Mander, J.B.; Carr, Athol and Geoffrey, J., *Multi Story Semi-Active Tuned Mass Damper Building System*, Keimyung University, 2006.
- Desroches, R. & Smith, B., "Shape memory alloys in seismic resistant design and retrofit: A critical review of their potential and limitations", *Journal of Earthquake Engineering*, vol. 7, issue 3, pp. 2005–2006.
- Eatherton, M.R. et al., "Design Concepts for Controlled Rocking of Self-Centering Steel-Braced Frames", *Journal of Structural Engineer*, vol. 140, issue.11, pp. 1-11, 2014.
- Elghazouli, Ahmed Y., *Seismic Design of Buildings to Eurocode 8*, 2009.
- Elsesser, E. & Engineers, F.E., "Seismically Resistant Design – Past, Present, Future", *13th World Conference on Earthquake Engineering*, California, 2004.
- Frenay, R., *Pulse: The Coming Age of Systems and Machines inspired by the Living Things* 1st ed., Farrar, Straus and Giroux, New York, 2006.
- Herrnstein, R.J., "Nature as Nature: Behaviorism and the Instinct Doctrine", *Behaviorism*, vol.1, issue.1, pp.23–52, 1977.
- Heysami, A., "Types of Dampers and their Seismic Performance During an Earthquake", *Current World Environment*, vol.10, issue. 1, pp.1002–1015, 2015.
- Horak, F.B., "Postural orientation and equilibrium: What do we need to know about neural control of balance to prevent falls?" *Age and Ageing*, vol. 35, issue 2, pp.7–11, 2006.
- Islam, A.B.M.Saiful. et al., "Seismic Base Isolation for Buildings in Regions of Low to Moderate Seismicity : Practical Alternative Design", *Practice Periodical of Structural Design and Construction*, vol.17, issue 1, pp.13–20, 2012.



Kamrava, A., "Seismic Isolators and their Types". *Current world environment*, vol.10, issue 1, pp.27–32, 2015.

Palmieri, R.M. et al., "Center-of-Pressure Parameters Used in the Assessment of Postural Control", *Journal of Sport Rehabilitation*, vol. 11, issue. 1, pp. 51–66, 2002.

Sabelli, R., Mahin, S. & Chang, C., "Seismic demands on steel braced frame buildings with buckling-restrained braces", *Journal of Engineering Structures*, vol. 25, issue.5, pp. 655–666, 2003.

Sawaguchi, T. et al., "Design Concept and Applications of Fe–Mn–Si-Based Alloys—from Shape-Memory to Seismic Response Control", *Materials Transactions*, vol.57, issue.3, pp.283–293, 2016.

Somasekharaiah, H.M. et al., "A Comparative Study on Lateral Force Resisting System for Seismic Loads", *International Research Journal of Engineering and Technology*, vol. 3, issue 8, pp. 1138–1144, 2008.

Sonawane, Y.N., "Base Isolation for Multistoried Buildings with Lead Rubber bearing", *International Journal of New Innovations in Engineering and Technology*, pp. 29–33, 2016.

Yoshioka, H., Ramallo, J.C. & Spencer, B.F., "Smart Base Isolation Strategies Employing Magnetorheological Dampers", *Journal of Engineering Mechanics*, vol. 128, issue 5, pp.540–551, 2002.

## Between The Shadow And The Geometry Of Light

Hestnes Ferreira in continuity with Louis Kahn

Alexandra Saraiva

*ISCTE, Dinâmica CETIUL, Universidade Lusíada Norte- Porto, Portugal*

*ambac@iscte.pt; saraivaalexandra@gmail.com*

**Abstract.** This paper intends to show the relevance of light in the work of Louis Kahn and in the work of Hestnes Ferreira in formal and perceptive terms. Raúl Hestnes Ferreira (Lisbon, 1931) is a Portuguese architect who had the privilege of studying and working with Louis I. Kahn between 1963 and 1965. Light, although an external and contingent element of architecture, is a decisive element in terms of definition and perception. Therefore, four works by each architect are compared and analyzed. The results help to highlight the importance of light and shadow in the determination of architectural spaces and how silence enhances the perception of Hestnes Ferreira and Louis Kahn spaces.

**Keywords:** *Light; Shadow; Hestnes Ferreira; Louis Kahn.*

### Introduction

Light is a term with a vast number of meanings which has always been the target of constant reflection by art history, philosophy, and aesthetics.

The expressiveness of an architectural work is directly related to the concept of light, as the play of light and shadow can manifest the formal composition and the perception of a particular architectural space. Although the architectural space depends on a delimitation and physical measurement, the reach of its perceptive presence 'is greater than its materiality' (Pinto, 2007, p.23)

The paper is developed in two moments: the light and shadow as elements that delimit and / or shape the space; and the silence as a result of the perception that each user has about that same space.

The methodology used is a presentation of a comparative analysis between Louis Kahn and Hestnes Ferreira and four buildings by each one. Thus, for the work by Louis Kahn, we have used the research 'typology of light control' by Urs Büttiker (1993) and which resulted in a similar analysis on the work by Hestnes Ferreira, which I developed during the research for my PhD. (Saraiva, 2011)

By Louis Kahn, the Yale University Art Gallery (1951-53) in New Haven; Salk Institute (1959-65) in La Jolla, California; The Phillips Exeter Library (1965-72) in Exeter, New Hampshire; the Kimbell Art Museum (1966-72) in Fort Worth, Texas. By Hestnes Ferreira, the Beja Youth Culture Centre (1975-85) in Beja; José Gomes Ferreira Secondary School (1976-80) in Lisbon; the Bento Jesus Caraça Library (1989-97) in Moita; the Caixa Geral de Depósitos (1985-91) branch in Avis

### Purpose

The main purpose of this research is to understand light and shadow as decisive elements in the creation of architectural spaces. As well as introduce the concept of silence, so often mentioned and defended by Louis Kahn as a decisive factor in the perception of these same spaces.

Another objective of this research, which has been proven in my doctoral thesis, is to prove how Hestnes Ferreira designs in continuity with Louis Kahn.



## State of the Art

Louis Kahn presented a conference entitled *Silence and Light* February 12, 1969, at the Architecture School of the Swiss Federal Institute of Technology in Zurich. This conference was later published and it is mandatory for anyone intending to understand the binomial light and silence according to Louis Kahn. (Latour, 2003, pp.244-257)

The conference 'Architecture: Silence and Light' was held on December 3, 1968, at the Solomon R. Guggenheim museum, and was subsequently published in 1970 by the Guggenheim Museum, *On the Future of Art*. (Latour, 2003, pp.260-267)

For Louis I. Kahn, light would become a fundamental element in the creation of the architectural work - a creative element by its very nature; a presence-creating element. There are three emblematic phrases that contribute greatly to the construction of the theme of light in his work: "A building begins with Light and ends with shadows", and "The sky is the roof of a square" and "A room without natural light is not a room."

As Alessandra Latour (2003) states, I also consider that for Louis Kahn, words had the same power as his drawings and works in conveying images about the conception of the world and philosophy.

Urs Büttiker (1993, p.39) defined seven modeling elements (curtain; northern light, direct light, broken light, horizontal movable pannels, vertical movable pannels, leaf for ventilation) and the corresponding symbology in order to compare and systematize forty-nine works by Louis Kahn. This research was undoubtedly an added value for the understanding and systematization of the importance that light had for the work produced by Louis Kahn.

For Giurgola (1981) Louis Kahn's professional career is marked by a constant search for the essence of architecture through five constants that are repeated throughout his works: the composition and integrity of the building; respect for materials; the spatial module as the basic element, where repetition determines the design; light as a constructive factor; and the relations between the different architectural elements.

Leland M. Roth underlines the importance that Louis Kahn assigns to light 'it has the property of creating powerful, psychological responses and contains a precise psychological effect' (2005, p.77).

António Juaréz states that Louis Kahn 'associates light with a colour, a predominant tonality of the reflections of the materials' (2006, p.89) always taking into consideration materiality with something that cannot be dissociated from space.

Louis Kahn's concern was defended many years later by Campo-Baeza who considered the duality between matter and material. This search had already been felt and proclaimed by Kahn, both in his writings and conferences, as well as in his works. 'Light is matter and material (From the materiality of LIGHT)' (Campo-Baeza, 2004, p.15).

Hestnes Ferreira also shares the same references as Louis Kahn, as in his works, the control and the presence of Light is one of the most important and significant points in his way of designing and constructing, '*..light, for me, is fundamental; it is the spatial key of a building. I can assert that there are two types of light, one that guarantees functionality of space, and the secret light that gives spaces, especially those most hidden, the effect of the unexpected.*' (Saraiva, 2011, p.302).

## Between Light and Shadow

Natural light sees its importance increased in terms of architecture from the 1950s and 1960s onwards, as a result of new methods of construction and greater architectural freedom.

But, like any natural element, light is not a constant and static element, it depends on the light source, the geometry, the planes it is focused on, and lastly on the observer. When we refer to the source of light, we are in some ways specifically analyzing three elements: its intensity, the directional characteristics and, finally, its colour. Geometry always depends on the relationship that

is created between the light source and the illuminated plane. Thirdly, the planes where the light is focused - taking on a dual category of receiving and modifying light - can, through reflection, even become secondary sources of light by the way they redirect and alter the colour of light. And lastly, the most important factor - the observer - without him the reading and perception of the light would not be possible.

Louis I. Kahn described Architecture as the creation of spaces by the shaping of light. And this shaping includes the dialogue of light as a close relationship between duration and time, specifically between sunshine hours and seasons. It is also influenced by the shape and orientation of the openings and how the space is illuminated by a solid or diffused light.

In addition to the previous issues, we must also emphasize that light has to be analyzed in two distinct ways: inside and outside the architectural work. The appreciation of light in the interior is evidenced by the relation between solar trajectory and the valuation of specific elements existing in the interior space. While on the exterior of the building, so as to highlight the shape, the composition strategy uses the contrasts of light, shadow, and half-shadow.

Solid light produces a high degree of illumination, while producing well-defined light and shadow patterns. On the other hand, diffuse light, although less intense, remains constant and balances the light level in the space. Always bearing in mind the profound difference between external light - which shapes the volume, and the internal light - that gives life to the spaces that the volume itself contains.

## Vertical Light

Vertical light has a strong and constant presence in Louis Kahn's work. The use of this type of light depends, partly, on the interpretation and symbolism that the author intended to obtain in each interior space. Hestnes Ferreira shares the same anxieties and aims to achieve the same result in his works.

The interpretation of light, by Kahn and by Hestnes, goes against what the West defends by not focusing the light directly on an object, or on a space; instead designing so as to ensure an indirect light, which provides a controlled reflection, more specifically empowering the shadow.

The way these two architects capture the vertical light makes them stand out from others: by defining a specific shape and dimension, they condition the geometry of each opening.

The vertical light, used by the two architects, considers two possibilities and, consequently, determines two distinct well-lit spaces. First, when they associate it with large-scale interior spaces, allowing for the projection of the light beam to be enlarged in interior spaces; and second, when they decrease the size of the opening, they direct and intensify the light beam, increasing the luminous concentration on one point.

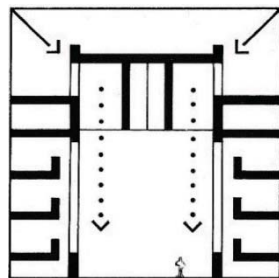

Figure 1. Philip Exeter Academy, Library

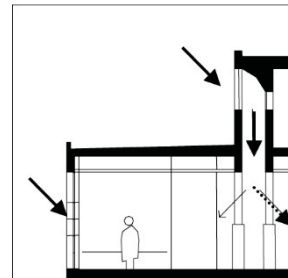

Figure 2. Caixa Geral de Depósitos, Branch



Louis Kahn, in the library hall [FIGURE 1] and Hestnes Ferreira, in the main public space of the Caixa Geral de Depósitos branch [FIGURE 2], improve the light possibilities of these spaces by using vertical wall bays.

The zenithal lighting proposed by Hestnes Ferreira between the two white concrete beams aims to illuminate the interior emphasizing 'the importance of the white concrete that lightly frames the light on the central counter, in contrast to the weight of the brick masonry that defines the building.' (Ferreira, 2012, p.127) These elements as a consequence of the size, shape, and material of the opening, increase the light capacity of these spaces and provide a more intense perception of these spaces.

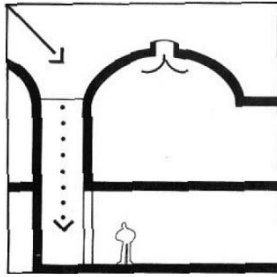

Figure 3. Kimbell Art Museum

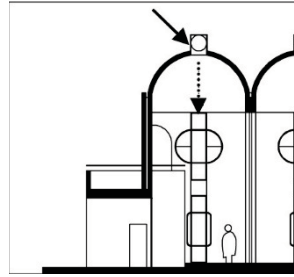

Figure 4. Beja Youth House

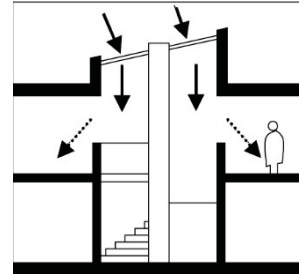

Figure 5. José Gomes Ferreira  
Secondary School

The exhibition space at the Kimbell Museum [FIGURE 3], the central space at the Beja Youth Cultural Center [FIGURE 4] and the vertical accesses at the José Gomes Ferreira School building [FIGURE 5], the latter by Hestnes Ferreira, illustrate the second type of space, where the shape and size of the opening intensify the light beam, while increasing the concentration of luminosity at a given point. These characteristics present the user with a perception of the differentiated space, whether it is in the shadow or in the illuminated space.

## The diagonal light

The diagonal light is the most used in North American and European architecture when compared to the light used by other non-Western cultures. Usually this type of light is the one that has the most influence on the spaces, allowing for a more efficient reading of the sunshine hours and the season of the year. This forces architects to design other elements associated with these openings. In the background, the purpose of these elements is nothing more than the control of the exposure and the light intensity of these spaces.

Louis Kahn associates this type of light to two different procedures: the first maintains the opening in the facade plane and introduces other elements of control of intensity; the second retracts the opening in regards to the facade plane.

Similarly, Hestnes Ferreira adopts these two procedures in a very interesting way, adapting the Portuguese constructive reality, as well as the materiality that characterizes the nation.

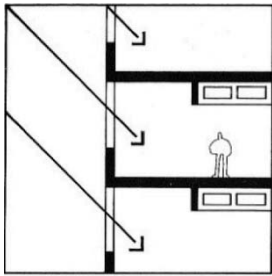

Figure 6. Salk Institute for Biological Studies

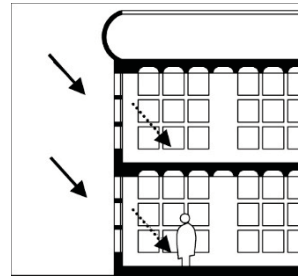

Figure 7. José Gomes Ferreira Secondary School

In these two examples [FIGURE 6] and [FIGURE 7] regarding work spaces in the Salk Institute for Biological Studies, as well as in the classrooms of the José Gomes Ferreira School, the size and positioning of the opening in relation to the facade limit the projection and control the intensity of light within each space.

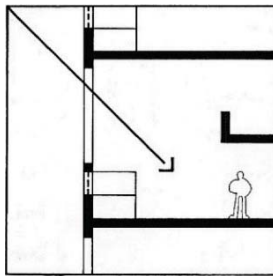

Figure 8. Philip Exeter Academy, Library

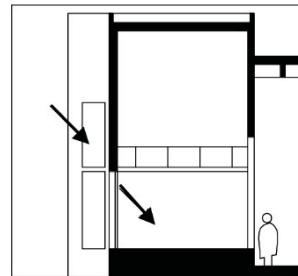

Figure 9. Bento Jesus Caraça Municipal Library

Louis Kahn, at the Exeter Library [FIGURE 8], designs two types of openings in the facade plane, a smaller one, which limits and concentrates the light on the individualized reading area, and a larger one that spreads and projects the light in a wider area.

At the Bento Jesus Caraça Municipal library [FIGURE 9], Hestnes Ferreira designs more contained openings so as to avoid constraints in terms of the incidence of light over the area of the stage.

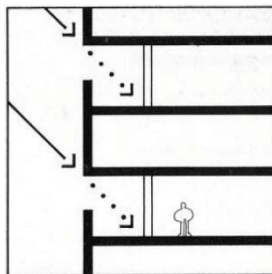

Figure 10. Salk Institute for Biological Studies

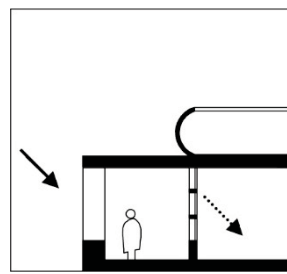

Figure 11. José Gomes Ferreira Secondary School



In the Salk Institute [FIGURE 10], when the glass plane recedes from the plane of the facade, Louis Kahn is able to obtain illuminated spaces, but with the best control over the intensity projected in that space.

At the José Gomes Ferreira Secondary School [FIGURE 11], Hestnes, when designing a pergola, introduces a transition space. Allowing the opening to be more restrained and the light reflected over the classroom space in an even more continuous and harmonious manner. I named this type of solution the 'membrane wall' (Saraiva, 2011, p.174)

After analyzing all the schemes, we were able to find the same concerns and similar solutions for the resolution of the incidence, type, and quality of light intended by both architects. The expression so often mentioned, - Without light there is no architecture -, shows an extreme validity in the work of both architects. The added value is directly related to the perceptual effect produced by users of the spaces.

## Silence and Light

'Silence and Light' is a binomial created by Louis Kahn around the time of the middle of his career and it prevailed until the end. For Kahn, the immeasurable is the force that drives the creative spirit toward the measurable, the Light. Therefore, it establishes the relation between these two concepts; silence represents what does not exist and light represents what does.

The principles of harmony and proportion were visible at the design stage, but the perception was only visible once the work was completed. Consequently, 'if what is drawn is precise, what is built should be precise [too]' (Gast, 2001, p. 11)

Hestnes Ferreira never spoke explicitly regarding the concept of silence, but we can draw an analogy with the definition given by Louis Kahn. Hestnes's architecture is characterized by homogeneous spaces, valued by light and materials. Silence in his works can be translated by the simplicity and neutrality of spaces, realized by the absence of ornamentation and by the simplicity and clarity of shapes. The determination of silence results from design strategies, where we can include: membrane walls, light, simple shapes, scale, and materials. The combination of these strategic elements determines and appeases correct acoustic enclosures, while at the same time stimulating our perception. The perception of architecture is more assertive and subtle when the senses (vision and hearing) work together in harmony.

The nature of his works [Hestnes Ferreira] is defined by a triad: the openings that receive and transmit light; the materials - decisive elements for the characterization and that have different levels of presence and express the way the buildings interact with the Place; and finally the resulting colour.' (Saraiva, 2011, p.175)

## Conclusion

Louis Kahn and Hestnes Ferreira, as we were able to validate by the analysis of our schemes in relation to those of Urs Büttiker, use vertical light by the amplitude and the capacity of their reflection on space, usually in spaces of greater size or of a more public nature; while diagonal light, being a more contained light, is used in smaller spaces or of a more private nature with the distinct aim of filtering the light, and in some cases using the inclusion of external vertical or horizontal elements.

For Louis Kahn, light was one of the key architecture elements, its interpretation and use transcended the typical relation: matter and shape. His ability to understand and build according to the light allowed him to combine human experience and spiritual ideals. Light and shadow reveal the building: its spaces, its shapes, and its meanings.

Hestnes Ferreira has the same ability as Louis Kahn regarding the interaction with light, designing spaces with a unique nature. Each opening is defined by its location and results from a

deep knowledge of light. The type of opening, as well as the source of incidence chosen by both, reflects the same approach. Hestnes Ferreira, while analyzing some of his own works, wrote the following 'the dialogue of materials is also the dialogue of light.' (2012, p.130). We can even say that light is defined by the material that frames it according to the spaces it illuminates.

Silence, in the works by Kahn and Hestnes, can be translated by the simplicity and neutrality of spaces, realized by the absence of ornamentation and by the simplicity and clarity of shapes. The architecture of both is characterized by homogeneous spaces, valued by light and silence.

Hestnes Ferreira does not, just as Louis Kahn did not, design according to the commercial use of stylistic approaches, nor according to the majority of them, but can, with the repetition of certain elements, create a registered trademark and distance himself from the Portuguese national perspective. Considering a unique authenticity, the course depends on the continuous search for the essence of architecture.

## Acknowledgments

I would like to thank the architect Raúl Hestnes Ferreira for his availability and for providing me with all the necessary material, as well as for all his support throughout the research process.

Supported by FCT grant (SFRH/BPD/111869/2015)

## References

- Büttiker, Urs, Louis I. Kahn: Light and Space, Birkhäuser, Basel, 1993.
- Campo Baeza, Alberto, A Ideia Construída, Coleção Pensar Arquitectura, Caleidoscópio, Lisboa, 2004
- Ferreira, Raúl Hestnes, "CONHECER O TIJOLO PARA CONSTRUÍR A ARQUITECTURA", in Lourenço, P.B. & Sousa, H. (Eds.), Seminário sobre Paredes de Alvenaria, pp. 111-132, Porto, 2002.
- Gast, Klaus P., Louis I. Kahn: The Idea of Order., Birkhäuser, Basel, 2001
- Giurgola, Romaldo, Mehta, Jaimini, Louis I Kahn, São Paulo, Martins Fontes, 1981
- Juárez, António, El Universo imaginario de Louis I. Kahn, Colección Arquithesis núm. 20, Fundación Caja dos Arquitectos, Barcelona, 2006
- Latour, Alessandra, Louis I. Kahn. Escritos, Conferencias y Entrevistas, El Croquis Editorial, Madrid, 2003
- Lobell, John, Between Silence and Light: Spirit in the Architecture of Louis I. Kahn, Shambhala, Boston, 2008.
- Pinto, José C., O Espaço Limite: Produção em Arquitectura, Lisboa, ACD Editores, 2007
- Roth, Leland M., Entender la Arquitectura: sus elementos, historia y significados, Editorial Gustavo Gili, SA, Barcelona, 2005.
- Saraiva, Alexandra, A Influência de Louis I. Kahn na obra de Hestnes Ferreira, Tesis doctoral, Universidade da Coruña, 2011.

## Figure Credits

Figure 1\_ Philip Exeter Academy, Library (Büttiker, 1993, p.139)



Figure 2\_ Caixa Geral de Depósitos Branch (Saraiva, 2011, p.217)

Figure 3\_ Kimbell Art Museum (Büttiker, 1993, p.145)

Figure 4\_ Beja Youth Cultural Centre (Saraiva, 2011, p.218)

Figure 5\_ José Gomes Ferreira Secondary School (Saraiva, 2011, p.218)

Figure 6\_ Salk Institute for Biological Studies (Büttiker, 1993, p. 111)

Figure 7\_ José Gomes Ferreira Secondary School (Saraiva, 2011, p.220)

Figure 8\_ Philip Exeter Academy, Library (Büttiker, 1993, p.133)

Figure 9\_ Bento Jesus Caraça Municipal Library (Saraiva, 2011, p.220)

Figure 10\_ Salk Institute for Biological Studies (Büttiker, 1993, p.111)

Figure 11\_ José Gomes Ferreira Secondary School (Saraiva, 2011, p.221)

## Translating Algorithmic Design from CAD to BIM

Renata Castelo Branco<sup>1</sup>, António Leitão<sup>2</sup>

<sup>1,2</sup>*INESC-ID, Instituto Superior Técnico, Universidade de Lisboa, Portugal.*

<sup>1,2</sup>*{renata.castelo.branco | antonio.menezes.leitao}@tecnico.ulisboa.pt*

**Abstract.** Nowadays, practitioners are embracing the BIM paradigm, as it allows a faster development of models using pre-modeled elements and automates time-consuming tasks such as the production of technical documents. Nevertheless, CAD tools still provide greater freedom in form creation, which is better suited for the early and exploratory stages of the project. To take advantage of both approaches, some practitioners begin designing in CAD environments and, when satisfied with the overall shape, transition to BIM. This paper addresses the in-between stage of this transition from an Algorithmic Design standpoint. It explains the main differences between the two paradigms and proposes a modeling methodology, using a portable algorithmic design tool capable of generating the building's design in both CAD and BIM software, which facilitates the translation process of the building's description from one paradigm to the other.

**Keywords.** CAD; BIM; Algorithmic-based Design.

### Introduction

Architectural design has seen many changes over time, and more so over the past few decades, namely regarding the representation methods used in its process (Kalay, 2004). After centuries of sketches and hand-made technical drawings, perspectives, and models, the representation archetype changed with the introduction of Computer-Aided Design (CAD) software. Further along, another shift occurred with the spread of Building Information Modeling (BIM), hailed as one of the most promising developments in Architecture, Engineering and Construction (AEC) industries (Eastman, et al., 2008), replacing the two-dimensional conception of projects into a fully three-dimensional representation workflow.

Parallel to these advances, an entirely different manner of conceiving architecture has been pressing forward behind these applications: Algorithmic Design (AD), a computational approach to architectural design. AD allows the user to create forms through algorithms (Terzidis, 2006), describing the shapes through a series of rules and constraints. Recognizing the advantages presented by this approach, many tools were created to support the development of AD programs, firstly within the CAD paradigm, and, more recently, within the BIM paradigm as well.

Both CAD and BIM paradigms have appeared in response to specific needs that have arisen over time. This means that both paradigms present distinct advantages to the modeling process, and the two have set their own role in the architectural agenda. Most practitioners are embracing the BIM paradigm, as it not only accelerates the modeling process with the use of pre-modeled elements, but also automates time-consuming tasks, such as arranging maps of quantities and costs. Nevertheless, CAD tools, as free-form surface modeling tools, provide greater freedom in form creation (Zboinska, 2015), which may justify a preference in developing the early stages of the project in these applications, such as form and concept experimentation. This paper addresses the in-between-paradigms stage of an architectural design process based on Algorithmic Design.





## Algorithmic-based Design

AD allows the modeling of complex geometries that would pose challenges to a normal mouse-based approach. An AD approach entails a parametric modeling philosophy, meaning that the design can be manipulated through parameters. Multiplicity of scalar parameters (Meredith, 2008) offers a degree of freedom to design that cannot be achieved by simply using the software as it is provided to the common user. Hence, AD allows the architect to explore a wider range of possibilities with less effort than a mouse-based approach. Furthermore, it allows the user to go beyond what the tool's manufacturers intended, converting the normal tool-user into a tool-maker (Burry, 2011).

Besides transcending the limitations modeling tools might impose on their users (Terzidis, 2006), algorithmically describing buildings' designs is also proving to facilitate the transition between paradigms. Algorithmic descriptions, as mathematical abstractions of the design intent, possess portability qualities that transcend software particularity. Portable AD tools already available in the market are capable of connecting to both CAD and BIM applications. However, the two paradigms still require architects to model using different operations, and consider different sequences and methods for each archetype. The following sections address some of these differences.

### Two different paradigms

Programming for CAD tools is more advantageous in an initial stage of the model, as these tools present a better performance when compared to BIM tools. CAD programs can generate geometry faster, since they do not deal with the semantics inherent to BIM objects. For this reason, an architect can test a wider range of solutions for his design in a shorter time span. Furthermore, not only do they allow for the generation of more complex geometries that some BIM tools cannot process, but they also enable a constraint free modeling workflow, where no sequences or precedents are imposed.

BIM tools require the user to model an accurate virtual model of his design, from which technical drawings, like plans and sections, are automatically generated and updated whenever the model undergoes changes. Unlike a CAD model, that contains only the modeled geometry, BIM embeds the model with data needed to support construction, fabrication, and procurement activities (Eastman, et al., 2008). This means that, besides plans and sections, the programs are also capable of automatically elaborating other technical elements for construction management, such as quantity and cost charts.

When the project enters a phase of greater detail, shifting the scripting task to the BIM paradigm has proven to reduce the time and effort spent on the modeling process. In a BIM environment, the architect can take advantage of all the information available in the families or libraries, saving a lot of time, as he needs not to algorithmically model every single geometric element from scratch.

As each archetype better fits a specific stage of the design process, transitioning from CAD to BIM in the midst of a project is becoming more and more common. To this end, users may try importing the models generated in CAD into BIM tools, but the results are seldom satisfactory. BIM tools recognize the geometry created in CAD, yet they rarely succeed in embedding them with the right semantics. Hence, even if the geometry is successfully imported, its elements may still not be recognized as BIM objects. As a result, architects may end up having to rewrite the entire description of the model from scratch. This paper addresses a transition process with no model imports or exports. Instead, we promote a conversion of the scripted model for CAD applications to one capable of producing equivalent building elements in BIM applications.



There are several examples of projects that faced this need for translation. The Aviva Stadium began using McNeel's Rhinoceros platform for the architects to quickly explore the stadium's geometry, which was later rebuilt within Bentley's Generative Components (Shepherd, et al., 2011). The Shanghai Center project and Hangzhou Olympics Stadium are two other examples. Both were initially generated in Rhinoceros, using Grasshopper, for parametric design of the mass and the skin of the buildings, and then translated into BIM (Autodesk Revit) for detailed design and construction (Kensek & Noble, 2014).

## Lessons learned regarding translation processes

Assuming the architect begins scripting his design in a CAD environment, so as to take advantage of a constraint-free workflow, and further along the process transitions to the BIM paradigm for a more detailed phase of the model, we propose a methodology for the transition stage between the two. This methodology focuses on Algorithmic Design and presents a set of rules for the conversion of a scripted design thought to be generated in CAD, into a rationalized concept that can be modeled with BIM objects. The following paragraphs expose the main challenges posed by the translation process.

While modeling for CAD, the architect can explore his design concerning himself with geometry only. Hence, taking advantage of the modeling operations that create geometric shapes, like circles and boxes, and that apply geometric transformations, including translations, lofts, extrusions and sweeps, he can explore several variations to the form of the various elements that compose the building.

When transitioning to BIM, the user must consider other aspects beyond geometry modeling. Namely, sequential arrangements of the elements according to construction logic, object semantics, and additional information. The BIM paradigm intends to facilitate the modeling task for the architect through the given pre-modeled objects, while restricting his modeling to buildable realities. All elements created must belong to a building category, with a specific role in the building's structure, such as slabs, columns, beams, roofs, doors, windows, among others.

Furthermore, when modeling for BIM software, users are obliged to follow a specific order of modeling. While in CAD the user may model, for instance, doors or windows anywhere in space with no precedence needed, in BIM these elements cannot be created if a wall to host them is not provided first. Other impositions are present in the modeling operations, for instance the need to define levels, used as reference for the location of all elements.

As part of the transition process, we propose modeling in CAD having in mind intermediate abstractions that might help overcome some of the translation issues. These abstractions are implemented by the user on his program, using operations to model in CAD, yet already subdivided into construction categories, as well as following a construction logic. For instance, instead of using pre-defined operations, such as the creation of a box or a cylinder, the user should define intermediate functions, e.g., 'slab' and 'column' which then invoke the pre-defined operations.

Although the CAD tool may not actually benefit from this organization of the program, it not only helps the user organize the modeling tasks, but also eases the translation to BIM, as it compels him to think in constructive terms from the start. Furthermore, when using intermediate abstractions that correspond to BIM pre-defined operations, such as a slab, column, or wall, the transition to BIM may be as simple as deleting the CAD operation invocation inside the function and rearranging the parameters to fit the BIM primitive.

## Evaluation

To evaluate our approach and exemplify some of the steps, we selected two case studies: the Wadala Tower in Mumbai from James Law Cybertecture, and the Astana National Library from BIG architects. Both projects present rather complex shapes that categorize them as buildings that clearly benefit from an algorithmic-based approach.

The following sections present an extended description of the steps followed to algorithmically model the constructive elements, such as slabs, beams, columns, walls and doors, in a CAD environment, and their consequent translation to BIM. We compare the modeling process used for either paradigm, their advantages, and their disadvantages regarding one another. Figure 1 shows the 3D models of the two mentioned case studies, generated in CAD and BIM applications.

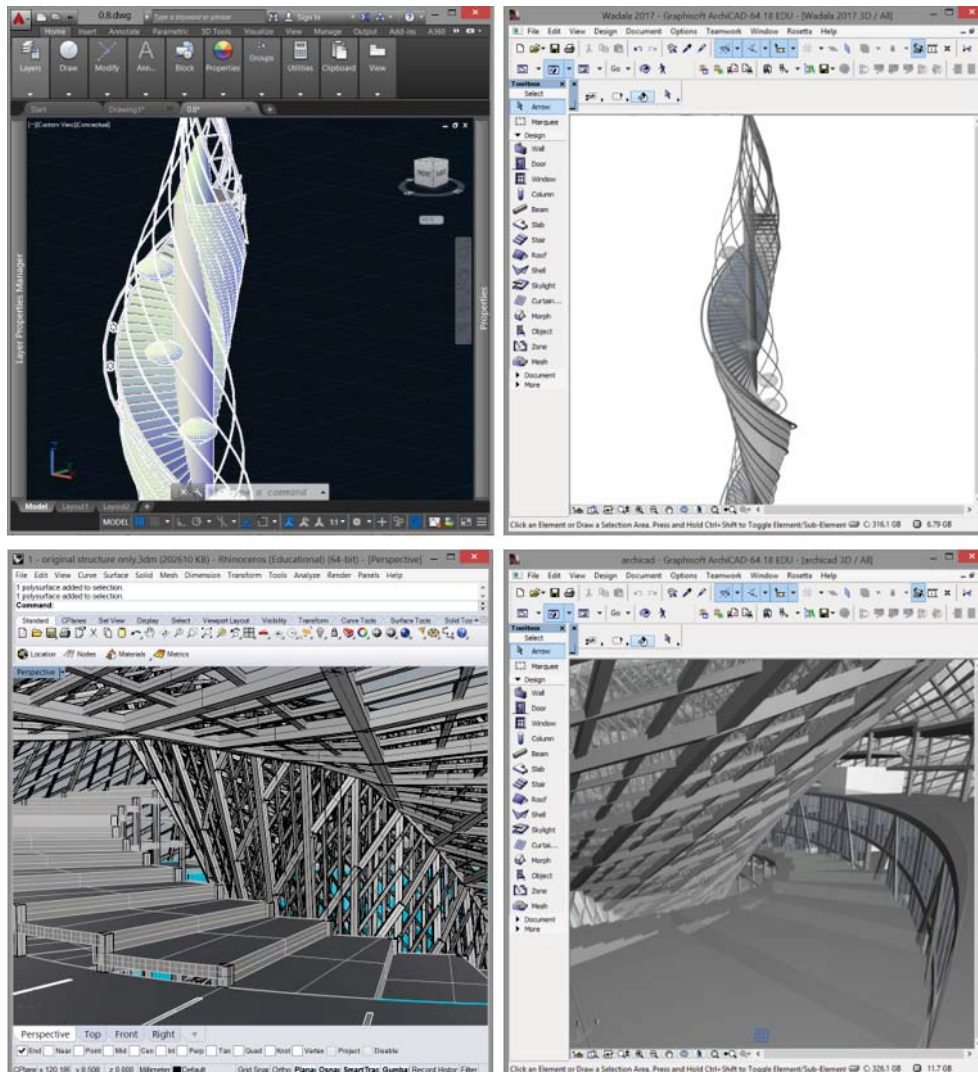

Figure 1. Wadala's 3D model generated in AutoCAD and ArchiCAD (on top) and Astana's 3D model generated in Rhinoceros and ArchiCAD (on the bottom)

## **Modeling tool**

The case studies were implemented in Rosetta, a portable generative design tool capable of generating parametric models in both CAD and BIM tools (Feist, et al., 2016). Rosetta's abstraction layer contains the common functionalities amongst CAD tools, such as procedures to create geometric shapes, like circles and boxes, and procedures that apply geometric transformations, including lofts, extrusions and sweeps (Leitão & Lopes, 2011).

Rosetta also includes operations for modeling the parts of a BIM model, such as slabs, walls, columns, and beams, among others. These operations are common to the two currently integrated BIM tools, meaning that from the same algorithmic description, Rosetta is able to produce similar models in both tools. Nevertheless, many operations are only available in specific tools, and with this in mind, Rosetta also provides the possibility to work with specific functionalities of each tool. For this purpose, however, the user must relinquish the portability of his programs.

## **Slabs**

The most common way of modeling a slab in a CAD paradigm would be to define its contour through a sequence of either lines or curves, create a surface from that contour and extrude it. In a BIM paradigm, the same contour can be used, but the last steps are unnecessary. The slab operation already entails the creation of a geometric element with a certain thickness, hence the user must only provide the contour. The thickness can be defined by the user or it can be left as the default definitions of the chosen family dictate.

A problem arises when Boolean operations are used to create the slabs in CAD. For the Wadala tower, the half-circle-shaped slabs were originally modeled through the subtraction of a parallelepiped to a cylinder. Converting them to the BIM paradigm required us to change the way we were conceiving them. We had to rethink the slab's shape and define its contour as a sequence of a line and an arc, which could be recognized by the BIM operation.

A similar issue was found in Astana's case, where the center slabs had a ring-shape. These were modeled subtracting a center cylinder to a group of broader ones. For BIM we had to implement a function capable of creating holes in a slab, but not via subtractions like in CAD. Instead, the function should receive two sequences of curves, one for the slab contour and another for the slab hole. In the BIM paradigm, the subtraction is implicit in the creation of an opening, since an opening in a slab is, by definition, a void.

## **Columns and Beams**

Modeling vertical columns in a CAD environment follows a similar logic to the slabs: an extrusion of the columns' profile. If the columns are not vertical, however, the process would be closer to the one we might also use for beams: a loft between two sections positioned in space, a sweep of the section along a line virtually drawn between the column's or the beam's start and end point, or an extrusion as well, only using a vector as input instead of a single measure.

In a BIM paradigm, none of these operations are available in order to restrict the creation of columns and beams to what is buildable. Therefore, we must rethink our approach and adapt it to BIM functions.

The column function in a BIM program usually requires a base point, the specification of the level at which it is created and the level immediately above (assuming the column covers only one floor) and an angle at which the columns is inclined. The beam function requires only two spatial locations, however the geometry created by both functions is not the same. Columns have flat bases, always parallel to the ground floor, whereas the beam section remains perpendicular to its axis. Either function benefit from the set of profiles offered in the programs' libraries and family, most of which also have changeable parameters for the element's section.

Whereas in CAD there was little distinction between columns and beams, in BIM there is a considerable difference. In Astana's case, the cross-beams of the ring-volume were, in fact, modeled using columns as it only made sense for them to be sectioned by their top and bottom slabs, like they would be if they were constructed.

## Walls

Modeling walls in CAD, much like slabs and vertical columns, usually requires the extrusion of the wall's base profile. An alternative approach, using a sweep of the wall's vertical profile along the wall's base line, might be preferred if the wall's position is not parallel to any of the axis.

In BIM applications, the wall function is available, waiting to receive two locations correspondent to the beginning and end of the wall, the level at which it is created and the level above. The wall profile can, naturally, be selected from the available families or libraries. This would seem like a smoother transition than the ones described before, yet our case studies presented quite some challenges.

The walls of Astana Library are arrayed in a circular path (see Figure 2). We created a function to distribute the two wall sets along the frame's spacing and the four floors. In our CAD approach, they were built from vertically swept rectangles (intended to be the wall profile) along virtual lines created in plan from the beginning to the end location of each wall. For a BIM application, we had no need to model the wall profile, as we did for CAD, since the program assumes the family values by default, such as thickness and material. Hence, the program was significantly simplified.

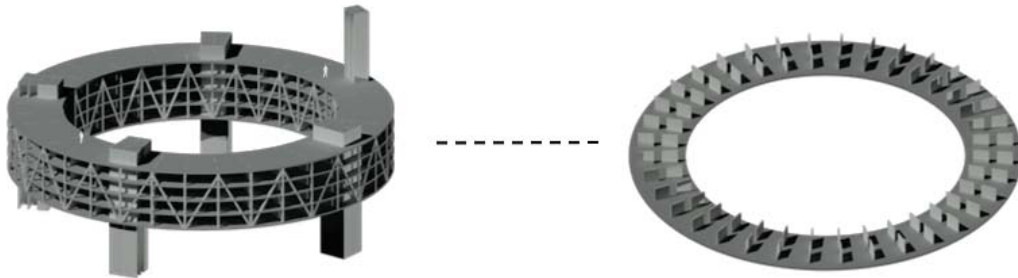

Figure 2. Astana's interior central volume (on the left) and a detail of the wall placement on one of the floor (on the right)

## Glass Walls

Other commonly modeled elements are glass walls, that in a CAD paradigm do not differ much from a normal wall, except with a smaller thickness to represent the glass perhaps. If the user so wishes, he may also model the metal framings that hold together the glass panels. However, in a BIM paradigm, he may take advantage of the pre-modeled elements, which already present all this detail and with changeable parameters. The curtain wall command allows the creation of sequences of rectangular glass panels framed by metal mullions and transoms. For different BIM applications, the same element might require a different order of the parameters, but generally speaking, to model a curtain wall one would need to supply the guiding points of the wall, the number of panels in the grid and their respective lengths, and, optionally, the sizes for the framings.

Modeling Wadala tower, we had to introduce a glass wall on the edge of every half-circle slab. For CAD applications, these were made via the extrusion of polygonal surfaces perpendicular to the slabs (Figure 3. left). Transitioning to BIM, however, we could take advantage of the pre-modeled elements, namely the curtain wall, in this case, automatically instilling more detail in the



model that we did not have to model ourselves (Figure 3. right). The exact same process occurred in the glass wall of Astana National Library.

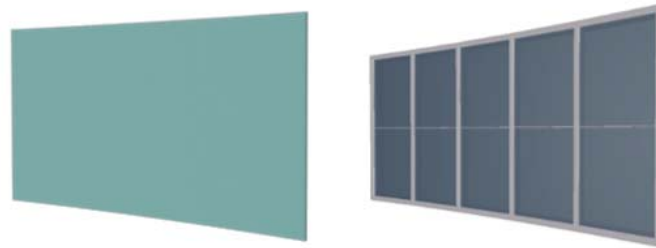

Figure 3. Glass Wall surface in CAD (on the left) and Curtain Wall object in BIM (on the right)

### Doors

Delving in to more detail, we come to doors. In a CAD environment, in an initial modeling phase, one might model a door as a hole on the wall. On a more advanced stage, the user might want to give it some more detail. However, the more detail we want, the more work we need to put into the modeling task.

Shifting to the BIM paradigm, we find several pre-modeled door types, so there is no need to model them. Moreover, if further ahead we had wished to change the door type, in BIM we only need to specify the type, whereas in CAD we would have to model a new design from scratch. Figure 4 presents three examples of door types changed with little effort in the BIM model. Furthermore, the insertion of a door in a wall does not require the creation of the hole in the wall, as it did in CAD. That process is implicit in BIM, although some limitations are imposed, for instance, as we may not create a door without a wall to host it. This mandatory modeling order sequence does not exist in CADs, where the user is allowed to model doors wherever he so desires, with no precedencies needed.



Figure 4. Astana's cores with three possible door types

### Building's skin

The modeling elements that usually present the biggest difficulties in the CAD-BIM transition are the ones we design without real consciousness of what structural elements they might represent. In such cases, the true challenge is the rethought of the design elements as construction elements. Our chosen case studies brought up some interesting situations, particularly regarding the buildings' skin.



The skin bars of Wadala Tower were modeled in CAD using sweeps: circular sections with the bars' radiuses would be dragged along path-curves, which twisted around the building core as they rose along the building height. Transitioning to the BIM paradigm, we had to convey structural meaning to these bars, and the solution we envisioned was to convert them into columns. Instead of path-curves, we used lists of points calculated at each floor height to generate a set of columns at each floor in replacement of the sweeps. However, the column function in the BIM paradigm required, not two points like in CAD, but the base-location and an angle to successfully incline the column. Hence, we implemented a column function of our own that, given two spatial locations, calculates the angle between them, along with the base point and the level heights. Figure 5 shows the façade skin with a set of columns highlighted in white.



Figure 5. Highlighted columns (in white) from Wadala's façade skin

In Astana's case, sweeps were also being used to generate the façade's structure. Only, instead of a circular section, a quadrangular one was dragged along multiple rectangles. In this case, we believed beam objects would be more appropriate as these elements had no apparent relation to the existing floor organization. We used the matrix of points already calculated during the CAD approach to generate the beams as well.

However, a problem arose in a specific BIM application: ArchiCAD, in defense of the constructive logic, does not allow the production of vertical beams nor horizontal columns. This presented an obstacle to our approach: as the façade completed a whole loop in its twisting movement, some of the structural elements assumed vertical positions. To surpass this issue, we implemented a function capable of determining if the given two locations for the creation of one beam aligned vertically. If they did, a column would be created instead of a beam.

## Façade Glass

A more challenging case is presented by curved façades covered in glass panels. These panels commonly have triangular shapes, to allow the grid to adjust to the façade. In a CAD environment, they are easily represented by triangular surfaces placed in space, possibly extruded to glass thickness. The user may also model the glass framing using lofts or sweeps, if he so wishes.

However, in the BIM paradigm there is no specific category of objects containing these elements, and the only elements that allow anything close to freeform modeling are morphs or masses. These elements, however, will not grant the object the desired semantics. Belonging to a glass or curtain wall category, for instance, would be a more appropriate semantic for a façade panel. To this end, the user would have to model new families adequate for the project.

Due to the triangulated grids of glass panels forming their façades, both case studies suffered from this problem. For CAD, they were modeled as triangular surfaces, while for BIM we began using morph panels with glass for material (see Figure 6). The projects are still in development, as is the chosen tool to model them, Rosetta. In the future, the tool is planned to allow the modeling of project specific elements, when no object provided by the BIM library fits the design purpose.

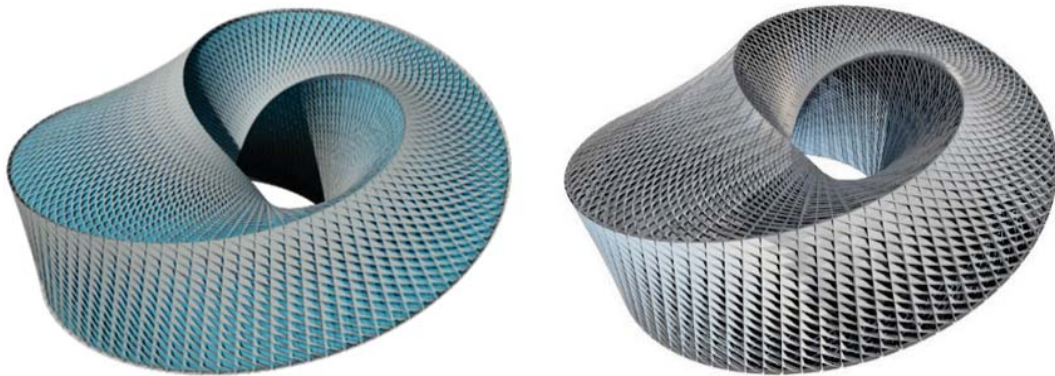

Figure 6. Astana's final model in CAD (on the left) and in BIM (on the right)

## Conclusion

In this paper we presented a methodology for CAD-BIM transition in the context of Algorithmic Design. We compared the two paradigms and the advantages and drawbacks each presents to the design process of an architectural creation. We exemplified the application of our methodology with two case studies we have modeled in a portable generative design tool, and that have undergone this translation process. We thoroughly explained both modeling phases, CAD and BIM, and the changes the program suffered in order to be ported to the second paradigm. We proposed a modeling sequence suitable to the BIM paradigm and we addressed some interdependencies that characterize the BIM logic for object creation.

During the translation process we verified a general simplification of the algorithmic description of the design. Shifting to the BIM paradigm, most geometry is implemented in the program through intermediate abstractions (such as slabs, columns, beams, etc.), since the user can benefit from pre-modeled objects' descriptions. The translation process also presented some limitations, however, as the CAD paradigm allows for higher levels of modeling freedom, when compared to BIM. As such, sometimes the user must envision more complicated solutions in order to convert his geometry into BIM elements.



Finally, we concluded that the ability to create new families is of crucial importance to the architect. The use of pre-modeled elements should be an advantage to the modeling process, but never a limitation to creativity. Furthermore, the architect should not have to feel compelled to change the design only to adapt to the existing objects. Hence, the possibility of altering or even creating our own families is essential to the full and correct use of the BIM paradigm. So far, Rosetta has missed to include this feature due to the significant differences between the different BIM tools, but future developments will focus on making this possible.

## Acknowledgments

This work was supported by national funds through Fundação para a Ciência e a Tecnologia (FCT) with reference UID/CEC/50021/2013.

## References

- Burry, M. (2011) *Scripting Cultures*, United Kingdom: John Wiley & Sons Ltd.
- Eastman, C., Teicholz, P., Sacks, R. and Liston, K. (2008) *BIM Handbook: A Guide to building Information Modeling for Owners, Managers, Designers, Engineers, and Contractors*, Hoboken, New Jersey: John Wiley & Sons, Inc.
- Feist, S., Barreto, G., Ferreira, B. and Leitão, A. (2016) 'Portable Generative Design for Building Information Modelling', *Living Systems and Micro-Utopias: Towards Continuous Designing*, Proceedings of the 21st International Conference of the Association for Computer-Aided Architectural Design Research in Asia CAADRIA 2016, Hong Kong, 147–156.
- Kalay, Y. (2004) *Architecture's New Media: Principles, Theories and Methods of Computer-Aided Design*, Massachusetts: The MIT Press.
- Kensek, K. and Noble, D. (2014) *Building Information Modeling: BIM in Current and Future Practice*, Hoboken, New Jersey and Canada: John Wiley & Sons, Inc.
- Leitão, A. and Lopes, J. (2011) 'Portable Generative Design for CAD Applications', *ACADIA 2011: Integration through Computation: Proceedings of the 31st annual conference of the Association for Computer Aided Design in Architecture (ACADIA)*, Banff, 196-203.
- Meredith, M. (2008) 'Never Enough (transform, repeat ad nauseam)', in Sakamoto, T. and Ferré, A. (ed.) *From control to design : parametric/algorithmic architecture*, Barcelona, New York: Actar-D.
- Shepherd, P., Hudson, R. and Hines, D. (2011) 'Aviva Stadium: A parametric success', *International Journal of Architectural Computing*, vol. 09, no. 02, pp. 167-185.
- Terzidis, K. (2006) *Algorithmic Architecture*, Abingdon and New York: Routledge, Taylor & Francis Group.
- Zboinska, M. (2015) 'Hybrid CAD/E platform supporting exploratory architectural design', *Computer-Aided Design*, no. 59, pp. 64–84.



# A chemical paradigm: Matter behavior as heterarchical organizations to generate a design method for resilient city patch

Orkun Beydađı<sup>1</sup>

<sup>1</sup>*Istanbul Technical University, studio Per Se, Istanbul*

<sup>1</sup>*obeydagi@gmail.com*

**Abstract.** Cities can be considered as complex information systems. They are adaptable, ever changing entities, which cannot be grasped through basic assumptions of how modernism used to do to plan cities. It processes its own information in an heterarchic way that defines patterns in an emergent behavior. Water, in this sense is a very crucial natural entity in the life of cities. However, it is commonly deleterious from the constructed environment, killing the ecologies it creates. Today, most of these water lands are diminished in size, either squeezed into canals or drained to open up space for streets. This can be defined as a wicked problem, since water as a natural entity always tend to find its own way sometimes by damaging the urban environment. Crucial point is to create the ecology with urban and natural environments again as a mutual understanding for a resilient city. This paper aims to search for how the ecological relationships of water in urban environment be reconsidered via computational simulation methods, while keeping its natural structure by adapting itself and manipulating the urban environment.

**Keywords.** *Emergence; Material Interactions; Natural Systems; Generative Systems; Ecology.*

## Information Junk

The perception of 'information' is being shifted through a fuzzier state past this century. It is shifted from a state of constant facts, to an unknown field where the reality is not a single entity but more of a changing boundary. This perception shift, bases itself to recent developments in quantum physics, as well as its sub effects to technology and later on to the societies. Information, no longer, can be stored in printed encyclopedias, but it turned into data systems adopting themselves every changing minute. This, however brings a taxonomy and archival problem, since we still tend to classify information like static entities. Wikipedia is an online contributed encyclopedia, but still classifies the information like the past century, underestimating a million other relationships every information is getting tied in every second. The 'fact' is now bended to multiple other new 'facts' by the help of its almost possible relationships. Every person, and every materiality has a power to generate and contribute new information that creates new relationships, boundaries together that bends the so-called 'fact' to new and changeable 'facts'. Mentioned by Kwinter, the unpredictable and fast nature of the archive system (internet), can place the scientific action and political method for everyone with a phone line and a hard drive, of which refined and disciplined eras and methods could not (2011). Our century old systems, still reacts to an information taxonomy based on facts, but not a network of possible facts, which in return creates unsustainable reactions in societies, politics, culture, and materiality. Politics is the most recent phenomenon with the rising authoritarianism, resulting from creating alternative so-called facts, and gaining power in a timeworn system, which responds to static realities.



## Heterarchies

However, this paper aims to focus more on to the materiality and its potential for suggesting a system of alternative facts, which transforms the information taxonomy and archival organizations, in order to develop new design methods for the urban environment.

Rather than hierarchies, network culture of today's societies require heterarchical organizational systems in their physical environments, in order to adopt with ever changing situations. In an interview with John Szot, Lebbeus Woods mentioned that the buildings today are still designed by 'background' and 'foreground' models called by Paul Rudolph, as a hierarchical model that set throughout the human history. A centralized 'jewel' of Cathedral in the past, or a starchitect monument, against the dark dense texture of city are both the same entities. However, the need is a new model that give form to the democratic society from old autocratic, oligarchic system, which also needs to be re-invented with the coming age of technology revolution (2012).

Heterarchical systems, in their nature, are not developable top-down organizational principles, but rather bottom-up emergences. Therefore, the main aim of this paper is about documenting possible interaction methods between matters and their changing organizational principles, from a geometric perspective, in order to understand the possible meta patterns it will generate for new classification systems that can be used to develop design methods for urban environments.

As a case study to implement the method, Istanbul, Kagithane river area is selected. Historically a rich region in terms of water ecology is drastically transformed into industrial and residential zone, therefore constitutes a problematic relationship with its natural environment. The key steps for the study are documenting matter reactions, specifically water and its various states, extracting pattern/network information and finally implementing the knowledge into the problematic zone.

## Human – Nature Relationship

First and foremost, the most crucial aspect to grasp the interactions of matters is to understand the geometric principles and nature relationships. Nature inspired design is under scope of architecture since the ancient ages. The geometric ratios, plan organizations, section – plan relationship, façade systems that extracted from natural forms lean to resemble the 'perfect' principles of nature. From the ancient Greek architecture to Le Corbusier's 'Modulor System' algebra information is extracted from the natural ratios and implemented in design information. Besides this, as a different approach, understanding nature evolved from extracting algebra information to mimicking and getting inspired by the nature for the general atmosphere of the architectural entity. Especially in baroque and rococo eras, architectural design principles are shifted towards a general atmospheric setup, rather than a completion of different architectural and structural components. This era mimics nature, not in terms of geometric principles, but as setting up the general atmosphere in order to react with the emotions.

Based on the first approach mentioned above, extracting the rational algebra information, is transformed with scientific developments through the last century. After Newton's 'Principia', with the help of Bohr's atom model to Einstein's general relativity theory to standard model; basic sciences shifted the perception of nature and allowed to reimagine it through complex information systems. This helped human beings to develop methods with a mutual ecological understanding between nature and built environments. As an example, growth of cities is better understood in terms of its relationships with economy, transport, social, warfare, etc. and new non-linear methods of city planning are developed with the help of complex nature understanding.





## Emergence and Material Interactions

The term 'emergence' in architectural discourse is most commonly conjure complexity, but without associated concepts, or mathematical mechanisms. In its common definition, emergence is the properties of a system that cannot be reasoned from its constituents, something more than sum of its parts. This definition is sort of true, however very vague for the use in architectural discourse. In sciences, emergence refers to the form and behavior production by natural systems that have an irreducible complexity, and need mathematical approach to model the processes. Architects should outline a working concept of emergence, and use mathematics to make it useful to designers (Hensel, Menges, Weinstock, 2004). As being explained above, the key point for documenting the behavior of the matter is to extract the mathematical information of the matter interactions, water and its reactions in this study specifically. It will then be categorized under certain geometric definitions made in the Metapolis dictionary: Geometry defined under cloud form, rock form, empty form or fencing form. Cloud form explains a suspension under interior or exterior forces with a fluid state; rock form defines a fixed transformation happened per se; void form shows a geometry as neither a figure, nor ground; fencing form on the other hand, formed by the movement of its own structure (Soriano, 2003).

Morphogenetic processes are complex enough that doesn't allow to recreate itself without a certain abstraction. The claim of reverse engineering natural behavior into its every tiny bit and redeveloping, brings another synthetic situation. In this context, the importance of the experimentation becomes vital. It seems like helping to resolve the natural behavior, but at the same time, experimentation recreates nature in other meanings. Iain Hamilton Grant, in an interview mentions about a paradigm shift from the physical to chemical. As he explains the main character of this shift, he refers to different modalities of analysis and synthesis. Physics, in order to detect the fact, mostly, uses analysis based on data, mathematics and observation. However, at the same time, chemistry mixes analysis with synthesis, which leads to recreate the nature, rather than detecting it. Therefore, "information, only emerges through production", or in another saying, one cannot understand nature without "recreating" it; and at the same time by recreating, nature can never be like as it is synthesized from. This dilemma not only questions our knowledge of nature and information, however leads to a new ecology that natural and synthetic are nested between each other (Kolatan, 2012). In order to grasp the nature through experimentation, with a shift to chemical paradigm, a new 'nature' can be emerged with analysis and synthesis together.

## Problem: Water in Urban Context

Socio-economic conditions of this era, transforms the usage of natural habitats, while as altering morphologies of urban zones. Uncontrolled, unplanned, scattered and low cost growth of cities, effect the nature around built environment, like agriculture and forest zones, water sheds, hydrological divide. (Bolen, 2009).

Water is one of the most vital matters in the whole known living systems. It is searched in the first place in an environment, in order to start investigating the life forms. Humans, animals, plants, all life forms exist, thanks to the presence of water. It makes up most mass of the animal body and takes up more than half of the Earth's surface.

However, water is deleterious in the daily urban life. Constructed urban areas, are mainly bases itself on man-made infrastructure, which lacks interaction with water as a material. Water, most likely has negative-unwanted effects on the infrastructure. Construction systems are designed to keep water away, to sustain its structure.

Such a vital matter, is deleterious from the most of the built environment, which underestimates the natural forces that makes up and sustains water in its ecological zone. Buildings are forced to keep water away, or use it in controlled parts. Infrastructural necessities are obliged to keep away





and use water in our daily lives. Pipes, drainage and sewage systems are crucial and obligatory for urban environment to keep the entire system away from the water, thus it is not getting damaged.

Besides, global warming is threatening our cities with the rising levels of sea. It has been said that cities like New York or Amsterdam are under threat of this rising sea levels, therefore necessary precautions have to be taken before water levels rise and threat the urban structures. However, thinking even broader, planet Earth had such dramatic changes too many times in its millions of years of lifetime. Planet Earth survived, planetary tectonics divisions, ice ages, even meteor crashes, which are in fact events in its lifecycle. The answer to survive from all catastrophes, should be to be in a constant adaptation, by grasping how systems and their ecologies work.

Water (or water systems) in urban context can be considered as 'wicked problem', which is a phrase originally used in social planning to describe a problem that is difficult or impossible to solve because of incomplete, contradictory, and changing requirements that are often difficult to recognize. This phrase also very commonly used for environmental problems, too. Water, as being described above as an emergent entity, has this relational problem with modern city design, which can be described as a wicked problem, and therefore needs a computational approach to understand its nature and possible new 'natures' created during experimentation.

Istanbul, located between two seas and fulfilled with an amazing number of water sheds is an important ecological land through the ages. From Byzantium to Ottoman and republic times, with the effect of technological improvements this water ecology has been changed in a way to control the water as it has been in a modern city design approach. Today, most of these water lands are diminished in size, either squeezed into canals or drained to create space for streets. However, water, as being a fluid, still finds its way from underground or occurs floods in time. This shows us that the modern city design approaches may not be the best way to deal with water in urban context. In today's Istanbul, it can be seen that rivers can be categorized into three systems based on the research by Hulya Dinc and Fulin Bolen (2004). It is either in its natural structure, open section-canal or closed section. In a quote by Spirn on Jane Jacobs she says: "Jacobs advocated an ecological approach to designing and managing cities, arguing that cities are problems of organized complexity, akin to living organisms, and that there are lessons for urban design from the study of systems where half-dozen or even several dozen quantities are all varying simultaneously and in subtly interconnected ways" (Jacobs 1961: 433, 2011).

## Method

At this point, it is important to discuss how design methodology can be blended together with the material taken as an active entity. In order to deal with this problem, first step is to grasp water's/fluid's behavior under different circumstances. And later it should be synthesized with the information that material brings under the designer's intent. The '(n)certainities' studios led by Francois Roche and Ezio Blasetti, participants will interact various materials together to create new formations and examine their outcomes. The used material emerges out from its own existence and expresses itself as a new entity. The emergent behavior is controlled by a natural systems code, which is designed to allow unexpected outcomes. These codes/simulations are at the same time created based on the data extracted from the experiments. Although, it seems it is opposing to the chemical paradigm explained above, for extracting mathematical information of nature, it actually is no different than repeating the experiment through analysis and synthesis in a computer environment. The code, besides extracting nature's data, analyses and synthesises matter in its own description. Roche explains this as: 'The constructive materiality of self-organizing entity is an agent of its constant recreation through the schizophrenic energy between its bio-degradable disappearance and the *continuation of its physicality* (Roche, 2010).



In this study, water, its multiple states and their numerous interaction will be examined. Main aim here is to create a design method, free from the experimentation methodology. Therefore, no systematic interaction method will be chosen as a sample, however focus will be more shifted on the problem area, Kagithane river region. Later on, it is needed to specify a simulation to test how this behavior can react with its context to create a mutual condition with the water ecology and urban area. This exercise exemplifies an adaptive dynamic pattern reacting to multiple scales, which creates an ecology between its interior and exterior forces.

The aim of this study is to look for possible new design methodologies based on matter interactions, and focuses on the emerging and heterarchic behavior of matters. Generating new natures, while trying to understand it, is one of the main quests following the chemical paradigm, through the process. Implementation of this methodology can be unconstrained by scales, however the urban problem of water systems is taken as a case study in the example of Istanbul Kagithane river, to exemplify a concentrated study over one region.

## Mapping Study

Istanbul, is laying in the center of one of the world's most vital ecological lands. Formed by the tectonic movements of the Northern Anatolian fault line, it stays in the center of the transition ecosystem from Black Sea to Mediterranean. Istanbul's ecologic environment is highly variant, in terms of its flora and fauna, which is supported by multiple water sources and their relations.

It can be detected from various imagery resources that Istanbul's hydrological divide preserves its natural structure from the Byzantium times until 1950s and have a high level of nature-urban relationship (Salman, Y., Kuban, D., 2006, Tekeli, İ., Akbayer, N. 1994, Yazır, R.S., 1984, Koçu, R.E., 1963). Starting from republic era, and especially after the year 1950, the importance given to roads following the increasing population, as well as Bosphorus bridges after 1970s transformed Istanbul's morphology and development direction rapidly. In parallel to this development process, city's watersheds, its land use relationship with the urban settlements and city's users is also started to transform (İBB, 2008) (Kuban, 2004).

Starting from the year 1950, industrial zoning over watersheds rapidly increased, with its changing transportation models and summoned migration. These processes effected natural structure of watersheds and have its physical structure lost through time. For example, the river Lycos, which was disembogued in Yenikapi, had been dried and converted to Vatan avenue, one of the major roads in the old city of Istanbul. (Levent E, 2009), Furthermore, rivers like Ortakoy, Bebek, İhlamur had been taken into closed system tight canals and now is using as pedestrian-vehicle road. Watersheds and hydrological divides, once had strong ties with urban environment, lost these ties because of the demand of built environments' concrete surface area (İBB, 2010).

In order to identify the problem clearly historic maps of Istanbul is examined. Focus has been given to late Ottoman and early republic era, before and after 1950s, when most of the nature destructive construction activities had happened. One map and three aerial imageries has been examined: 1909 Ottoman Map (based on envanter.gov.tr), 1946, 1960 and 1970 aerial images (based on istanbulurbandatabase.com).



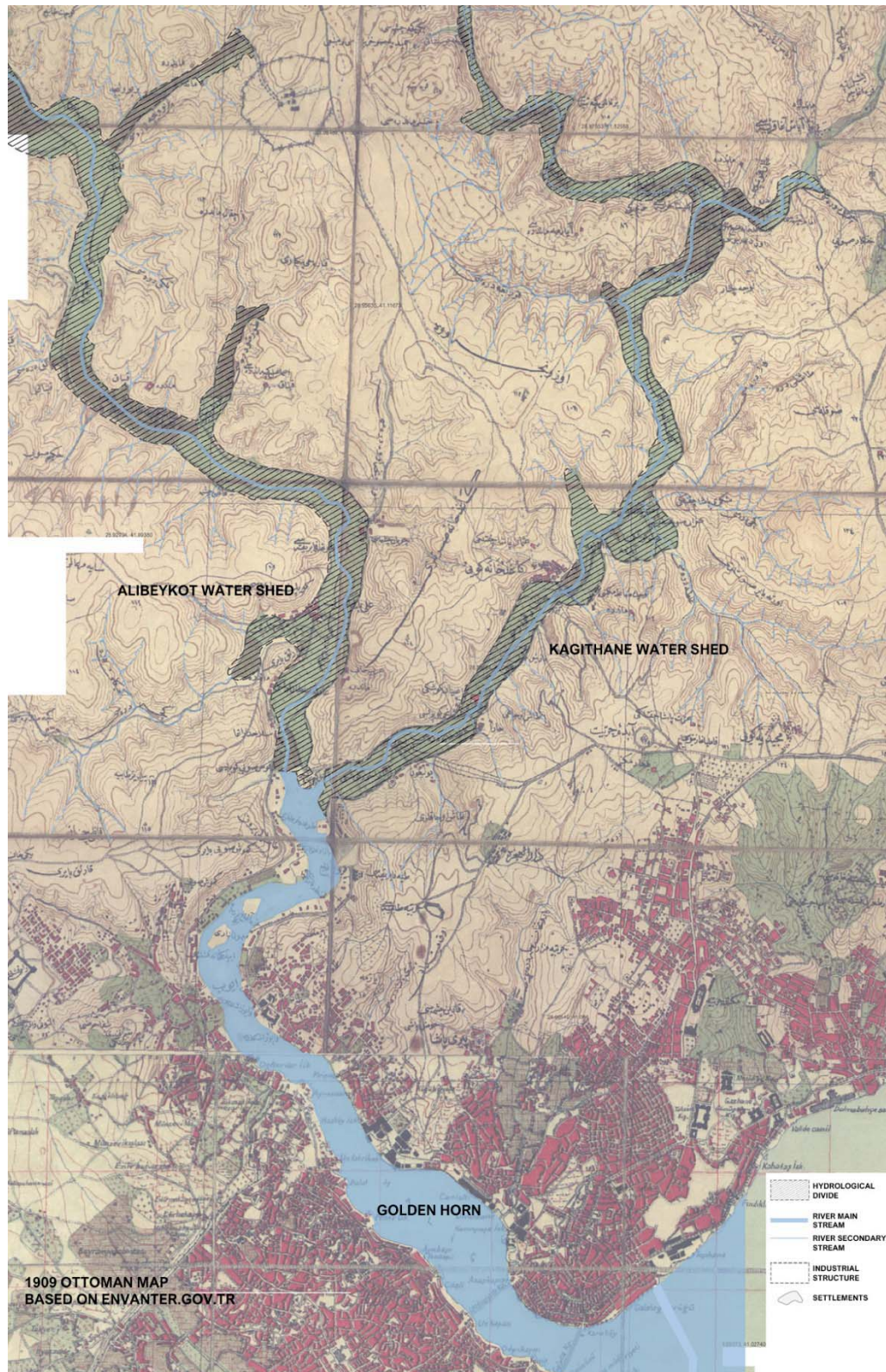

Figure 1. 1909 Ottoman Map

Kagithane river lays on the biggest watershed on Istanbul's European area. It lays on the southern golden horn hydrological divide and its approximate length is 86.196m (IBB, ISKI, 2008). Kagithane watershed, was since early times an attraction point. Sultans of Ottoman were interested in building palaces and gardens for recreation of both the Royal family and the public. Described by Resad Ekrem Kocu, in *Old Turkish Gardens* by Gonul Evyapan '... The river banks were divided into parcels, from Kagithane Village to the Karaagac Palacette at the end of the Golden Horn; and on each lot was built a beautiful palacette and a tulip garden, to be distributed on the wealthy of Istanbul. At Kagithane, besides Sultan's magnificent accomodations, were thus built 170 palacettes, each of a separate beauty, and each given a special name; and the totality of this large flourishing area was called Sad'abad...' (1999). Looking at the 1909 Ottoman map. It is clearly visible that the watershed is left in its natural structure, allowing space for the Sadabad gardens. At a later stage, in the 1946 aerial imageries, it can be visible that the watershed mostly keeps the same natural structure. Construction boom was not yet started, however Golden Horn part was planned as the industrial zone, therefore the area was vulnerable to lose its nature water structure.

On the other hand, after 1950s, when Turkey started an infrastructure and construction rally, especially in Istanbul. Since Golden Horn is planned as industrial zone, Kagithane watershed was started to fill with industrial areas. Water was a cheap resource to use and spill the wastes of the factories. Especially Alibeykoy river and over its bed, industrial zone constructions, led the structure of the hydrological divide lost its natural properties.

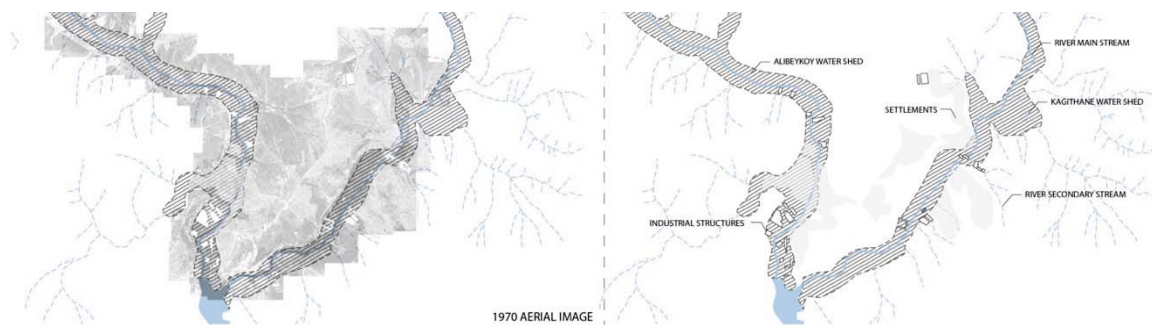

Figure 2. 1970 aerial image comparison

## Topography – Hydrological divide relationship // Upper Kagithane watershed

This paper aims to look for speculations over how an adaptive urban system can be managed that will have a mutual zone with its natural ecology, in terms of the hydrological systems. Kagithane region in Istanbul, especially this past century, is a problematic area with most of the industrial campuses located in the watershed zone. Main intention, is to generate patterns for a resilient city patch, which responds to natural structures and create a mutual ecology with the hydrological divide and urban environment.

In order to develop patterns for the urban patch, first step determined, is to experiment and understand the behavior of water. Water, as observable form, is a dynamic, ever changing entity. It fills its container with a surface tension and has the ability to adopt due to various external forces. Gravity, among all forces, is the highest effective force that shapes water, as well as wind or tectonic movements. Understanding the effects of these forces can be first detected through what different forms of abstraction water can get.



Fluid reaction is an animating system. It shows a process of reacting forces, which effects boundary changes. The method followed in this case, is capturing sequences of images from a water surface and recreating them to express the boundary changes under various force effects. Tracing images to reduce the clutter, expresses actual boundary lines in a still image as an abstraction. The sequential images help us to grasp under what forces the boundaries are changed and also documenting these forces as a separate layer. This helps to create a system that can generate new boundary conditions under the same force effects.

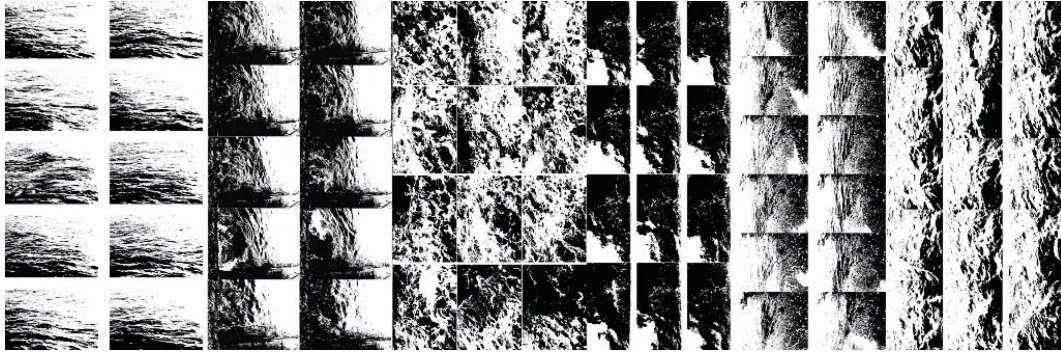

Figure 3. Sequential water drawings

These drawings create an outline for a broader simulation to detect water behavior under various other forces. In order to develop this system, first of all the slopes of the topography have been analyzed. In the upper Kagithane region, from Cendere St., Guzelbahce St. and main stream parts, sections had taken to observe slope of topography along with the existing and early (1909) built environment borders.



Figure 4. Kagithane watershed: problem area

### TOPOGRAPHY OF WATERSHED

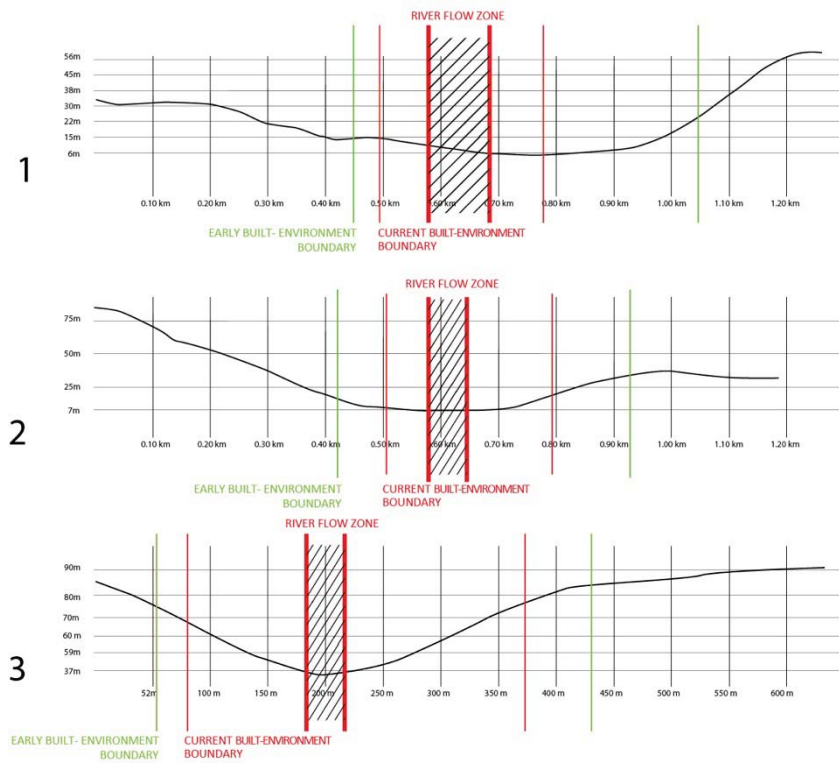

Figure 5. Settlements river bed relationship in sections

These two locations, as section 2 and 3 have taken, are where main stream of the river is dried and turned into streets. As visible in the graphics, settlements are started to penetrate into the watershed impact area and have a forceful geometric relationship with the topography.

On behalf of these information, in order to see water boundary propagation, a particle and fluid simulation is prepared. For this simulation, as a geometric definition, point method is being determined. This method is an agent based approach which is generative in the sense of opening new opportunities for multiple different geometries. It simulates the mass flow rate of water in its bed and possible propagation extends in relation with the topography. Starting from the main stream, this simulation method shows how water sprawls to secondary branches and how gravity and other forces effect the flow.

A crucial aspect to keep in mind is, this simulation method doesn't aim a true scientific flow simulation, but rather an abstracted geometric animation that mimics the real world forces. It is simply how a system can be created regardless of factual parameters. Therefore, it creates an abstracted geometric system defining relationships between water, topography and built environment.

As simulation ran, it generates particles emerging from a higher point of topography until sea level. Main force applied is the gravity that keeps particles in the riverbed, thanks to the collision method between the particles and the topography model. Moreover, in order to imitate water behavior, collision with the topography has not been kept too strict, but more shallow. By this way, water can penetrate inside the topography, however with a certain degree, which mimics earth's porous assembly. As visible in figure 6, particles define a region, covering the river and its bed.





A chemical paradigm: Matter behavior as heterarchical organizations to generate a design method for resilient city patch  
Orkun Beydagi

With the help of a script, particles in the outer boundary is selected to define curves, that will indicate the propagation extend of possible flow of the riverbed.



Figure 6. Particle simulation

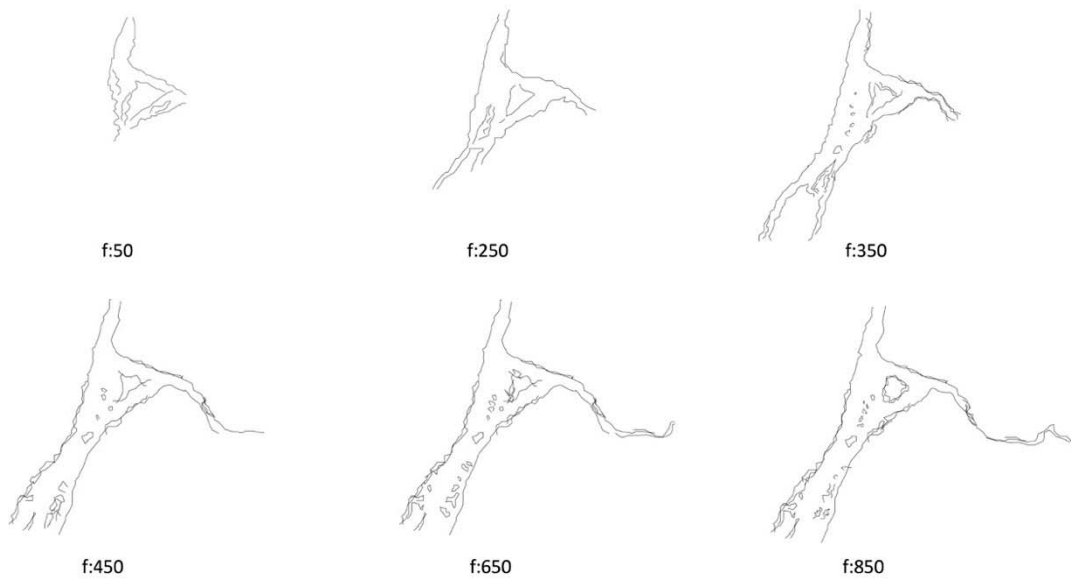
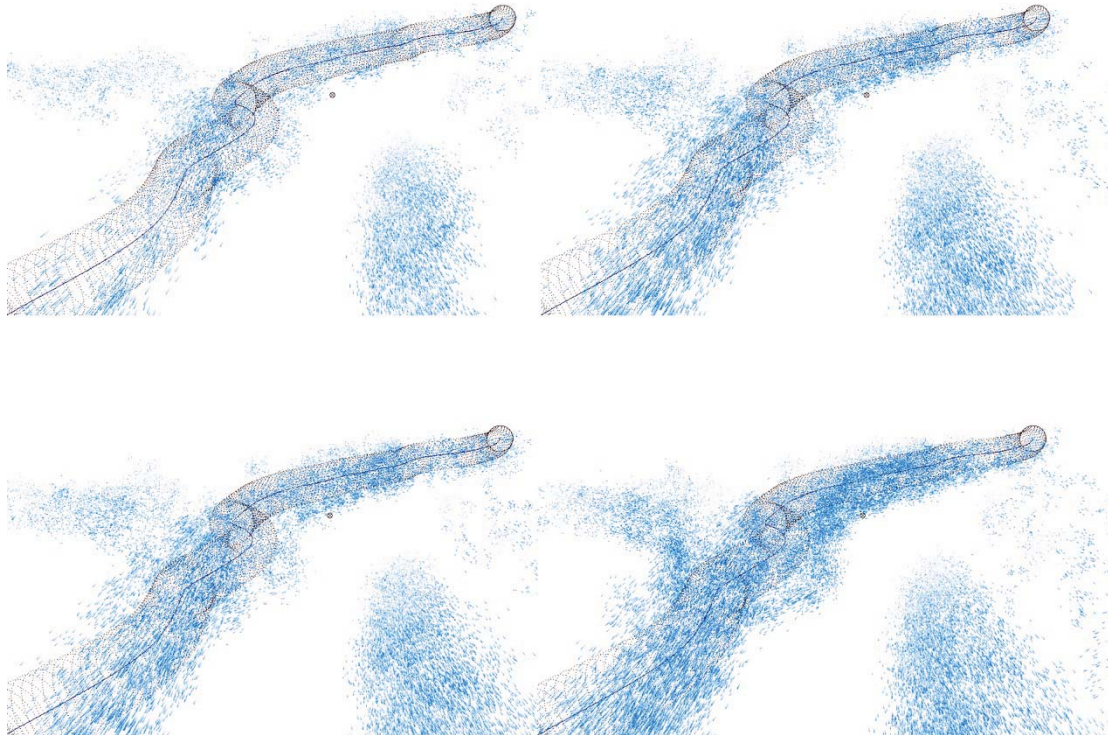

Figure 7. Particle simulation: timeframes



*Figure 8. Particle simulation: Threshold points perspective*

In a certain timeframe, simulation is interrupted to compare the increase of the water flow. Frames are set by the thresholds where increase have dramatically changed. River propagate extends are visibly changing through as simulation continues, which defines the minimum and maximum values the river flow can get. The same data is compared with the sections shown in the previous part, which makes the topography and flow relation visible.

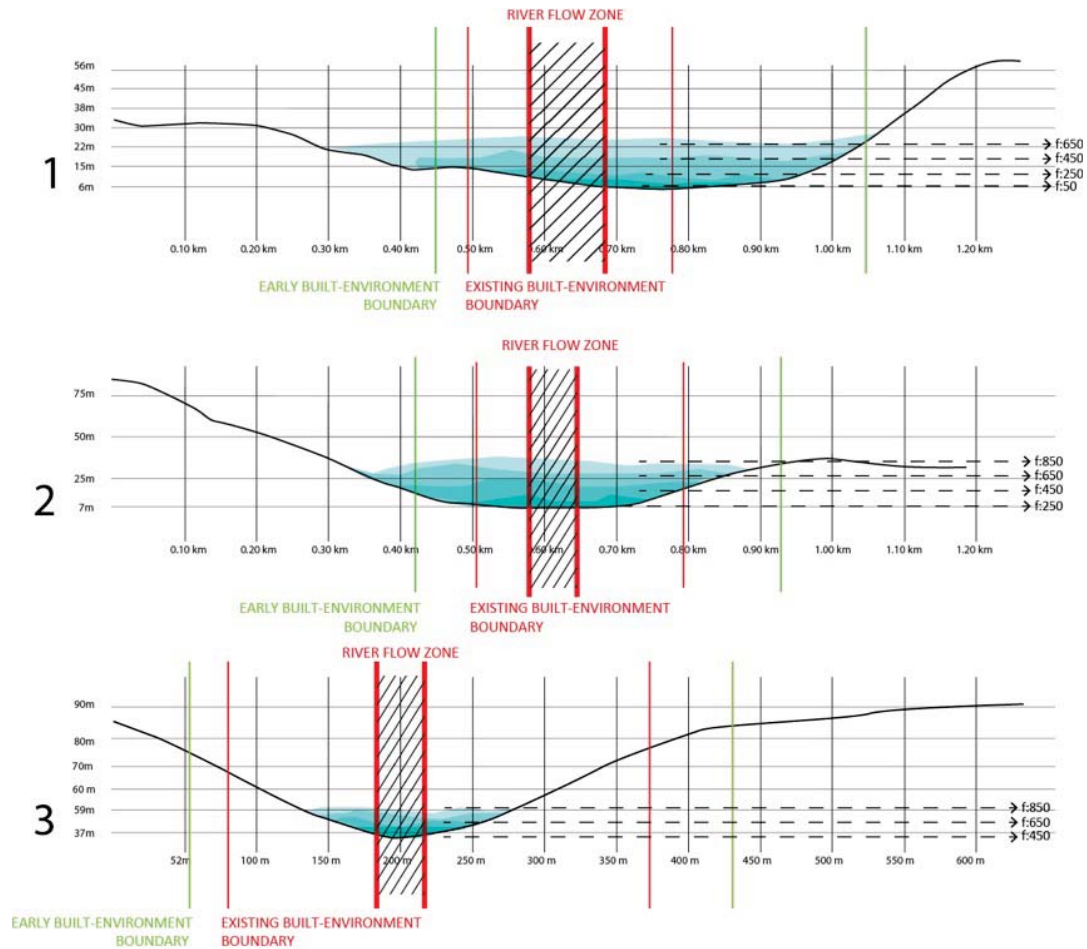

Figure 9. Kagithane watershed simulation result in sections

In a certain timeframe, simulation is interrupted to compare the increase of the water flow. Frames are set by the thresholds where increase have dramatically changed. River propagate extends are visibly changing through as simulation continues, which defines the minimum and maximum values the river flow can get. The same data is compared with the sections shown in the previous part, which makes the topography and flow relation visible.

## Proposal

The simulation technique above brings multiple patterns of points, geometrically adaptable to its container, in this case the river bed, and can be interpreted with various different geometric ways. This research focuses on the line drawings it will generate to see the propagate extend of the river flow on its bed. These multiple crumpled lines, brings various other boundary options for an adaptive and resilient patch. Unlike the modern construction techniques opposed throughout this paper, main aim is to recreate natural structural relationships, which will have a mutual understanding between the hydrological ecology and urban structures.

River bed, should be, in most cases, free from any infrastructural or structural entities. The generated crumpled lines are the basis of any form of planning or urban design to be made on the area. Since these lines indicate multiple levels of water can rise or decrease, it will help to

control the water flood upon unexpected climatic events. In fact, these areas are acting as buffer zones to keep water with its natural habitat, while as creating recreational areas for the urban user. Wetlands, rocks and rammed earth can define some of the zones designed for these buffer zones.

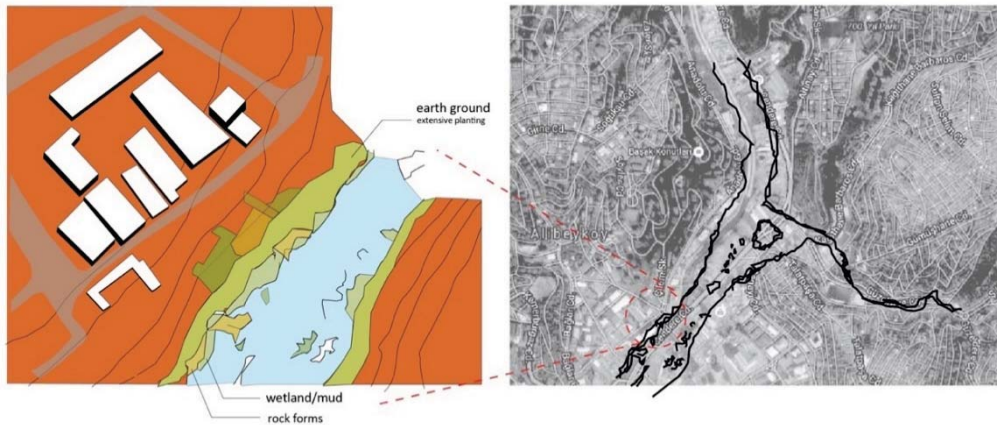

Figure 10. Possible proposal for a riverbed zone

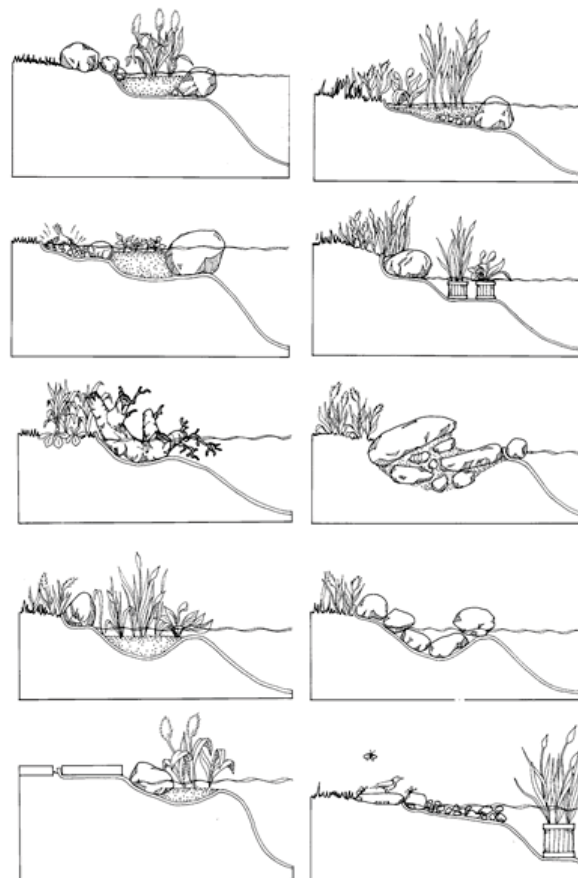

Figure 11. Natural river bed, possible section relationships





## References

- Kwinter, S., *Requiem for the City at the End of the Millennium*, pp. 68, Actar, New York, 2010.
- [1] John Szot: Interview with LW---'the ineffable' (2012, February 26). Retrieved January 14, 2016, from <https://lebbeuswoods.wordpress.com/2012/02/26/john-szot-interview-with-lw-the-ineffable/>
- Hensel, M., Menges, A., Weinstock, M. (eds.), *Emergence: Morphogenetic Design Strategies, Architectural Design*, vol. 74, no. 3, pp. 7, Wiley Academy, London, 2004.
- Soriano, F., *Geometry. The Metapolis Dictionary of Advanced Architecture: City, Technology and Society in the Information Age*, pp. 260, New York, Actar, 2003.
- Kolatan, F., *Of Mixing and Making*, in Ruel-Bergeron, S. (ed.), *Tarp Architecture Manual: Not Nature*, pp. 75, Pratt Institute GAUD, New York, 2012.
- Spirn, A., *Ecological Urbanism: A Framework for The Design Of Resilient Cities*, pp. 4, MIT Press, Cambridge, 2011.
- [2] Roche, F., *Scenari-(n)certainities*, <http://www.new-territories.com/blog/ncertainities/col12/>, 2012, 10.05.2013.
- Bölen, F., *İstanbul'da Yapılaşma Yoğunluğu Yaşanabilir Alan İlişkisi*, vol. 8, no:1, pp. 127- 137, İTÜ Dergisi, Mimarlık, Planlama ve Tasarım, İstanbul, 2009.
- İstanbul Büyükşehir Belediyesi. İBB, *Alt Yapı Mühendislik "İstanbul'un Asya, Avrupa Yakası Dereleri Raporu*, İstanbul, 2008.
- İstanbul Büyükşehir Belediyesi Park Bahçeler Müdürlüğü, İBB., [http:// www.ibb.gov.tr/tr-TR/BilgiHizmetleri/Istatistikler/Documents/bldhizmetleri/2010/parkvebahceler\\_mud\\_2004-%202010.pdf](http://www.ibb.gov.tr/tr-TR/BilgiHizmetleri/Istatistikler/Documents/bldhizmetleri/2010/parkvebahceler_mud_2004-%202010.pdf) (taken on, 05.03. 2014), 2010.
- Kuban,D., *İstanbul Bir Kent Tarihidir, Tarih Vakfı Yurt Yayınları*, İstanbul, 2004.
- Salman, Y., Kuban, D., *Boğaziçi Tarihi Sit Alanının Yok Oluş Süreci/The Physical Corruption of The Bosphorus Historic Site*, pp. 104-112 ,İTÜ Dergisi Seri A, Mimarlık Planlama ve Tasarım, 2006.
- Tekeli, İ., Akbayar, N., *Dünden bugüne İstanbul Ansiklopedisi, İstanbul Türkiye Ekonomik ve Toplumsal Tarih Vakfı Kültür Bakanlığı Yayınları*, İstanbul, 1994.
- Yazır, R.S., *Görsel Türkiye Ansiklopedisi, 2.Cilt, 4.Cilt, Görsel Yayınları*, İstanbul, Kutahya, 1984.
- Dinç, H. & Bölen, F., *The Physical Structure of Streams in Istanbul. Journal of Planning*, 24(2), pp.107–120. Available at: <https://dx.doi.org/10.5505/planlama.2014.97269>, 2004.
- Levent E., Eriş K., *Bayrampaşa (Lykos) Deresi Havzası ve Ağzındaki Yenikapı (Theodosius) Limanı Kıyı Alanındaki (Marmara Denizi) Değişim Süreçleri*, 62. Türkiye Jeoloji Kurultayı, MTA – Ankara, 2009.
- [3] [www.envanter.gov.tr](http://www.envanter.gov.tr).
- [4] [www.istanbulurbandatabase.com](http://www.istanbulurbandatabase.com).
- Evyapan, G.A., *Old Turkish Gardens: Old Istanbul Gardens in Particular*, METU Faculty of Architecture Press, Ankara, 1999.



## Origami Textures for Adaptive Plate and Shell Structures

Maurizio Giodice<sup>1</sup>, Francesco Romeo<sup>2</sup>

<sup>1</sup>*Sapienza University of Rome, Italy*

<sup>1</sup>*maurizio.giodice@uniroma1.it*, <sup>2</sup>*francesco.romeo@uniroma1.it*.

**Abstract.** The kinematic and static behavior of plate and shell structures based on origami patterns is investigated in view of their potential applications as adaptive surfaces in architecture. The broad, multi-disciplinary and rapidly evolving scientific contexts addressing origami design range from mathematics, physics, engineering and architecture. Restricting ourselves to architectural applications, we focus on the analysis of plate and shell structural solutions able to change their configurations in reaction to users' needs or environmental inputs. The structural and geometric potentialities of adaptive folded surfaces stem from their unique capability of combining efficient resisting mechanisms, due to their corrugation, in statically constrained configurations, with the ease of varying their global geometry, due to rigid body motions, throughout the folding phase. Thus, starting from planar states, depending on the underlying folding pattern design, folding surfaces may take a variety of prescribed form-resistant spatial configurations.

**Keywords.** *Adaptive Structures; Folded Surfaces; Origami Pattern; Miura-ori; Corrugated Structures.*

### Introduction

Several recent contemporary architectural researches aim at achieving evocative formal expression based on complex non-standard morphologies while optimizing functional performances. While the former aspect is usually developed by relying on digital form-finding tools, the latter takes advantage of the constant innovation of materials and technologies. In this context adaptive architecture, a multi-disciplinary field concerned with "dynamic" buildings, designed to adapt to demand, poses challenging design issues implying to conceive structural solutions actively contributing to the overall design integrated process.

The state of the art on structural adaptive surfaces shows that folding solutions, tessellated according to origami patterns, are suitable and effective in obtaining robust mechanisms with variable geometries (Schenk, 2011, Filipov, 2015). Starting from a planar state, folding surfaces allow to achieve various spatial configurations depending on the prescribed folding pattern defined during the design phase. These configurations have led to investigate possible scenarios that can be obtained by exploiting folds aesthetic and mechanical properties. In essence, the ultimate goal of this study is to define efficient structural systems, combining the corrugation form resistant capability with the possibility of formal metamorphosis of the folded process. The investigation is managed through a combined approach in which analytic, numerical, experimental and heuristic aspects are taken into account.

Aiming to design mobile flat and curved structural systems, a systematic investigation of adaptive surfaces, generated according to parametric laws, shows that origami patterns provide a wide spectrum of geometrical possibilities enabling to exploit both, bidirectional corrugation in a static configuration and deployability. The latter entails a kinematics involving few degrees of freedom (d.o.f.), defined by the N-3 relationship, where N represents the number of folds converging to a vertex. In this realm, we consider "rigid-origami", systems in which large global deformations are achieved only as a result of the opening and closing of the folds (Tachi, 2010).

In particular, the Miura-ori pattern, including spatially modulated (generalized) patterns and thick panels, is the chosen tessellation [3].

Recently, origami patterns have attracted great attention in various scientific contexts. Origami, three-dimensional surfaces created from a process of folding two-dimensional sheets along creases, provides an interesting source for inter-disciplinary designers. Mathematicians, scientists, and engineers have exploited the folded objects' deformability and compactness in diverse applications, ranging from mechanical metamaterials (e.g., metamaterials with a negative Poisson's ratio, Cheng, 2014), to biomedical appliance (e.g., heart stents, Kuribayashi, 2006), aerospace equipments (e.g., foldable telescope lens, Gardner, 2006), automotive safety (e.g., guard arils and airbags, Cromvik, 2006), and design (e.g., furniture, bags, You, 2011).

Restricting ourselves to architectural applications, we focus on the analysis of plate and shell structural solutions able to change their configurations in reaction to users' needs or environmental inputs. In the theoretical analysis proposed in this study two limit assumptions are considered for the fold modeling. Ideal cylindrical hinges are considered throughout the kinematic analysis while continuous origami configurations are used in the static analysis. In the experimental study, the actual fold elastic properties are identified by means of static tests and a finite element model updating approach.

The paper is organized as follows: at first the origami pattern geometric construction is presented, afterwards the mechanical performance is addressed by distinguishing between the kinematic and static behavior. The theoretical investigations are then validated through an experimental campaign whose initial results are eventually reported.

## Origami geometric description

The geometric construction phase is carried out by implementing the origami pattern geometric features through the definition of digital visual algorithms. More specifically, the basic geometries of the Miura-ori pattern are generated according to a parametric-geometrical method, both in the classical form, suitable for planar configurations and, in the generalized version, for approximated barrel vault.

### Miura-ori pattern

Miura-ori patterns, named after its inventor, the Japanese astrophysicist Koryo Miura (1985, 1997), are periodic rigid structures consisting of a variable number of base cells, each made of 4 parallelograms, whose d.o.f. are defined by the N-3 relationship, where N represents the number of folds converging to a vertex (see Figure 1). Geometrically, the Miura-ori pattern evolves according to a "herringbone" design, resulting from the serial union of convex (mountain) and concave (valleys) creases.

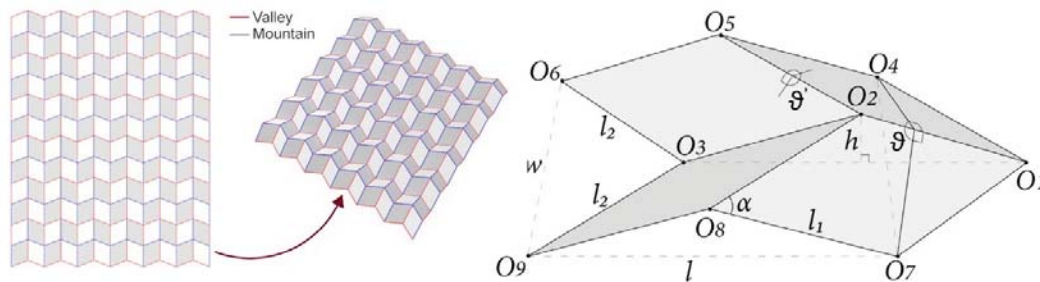

Figure 1. Miura-ori pattern with mountain and valley folds, Miura-ori base cell.

More specifically, this pattern is described by rigid components: two fold lengths and a planar angle. The dihedral angle  $\vartheta$  between two contiguous faces, is the parameter involved in determining the bending of the Miura-ori.

The suitability of Miura-ori in folding structures applications has to be found in its geometric properties, namely (Tachi, 2010):

- high degree of symmetry, represented by the periodicity in both planar directions;
- in the plane it has only one isometric degree of freedom, the dihedral angle of each single fold;
- in the plane, if subjected to in-plane stresses, a negative Poisson ratio is obtained, so during the bending phase, the overall size of the Miura-ori decreases in both directions;
- in the space, if subjected to bending stresses, a positive Poisson ratio is obtained, opposite in the sign but equal in value to the previous one;
- it is a rigid-foldable pattern, so it can be isometrically folded starting from a flat configuration to a fully folded configuration, throughout a completely rigid process;
- it is a flat-foldable tessellation, therefore, in the totally folded configuration, all the facets of the model are coplanar.

A Miura-ori tessellation made of unit cells, not necessarily identical, but made by varying the shape across the tessellation, is called "generalized Miura-ori" pattern. With this kind of tessellation, a Miura-ori pattern is obtained capable to approximate an arbitrary surface with intrinsic curvature, preserving the rigid-foldability and flat-foldability properties, as shown in Figure 2.

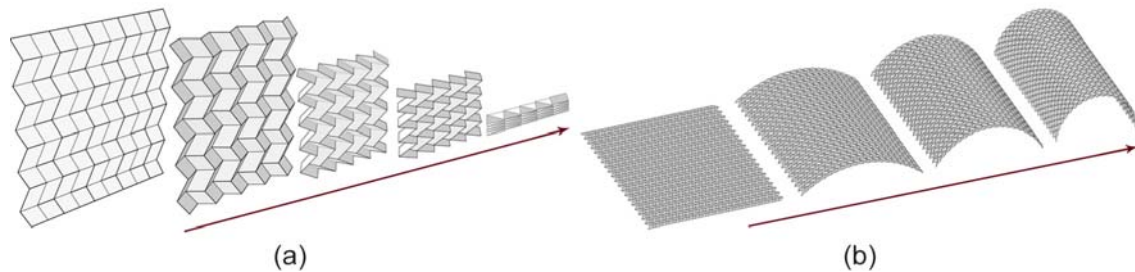

Figure 2. Miura-ori pattern folding motion: (a) Planar configuration, (b) Generalized configuration.

### **Morphogenesis: a parametric-geometrical method**

The geometrical method consists in defining the geometric relationships between different portions of the model. These relationships can occur both through the movement of nodes and through the translational and rotational motion of surfaces. In the first case, the spatial trajectory that must be performed by the node is described by one or more variables functions. Through the movement of surfaces, instead, a purely mathematical method is used, in which boundaries are defined in relation to rotation and translation of surfaces.

The main advantage of using the geometric method is the extreme precision of the procedure. Moreover, during the folding process, the rigidity constraint of the faces, imposed by the rigid motion, is also satisfied. The use of a strictly mathematical procedure is suitable for periodic patterns in which the single cell operation can be repeated "n" times in both planar directions. The method developed for the genesis of the Miura-ori pattern allows to use the height of the corrugation as a geometric variable for the kinematics, instead of the dihedral angle between two contiguous faces. This choice is motivated by design reasons: in structural design it is often more important to adjust the width of the corrugation than the inclination of the individual facets.

During the folding process, through simple trigonometric considerations, one can control the movement of the single unit by varying the height of the central point at the base cell. This operation ensures compliance with the Miura-ori constraints, such as rigid-foldability and flat-foldability. In Figure 3 the initial (a,b) and final steps (c,d) of the parametric genesis of planar (a,c) and curved (b,d) models are shown. The generalized method, followed for the generation of a barrel vault tessellated with Miura-ori pattern, has been derived from the procedure proposed by Dudte (2016) for cylindrical surfaces.

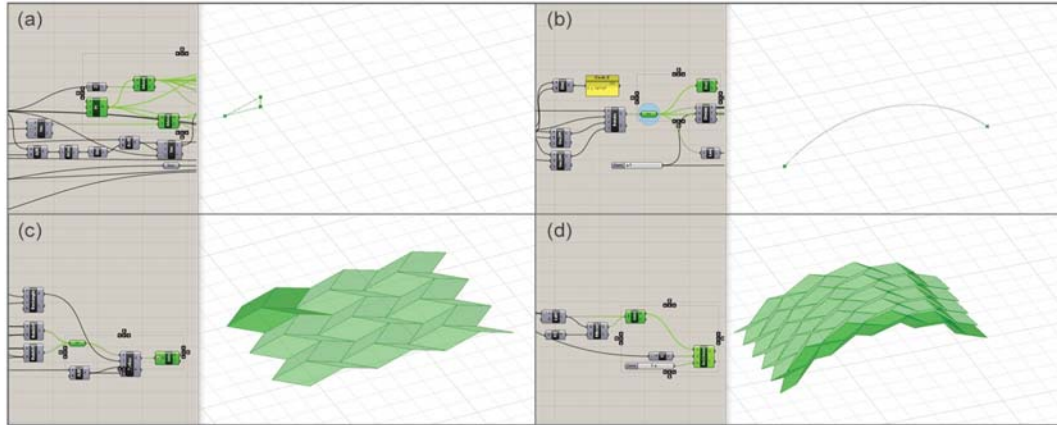

Figure 3. Parametric method for the Miura-ori pattern genesis: (a) trigonometric definition of a planar model, (c) final planar model, (b) curved base rail for the generalized model, (d) final curved generalized model.

## Kinematic performance assessment

The kinematic investigations pertaining to the designed origami-based adaptive planar and curved structures aim to identify and describe the geometry of the folding motion.

The two cases, planar and curved, are tackled by relying on different models: parametric-geometrical model and simplified analytical models consisting of 3D spatial truss structures.

The simplified Miura-ori analytical models are composed by rigid bars located along the folds directions, spherical hinges in place of the vertices and additional bars dividing the quadrangular facets into triangles; the latter assure the facet bending rigidity during both the loading and folding phases. The large displacement kinematics is studied in order to describe and predict the rigid folding movement of the origami assemblies. An equivalent von-Mises truss analytical model is derived in order to describe finite motions of a single Miura-ori modules characterized by rigid and flat-foldable panels.

The simplified analytical model of the basic module is built starting from the reference initial configurations of the vertices. By considering the point C as the reference fixed point, the positions of the remaining vertices are given by (Figure 4):

$$\begin{aligned}
 C_{(\varphi_0)} &= (0, 0, 0) \\
 A_{(\varphi_0)} &= \{\sqrt{2} \cos \varphi_0, 0, \sqrt{2} \sin \varphi_0\} \\
 B_{(\varphi_0)} &= \{2\sqrt{2} \cos \varphi_0, 0, 0\} \\
 A'_{(\varphi_0)} &= \left\{ \frac{\cos 2\varphi_0 \cdot \sec \varphi_0}{\sqrt{2}} \cdot \sqrt{\cos 2\varphi_0 + 1/2} \cdot \sec \varphi_0, \sqrt{2} \sin \varphi_0 \right\}
 \end{aligned} \tag{1}$$

$$A''_{(\varphi=s)} = \left\{ \frac{\cos 2\varphi_0 \cdot \sec \varphi_0}{\sqrt{2}} \cdot -\sqrt{\cos 2\varphi_0 + 1/2 \cdot \sec \varphi_0}, \sqrt{2} \sin \varphi_0 \right\}$$

in which is the arbitrary initial angle  $\angle A\hat{C}B$ . **Error! Bookmark not defined.**

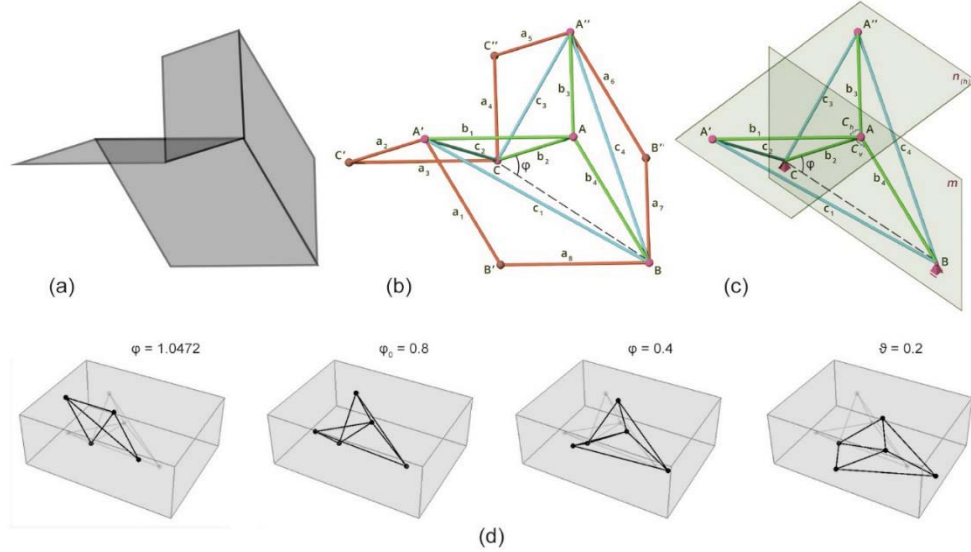

Figure 4. Simplified Miura-ori analytical models based on von-Mises truss analytical system: (a) quadrangular facets model, (b) corresponding 3D spatial truss structure, (c) simplified 3D spatial truss structure, (d) large kinematic displacements.

The nodal displacements of the reduced model are governed by the following equations,

$$v_A(\varphi) = \sqrt{2} \sin \varphi - 1, w_A(\varphi) = \sqrt{2} \cos \varphi - 1, w_B(\varphi) = 2(\sqrt{2} \cos \varphi - 1) \quad (2)$$

So that the final nodal positions of the reduced model are given by

$$C_{(\varphi=s)} = C_{(\varphi_0)}$$

$$A_{(\varphi=s)} = A_{(\varphi_0)} + (w_A, 0, v_A) = \{\sqrt{2} \cos \varphi, 0, \sqrt{2} \sin \varphi\}$$

$$B_{(\varphi=s)} = B_{(\varphi_0)} + (w_B, 0, 0) = \{2(\sqrt{2} \cos \varphi - 1) + 2, 0, 0\} \quad (3)$$

$$A'_{(\varphi=s)} = \left\{ \frac{\cos 2\varphi \cdot \sec 2\varphi}{\sqrt{2}}, \sqrt{-1/2 (\cos 2\varphi \cdot \sec \varphi)^2 - 2(\sin \varphi)^2 + 2}, \sqrt{2} \sin \varphi \right\}$$

$$A''_{(\varphi=s)} = \left\{ \frac{\cos 2\varphi \cdot \sec 2\varphi}{\sqrt{2}}, -\sqrt{-1/2 (\cos 2\varphi \cdot \sec \varphi)^2 - 2(\sin \varphi)^2 + 2}, \sqrt{2} \sin \varphi \right\}$$

The kinematic investigations address the behavior of both, classic and generalized Miura-ori tessellated surfaces. The surfaces are analyzed during the entire folding phase, gathering empirical curves describing the dependence of the variable dimensions of the overall covered area and the sides' length with respect to the pattern height and folding angles. Both the planar and curved Miura-ori tessellated surfaces showed to provide a suitable and convenient solution for realizing



developable structures. For the planar case, in any stage belonging to the red area in Figure 5, the Miura-ori pattern is able to cover a larger area than the corresponding simple one-way corrugation.

In the curved scenario, the projected area of the Miura-ori tessellated surface is always larger than the continuous counterpart (see Figure 6). In Figures 5 and 6, the evolution of the sides dimensions for varying heights is also shown. In particular, there is a close relationship between the orthogonal sides: during the first half of the folding pattern, the two sides length ratio is constant. In the planar case, when the system converges to the final completely folded configuration, the two sides length ratio tends to zero.

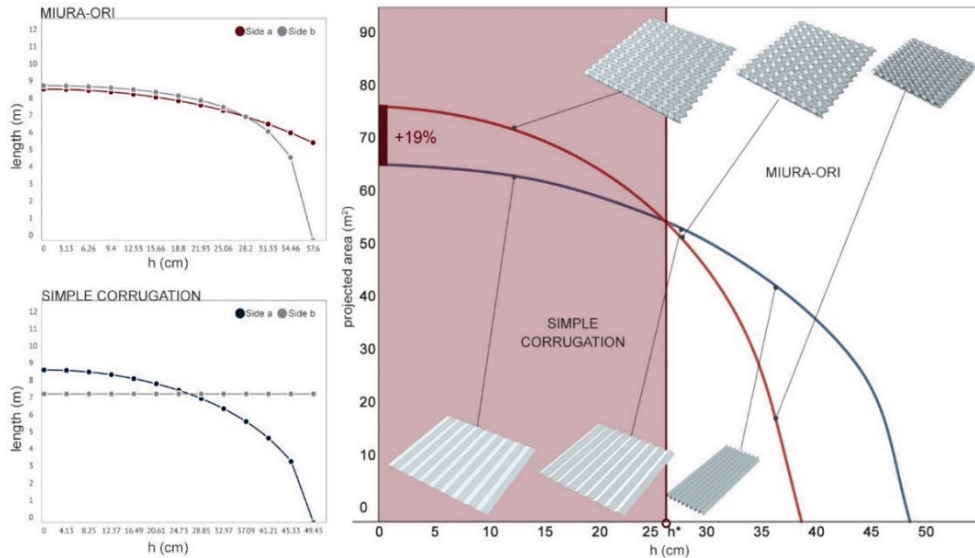

Figure 5. Geometric comparison between a planar Miura-ori tessellation and a simple corrugation plate: (a) side ratio  $a/b$ ; (b) projected area variation throughout the folding phase.

## Mechanical performance assessment

The mechanical investigations pertaining to the designed origami-based adaptive planar and curved structures aim to describe the structural performance by considering continuous origami-based models, i.e. models in which the facets are rigidly connected by the folds. The static analysis is carried via numerical finite element models (FEM). In the analysis different constraints and load configurations are considered. As far as the static behavior of planar systems, a comparison between a Miura-ori tessellated systems, and a simple, one-way, corrugation, with equivalent corrugation height and projected area, is carried out.

In particular, different boundary conditions are considered: supports along the entire edges, along two opposite sides and point support at the corners. The considered loading conditions include combinations of self-weight, distributed load projected on the horizontal plane, point loads in the center of the plate. In Figure 7a, as an example, the displacement field of a square plate under distributed vertical load is shown. As far as the static behavior of the vaulted systems, the FEM analysis concerns with the comparison between a generalized Miura-ori tessellated structure and the equivalent traditional shell structure. The considered loading and constraints configurations are analogous to the planar case; an example is shown in Figure 7b. The conducted numerical

study shows that the type of boundary constraints, either fixed or hinged, does not influence the global structural behavior.

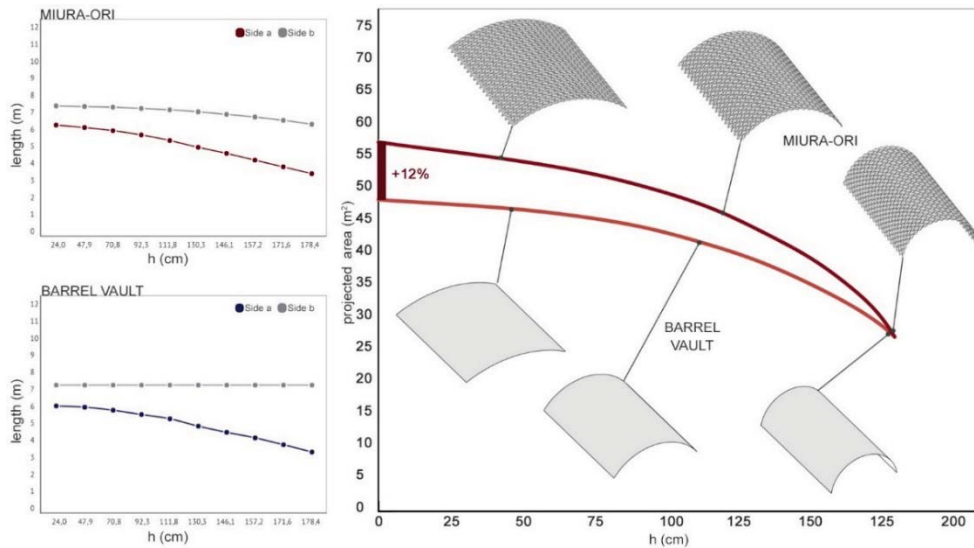
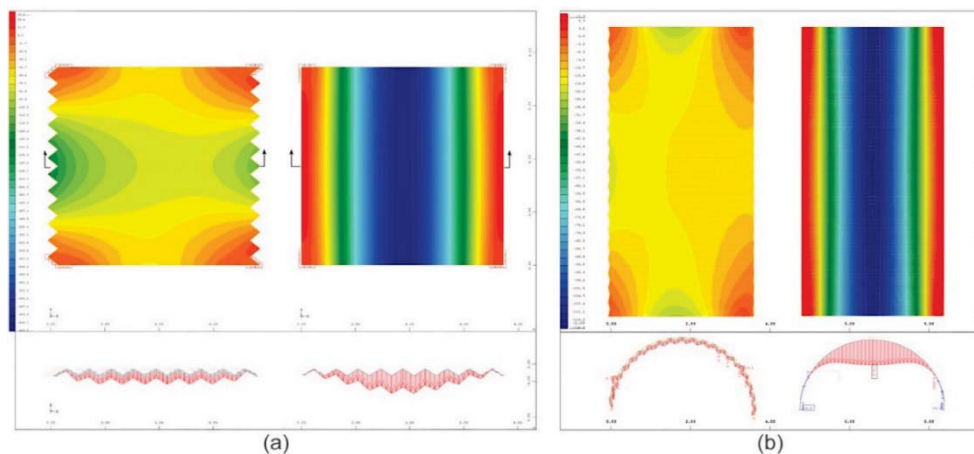

Figure 6. Geometric comparison between a curved Miura-ori tassellation and a barrel vault: (a) side ratio  $a/b$ ; (b) projected area variation throughout the folding phase.

It has a rather local effect, limited to the directly constrained modules. As far as planar systems, under all the considered loading conditions with fixed (or hinged) corners, the Miura-ori tessellated surfaces show a more efficient geometry for resisting bending moment than the simple one-way corrugated counterpart. Both planar and curved Miura-ori tessellated surfaces show an evident effective bidirectional behavior, due to the beneficial moment of inertia associated to the corrugation along both orthogonal directions of the plane.

Figure 7. Vertical displacement of Miura-ori tassellates models under uniformly distributed load: (a)



comparison between a planar Miura-ori tassellation and the corresponding simple, one way, corrugation, (b) comparison between a generalized Miura-ori tassellation and the equivalent continuum barrel vault.

## Experimental validation

The experimental phase aims to validate the theoretical results by testing physical scaled models. In particular, this phase is meant to identify the role played by manufacturing aspects that are difficult to model, such as the actual folding mechanism provided by cylindrical hinges and the actual thickness of the panels. Experimental tests aim to validate the theoretical static results and to identify the equivalent elastic properties of the creases realized by different cylindrical hinges. An experimental campaign based on static tests has been carried out at the Materials and Structures Lab at Sapienza. The tests have been conducted on a generalized Miura-ori model whose PLA (polyactic acid) modules have been 3D printed. The Miura-ori tessellated curved model, approximating a barrel vault geometry, is shown in Figure 8. By introducing the parameter  $\mu = \frac{f}{l}$  to identify the geometric features corresponding to different configurations, three models have been tested (Figure 8):

- model A:  $\mu=0,25$  and  $l=56\text{cm}$ ;  $h=14\text{cm}$ ;  $p=29\text{cm}$ ;
- model B:  $\mu=0,18$  and  $l=66\text{cm}$ ;  $h=11,8\text{cm}$ ;  $p=39\text{cm}$ ;
- model B:  $\mu=0,12$  and  $l=73\text{cm}$ ;  $h=8,8\text{cm}$ ;  $p=49\text{cm}$ .

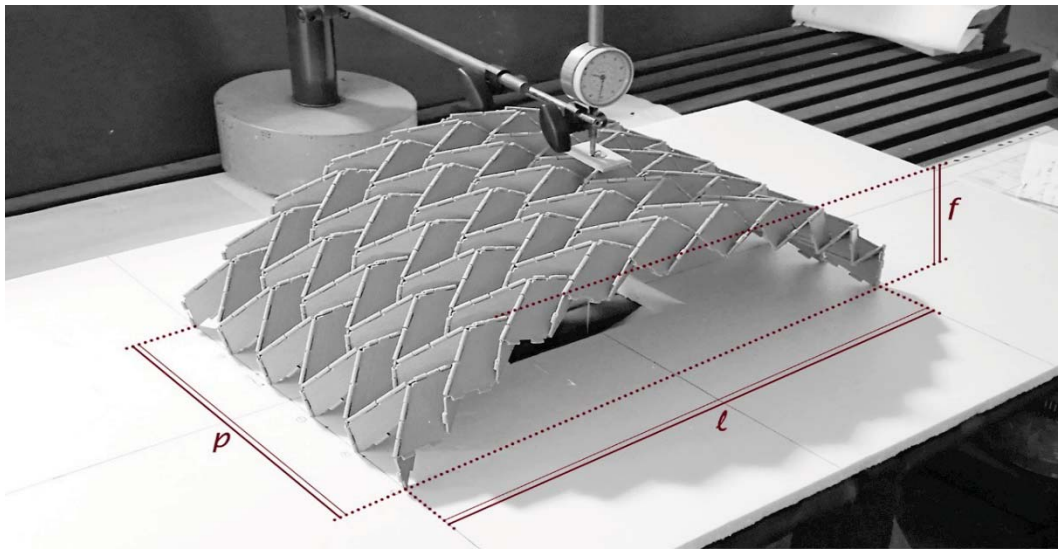

Figure 8. 3D printed tested model: the experimental analysis has been carried out on three different static configuration, varying the sagitta “f” of the bas.

The considered material properties are: Young modulus,  $E=3500$  MPa, density  $\delta=1240\text{kg/m}^3$ . The cylindrical hinges are realized through 3D printed tubes connected to the module edges in which a steel pivot is inserted. The overall weight of the model is  $P=947$  gr while the area of the origami surface is  $A=2440$  cm<sup>2</sup> and the panels thickness is 1.5 mm. The two edges with length  $p$  are fixed to the base to realize a clamped constrain. A point load is applied by suspending with a wire metallic masses from the middle point of the vault. In the same position, a Käfer precision dial gauge was used to measure the vertical displacement (Figure 9) under different loading levels. The results reported in Figure 10a show the comparison between the force-displacement curves obtained experimentally and the same curves obtained with an equivalent FEM model in which a model updating is performed by tuning the linear rotational stiffness of the

cylindrical hinges. Starting from the configuration with the largest sag-to-span ratio ( $\mu=0,25$ ), a rotational stiffness  $\rho = 9 \text{ N/rad}$  is identified; increasing the folding angle ( $\mu=0,18$ ), the rotational stiffness decreases to  $\rho = 1 \text{ N/rad}$ , before increasing again to  $\rho = 9 \text{ N/rad}$  in the lowest configuration ( $\mu=0,12$ ). In Figure 10b the experimental loops representing the loading and unloading paths for the three configurations are shown. A rather clear hysteretic behaviour can be observed which is to be ascribed to the friction of the cylindrical hinges. Both figures As expected, both figures confirm that the global vault stiffness decreases with the sag-to-span ratio.

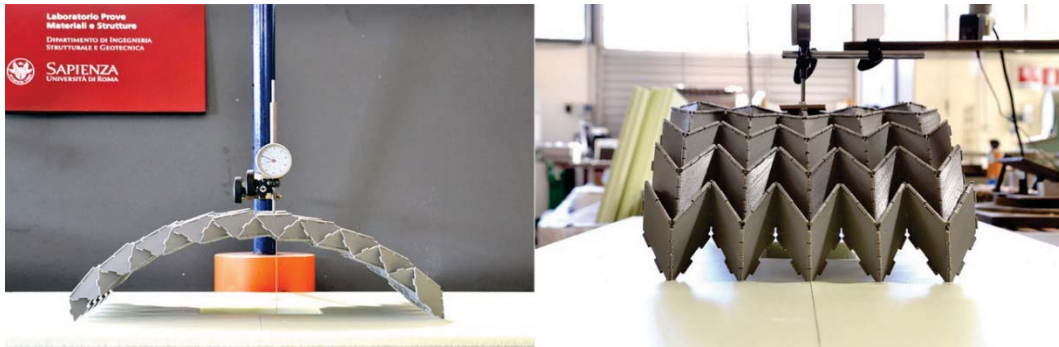

Figure 9. Deformed configuration of the Model A: under the maximum loading condition the transversal view of the model shows the expected saddle-shape.

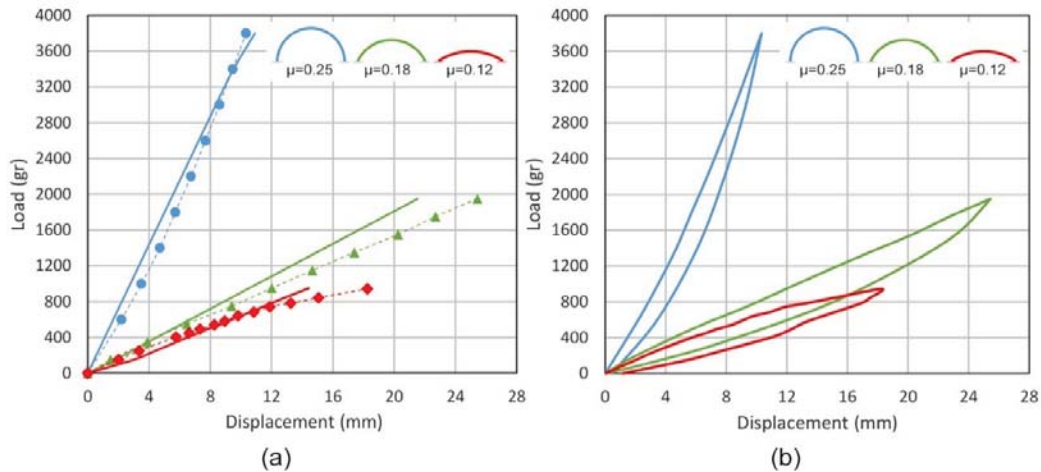

Figure 10. Experimental results of physical model displacement analysis: (a) comparison between experimental model and FEM equivalent model throughout the loading phase, (b) comparison between three different model, with variable  $\mu$ , throughout the loading and unloading phase.

## Conclusions

This study addresses the mechanical behavior of plate and shell structures based on origami patterns in different geometric configurations. The kinematic and static behavior of these structures is investigated by combining numerical, analytical and experimental tools. While ideal cylindrical hinges are considered in the analytical reduced model undergoing finite-displacement kinematic,

continuous origami configurations are used in the FEM based static simulations. In the experimental study, the actual fold mechanical role is identified by means of an equivalent elastic rotational stiffness of the FEM model cylindrical hinges.

From a kinematic point of view, the advantages of the Miura-ori tessellation in terms of covered area for a given corrugation amplitude were shown through parametric investigations concerning with planar and curved geometries.

From the static viewpoint, it is found that the influence of the type of boundary conditions decays rapidly with the distance from the origami edges. As far as planar systems, under all the considered loading conditions with fixed (or hinged) corners, the Miura-ori tessellated surfaces show an efficient form-resistant behaviour. The latter takes also advantage of the favorable moment of inertia associated to the corrugation along two orthogonal directions.

The experimental campaign allowed to overcome the modeling difficulties related to the actual folding mechanical behaviour. A simplified linear elastic identification was carried out to derive a numerical model capable of capturing the main aspects of a Miura-ori tessellated vault. The experimental results have shown a clear nonlinear hysteretic behaviour of the folds. These aspects are currently addressed in on-going research activities.

## Bibliography

Tachi T., "Geometric Considerations for the Design of Rigid Origami Structures", in *Proceedings of IASS Symposium 2010*, pp. 771-782, Shanghai, China.

Schenk M., Guest S.D., "Origami Folding: A Structural Engineering Approach", *Origami 5:5OSME*, eds Wang-Iverson P, Lang RJ, Yim M (CRC, Boca Raton, FL), pp 291-303.

Schenk M., Guest S.D., "Geometry of Miura-folded metamaterials", *Proc. Natl. Acad. Sci. U.S.A.* 110, 3276–3281, 2013.

Reis P.M., Jiménez F.L., Marthelota J., "Transforming architectures inspired by origami", *Proc Natl Acad Sci USA*, 112:12234-12235, 2015.

Filipov E.T., Tachi T., G.H. Paulino G.H., "Origami tubes assembled into stiff, yet reconfigurable structures and metamaterials", *Proc Natl Acad Sci USA* 112:12321– 12326, 2015.

Chen Y., Peng R., You Z., "Origami of thick panels", *Science*, 349, 396–400, doi: 10.1126/science.aab2870, 2015.

Cheng Lv, et al., "Origami based Mechanical Metamaterials", *Scientific Reports*, 4:5979, doi: 10.1038/srep05979, 2014.

Kuribayashi, K. et al. "Self-deployable origami stent grafts as a biomedical application of Ni-rich TiNi shape memory alloy foil", *Mater. Sci. Eng. A-Struct. Mater. Prop. Microstruct. Process.* 419, 131–137, 2006.

Gardner J.P., et al., "The James Webb space telescope", *Space Sci. Rev.* 123, 485–606, 2006.

Cromvik C., Eriksson K., "Airbag folding based on origami mathematics", Chalmers University of Technology, Goteborg, 2006.

Miura K., "Fold, its physical and mathematical principles", *Origami Science and Art: Proceedings of the Second International of Origami Science and Scientific Origami*, pp. 41-40, Japan 1997.

Miura K., "Method of packaging and deployment of large membranes", *The Institute of Space and Astronautical Science*, Rep. 618, 1985.





You. Z, Wu W., "A solution for folding rigid tall shopping bags", *Proc. R. Soc. A*, 467, 2561–2574, 2011.

Dudte L. H., Vouga, E., Tachi T., & Mahadevan L., "Programming curvature using origami tessellations", *Nat. Mater.* 15, 583–588, 2016.



# Adaptability in the Built Environment Through The Use of Transformable Architecture

An exploration into the architectural *why* and engineering *how*

Mia Tsiamis<sup>1</sup>, Ryan Haselman<sup>2</sup>

<sup>1</sup>Leslie E. Robertson Associates, United States, <sup>2</sup>Parsons School of Design, USA

<sup>1</sup>mia.tsiamis@lera.com, <sup>2</sup>ryanhaselman@gmail.com

**Abstract.** Buildings are conceived as permanent-use structures, generally designed for a set function. However, dynamic markets and fast-changing societies require new accommodation and usually buildings are deconstructed and rebuilt to suit new uses before the technical life cycle of the building materials has expired and thus they are not used to their fullest potential. The solution is to anticipate the diversity of needs that are either dictated by the building's users, or by the changing social and economic market, and to provide a design that can adapt to these evolving demands. A flexible design not only increases the longevity of a building, but on a shorter timescale, enables the building to be multi-functional, serving a wider community of people. This flexibility can be achieved by means of transformable structures which can change shape, volume, or appearance, subsequently impacting how a space is used or experienced. In order to inspire a shift towards flexible design, the research seeks to expose the architectural "why" and the engineering "how" of transformable architecture by analyzing existing projects and exploring technical strategies for realizing transformable structures. A qualitative evaluation of existing transformable architecture projects is provides the context for experimenting with bistability as a potential mechanism for building transformable architecture. Digital and physical modelling reveals limitations and opportunities associated with designing movable structures with this type of mechanism.

**Keywords.** *Transformable Architecture; Bistability; Architectural Design; Parametric Modelling.*

## Introduction

As the greatest investment supporting human activity, the built environment should be as efficient as possible, adapting to our changing needs. Transformable architecture is part of a family of time-based architecture typologies, including flexible, adaptable, and interactive architecture which are characterized by the ability to change over time. Transformable architecture has many benefits. It promotes both the short-term and long-term re-use of a building or space, thus reducing consumption of resources and production of waste. It can make spaces customizable to a variety of users and it enables the same space to be reused for multiple purposes. As the global community continues to grow, sharing spaces and the flexibility to adapt to changing user groups, as well as environmental, social, and economic conditions, will become increasingly more valuable. Transformability in the built environment "creates a more democratic form of architecture" that encourages interaction rather than reaction.

### ***The basics: Transformation fundamentals***

Before exploring the challenges and values of transformable architecture, it is important to establish a working definition for this type of architecture. Transformable architecture is part of a family of time-based architecture typologies, including flexible, adaptable, and interactive architecture. These types of architecture are characterized by the ability to change over time, but

can be differentiated from each other according to the timescale of this change. In the context of architectural design,

- *flexible* spaces are often continuous flowing volumes that can be easily modified and reconfigured to meet the requirements of a variety of functions. Flexible architecture accommodates small changes that are predetermined by the user's desires or needs, and which occur frequently, for example, converting a living space into a working space. The change is driven by the user.
- *adaptable* refers to the ability of the built environment to evolve over time and remain useful in changing conditions. This suggests a slower change that is driven by changes in the environment (i.e. seasons), or changes in the collective behavior of the building's occupants. The change is more on an evolutionary scale and enables a response to possibly unexpected changes.
- *interactive* refers to an immediate feedback loop between the built environment and the user. Changes are driven by sensor input and translated to an almost immediate actuation.
- *transformable* describes the ability to change, and change back to the original state, referring to a cyclic timescale. It is a way to achieve the other three types in that it can respond to short-term fluctuations in the individual user's needs or a temporary climate, or it can achieve long-term change to meet new criteria. The transformation can be a physical movement (expansion, contraction, translation, rotation, inflation, etc.) or a change in the visual appearance of surfaces (i.e. media façade, lighting, etc.). Transformable architecture is indeterminate architecture having variable geometry, which can be reshaped in response to the changing needs of the user. The building is a mechanism and the designer defines a predetermined range of changes (Rosenberg 2010).

According to the "Shearing Layers of Change," the layers of a building (interior stuff, space, services, structure, and skin) have varying lifecycles, as illustrated in Figure 1. Timescales of change vary from the interior to the exterior of a building, where the interior stuff changes faster or more frequently than the exterior skin (Lee, 14), making the interior flexible, and the exterior adaptable, according to the definition above. Most transformable architecture occurs in the space layer, which includes walls, floors, and ceilings, or in the skin layer, referring to the façade.

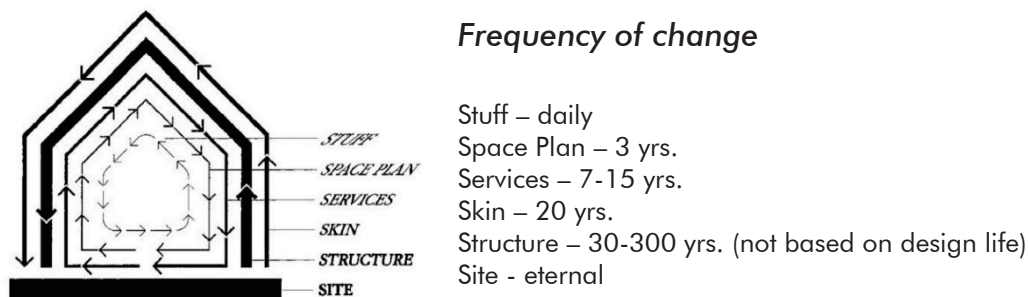

Figure 1. Stewart Brand's "Shearing Layers of Change" (1994) (Source: Lee 2012, 14)

As summarized by Robert Kronenburg, author of numerous texts on adaptive and flexible architecture:

"Truly transformable architecture...must enable a dramatic alteration in the character of the whole architectural environment. A transformable building is therefore one that changes shape, volume, or appearance by the physical alteration of structure, skin or internal surface, enabling a significant alteration in the way it is used or perceived." (Kronenburg 2007, 146)



### The Evolution

The earliest form of transformable architecture is the tent. The tent facilitated the nomadic lifestyle of early humans who traveled with the seasons. The flexibility and transportability of the tent structure aided our ability to adapt to changing conditions in the environment. This adaptability is the key to the success of humanity. Fast-forwarding to the modern era, examples of transformable architecture, such as Gerrit Rietveld’s Schroder House, and Mies van der Rohe’s Villa Tugendhat, suggest that flexibility seemed to be more of a luxury during that period. Having options for how the building could be experienced and the ability to customize a space was valued greatly by the users, but it was not a necessity. However, as the world population and the demand on resources continue to grow, flexibility will again become critical to the success of humanity and transformable structures will offer a standard solution to adaptable living.

A review of transformable buildings from the early modern period reveals transformability in the built environment was achieved primarily through the use of flexible partition walls, collapsible stairs, and walls and roofs that opened to the exterior. Gerrit Rietveld’s Schroder house, built in 1924, is an early example of modern transformable architecture that used walls that slide on tracks and fold to convert the first floor from an open living room in the day to closed bedrooms at night, as seen in Figure 2. The adaptability of the design allowed Truus Schroder to personalize and optimize the use of her house, enabling her “to live in the active sense and not be lived.” Villa Tugendhat, designed and built by Mies van der Rohe in the Czech Republic between 1929 and 1930, focused on functional amenities, and included an exterior glass wall which could be retracted into the foundation using electric motors, to completely open the interior space to the exterior environment, as seen in Figure 2. This “disappearing wall” made the impressive view from the house an integral part of the interior and made this unification of interior and exterior a customizable experience. A more progressive approach to flexible design was taken by architect Cedric Price who sought the use of “impermanent, improvisational, and interactive systems” to make architecture adaptable to rapidly changing social and economic conditions. Following up on his concept for the *Fun Palace*, a reconfigurable building which used travelling cranes to move building elements (depicted in Figure 2), in 1966, Price published his proposal for the *Potteries Thinkbelt*, a new type of university for science and technology, composed of a network of mobile classrooms, faculty buildings, labs, and student housing, organized along the abandoned rail infrastructure of the Potteries region. The container-style building units could be lifted by crane and moved by rail offering the ability to reconfigure the facilities according to the needs of the institution. Unfortunately, neither of these projects was realized.

Schroder House



Source: (Arch Daily, 2010)

First floor, walls extended

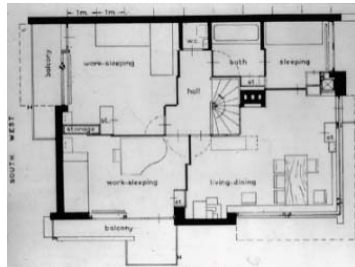

Source: (Modern Architecture, UPenn, 2001)

First floor, walls folded



Source: [www.arthistory.upenn.edu/spr01/282/w6c1i12.htm](http://www.arthistory.upenn.edu/spr01/282/w6c1i12.htm)



Villa Tugendhat



Source: <http://www.tugendhat.eu/en/photogallery/photogallery-2010.html>

Fun Palace

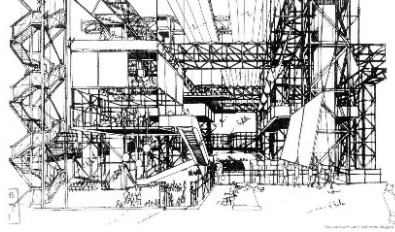

Source: <http://www.worldarchitecturennews.com/project-images/2012/21461/cedric-price/reader-review-fun-palace.html?img=1>

Potteries THINKBELT

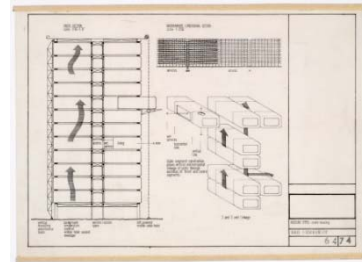

Source: <http://discoversociety.org/2014/07/01/the-thinkbelt-the-university-that-never-was/>

Figure 2. Examples of transformable architecture from the early 20<sup>th</sup> century.

More recent transformable structures and buildings explore beyond the movable partition and retracting roof and experiment with new mechanisms of movement, new materials, and more complex forms. The Prada Transformer by OMA, shown in Figure 3) brings Cedric Price's *Thinkbelt* project to life in the sense that it uses external cranes to lift and rotate an entire pavilion, which serves a different purpose in each of four possible orientations. The Sharifi-ha house by Nextoffice (Figure 4) expands upon the idea of unifying interior and exterior that was achieved by the "disappearing wall" of Villa Tugendhat, by sliding and rotating an entire room to expose it or close it off from the outside environment. The Hoberman arch takes the concept of sliding elements, like the movable walls in the Schroder house, and adds a level of complexity, by creating a system of 96 panel that are hinged together to create a rigid curtain, and slide over each other to reveal or hide the stage behind, as seen in Figure 5. These projects, along with many others, such as Santiago Calatrava's L'Hemispheric and (Figure 6), are testing the limits by scaling up transformations that are readily achievable on the small scale, to see what is possible on the building scale.

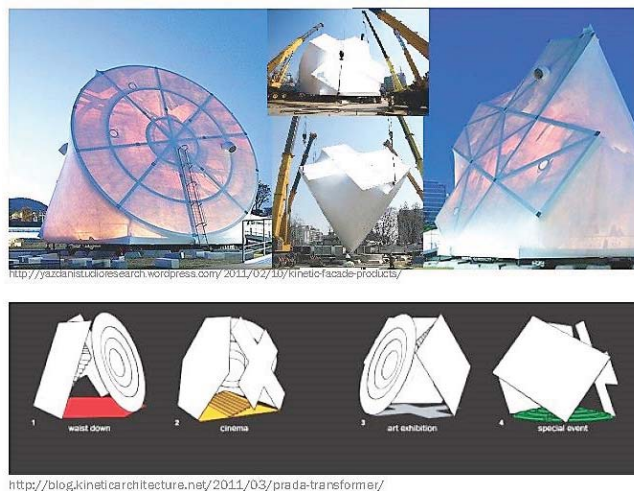

Figure 3 Prada Transformer by OMA, Seoul, Korea, 2009.





<http://www.archdaily.com/522344/sharifi-ha-house-nextoffice/>

Figure 4. Sharifi-ha House by Nextoffice, Tehran, Iran, 2013.

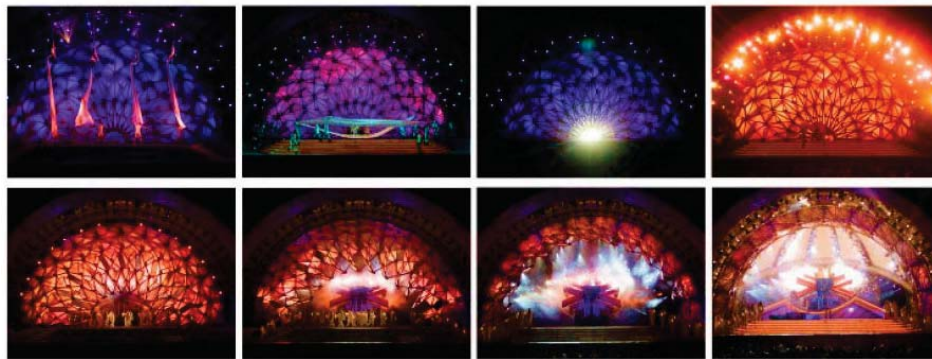

<http://www.snipview.com/q/Hoberman%20Arch>

Figure 5. Hoberman Arch by Chuck Hoberman, Salt Lake City, Utah, United States, 2002.



<http://firstmonday.org/ojs/index.php/fm/article/view/1563/1478>

Figure 6. L'Hemisfèric by Santiago Calatrava, Valencia, Spain, 1998.

## Evaluating the Precedents

As we can see from the aforementioned projects, transformable architecture is definitely not a new concept. However, transformability seems to be something that architects/engineers/designers dabble in but do not commit to as a design strategy. What is holding it back from becoming 'mainstream'? Based on our research, the most common obstacles are related to the stability of the system, in terms of maintenance, scale, and reliability. The complexity of the design, in terms of geometry, number of movable parts, type of mechanism, mode of operation (hand powered or electrically powered), type of building element, and stages of transformation, pose challenges to the maintenance of the system. The ability to maintain the structure is linked to its reliability. "The mechanisms employed to enable movement to take places should be robust, maintenance free, easily operable and reliable." The issue of scale lies in the challenge of applying the principles of movement that we commonly see in smaller element such as garages, windows, and shading systems to larger spans and structures.

### Scale

One of the biggest issues in designing a transformable structure is scale. Most common kinetic structures, such as garage doors, windows, gates, collapsible canopies, louvers, or even certain toys and household products, are small. While scaling up the movement principles of these structures and products to the building scale is theoretically feasible, the design of large building components over bigger spans poses a challenge. Furthermore, "...the expertise lies elsewhere for this work – it's in bridges and marine work for the large scale and the small scale lies in mechanical engineers/kinetic artists so it's sometimes difficult for building engineers to bridge that gap." (Rob Otani, CORE Studio, Thornton Tomasetti)

## Reliability

Concern about the reliability of a transformable structure seems to be the main source of hesitation of designers and clients considering a moveable system. “The mechanisms employed to enable movement to take places should be robust, maintenance free, easily operable and reliable.” (Kronenburg 2007, 146). For movable bridges, such as the Bridge over the Inner Harbor Duisburg (Figure 7), design codes generally require that the bridges are guaranteed to be fully operable for a specified number of days throughout the year (Edwin Thie, Senior Engineer, Arup). Redundancy in the system of movable parts can improve reliability. As suggested by the following example, a system whose moveable parts are connected in series rather than in parallel faces the possibility of failure of the entire system if only one part fails. According to structural engineer Daniel Brodtkin of Arup, who was involved in the engineering design of Chuck Hoberman’s Iris Dome (Figure 8), “...another obstacle was that the Iris Dome has a large number of joints that must always work properly in support of a single degree of freedom system. One local failure and your roof is stuck open!” (Daniel Brodtkin, Arup).

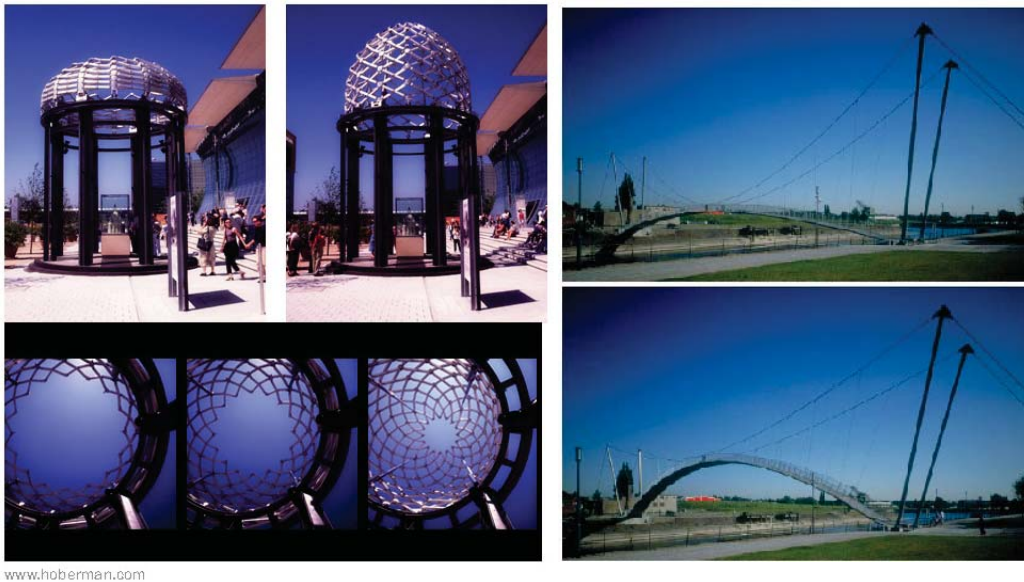

Figure 7. Iris Dome by Chuck Hoberman, Hanover, Germany, 2000 (left; Footbridge over the Inner Harbor Duisburg by Schlaich, Bergermann and Partners, Duisburg, Germany 1999 (right.)

Transformable architecture has the power to improve spatial quality, improve environment, or improve experience. This is something that a static structure cannot offer. In order to inspire a shift towards transformable buildings, we must develop a trust in their reliability and advantages. This starts with collecting and evaluating existing projects and lessons learned from these projects as well as gathering the planning and technical resources that can guide designers in the realization of transformable projects.

A survey of about 50 architectural projects that incorporate transformable elements was carried out. For each of these projects, the following questions were answered:

1. What – building type, program, size, what moves and by how much
2. Why does it move?
3. When – frequency of change, how long the transformation takes
4. How – mechanism used, input force/power vs. weight of structure



Table 1. Reference Projects				
PROJECT NAME	ARCHITECT/DESIGNER/ENGINEER	LOCATION	YEAR	MOVABLE PART
Aerial Assemblies	Skylar Tibbits	MIT Self-Assembly Lab	2014	Floating balloons within a light frame.
Bengt Sjostrom Starlight Theater	Studio Gang Architects	Rockford, Illinois, USA	2003	Roof
Carlos Moseley Music Pavilion	FTL Design Engineering Studio	New York, USA	1991	Pavilion
Courtyard City Hall Vienna	Schlaich, Bergemann and Partners	Vienna, Austria	2000	Roof
Curtain Wall House	Shigeru Ban	Tokyo, Japan	1995	Façade
Decibot	Skylar Tibbits	MIT Self-Assembly Lab	2009	Modular units
Dutch Pavilion Venice Biennale 2012	Petra Blaisse, Inside Outside	Venice, Italy	2012	Curtain/wall
Ernsting's Family Distribution Depot	Schilling Architekten	Germany	1999	Roof
Evolution Door	Klemens Torggler	Austria	2014	Two panels which form a door
Floirac House	Rem Koolhaas OMA	Bordeaux, France	1995	Room
Footbridge over the inner harbor Duisburg	Schlaich, Bergemann and Partners	Duisburg, Germany	1999	Bridge
Fukuoka Housing	Steven Holl	Fukuoka, Japan	1991	Wall
Fun Palace	Cedric Price	Unrealized	1960-1961	Pod
Green Flea Pavilion	Buro 213	Potsdamer Platz, Berlin	1999	Pod
Hoberman Arch	Chuck Hoberman	Salt Lake City, Utah, USA	2002	Wall
House No 19	Korteknie Stuhlmacher Architekten + Bik Van der Pol	Utrecht, NL	2003	Wall
Iris Dome, Expo 2000	Chuck Hoberman	Hanover, Germany	2000	Scissor pair
Kuwait Pavilion Expo 92	Santiago Calatrava	Seville, Spain	1992	Roof
Laboshop	Mathieu Lehanneur	Paris, France	2008	Furniture





L'hemisferic	Santiago Calatrava	Valencia, Spain	1998	Wall/gate
Living Room	Formalhaut	Gelnhausen	2005	Room
Matsumoto Performing Arts Center	Toyo Ito	Japan	2004	Ceiling
Merchant Square Bridge	Knight Architects	London, W2, UK	2014	Bridge
Meridian Buildings	Joachim Kleine Allekotte Architekten	Potsdam, Germany	2004 (renovation)	Façade
MIT m-cubes	John Romanishin, Daniela Rus, and Kyle Gilpin	MIT	2013	Modular robotic cube
Modular bench	Beyond Standards		2010	Bench
Naked House	Shigeru Ban	Japan	2000	Room
Nine-Square Grid House	Shigeru Ban	Hadano, Japan	1997	Wall
One Ocean Pavilion, Expo 2012	soma	Yeosu, South Korea	2012	Façade
Palatinate Cellar	Santiago Calatrava	St. Gallen, CH	1999	Floor
Prada Transformer	Rem Koolhaas OMA	Seoul, Korea	2009	Pavilion
Quba Mosque Umbrellas	SL Rasch	Medina, Saudi Arabia	1992/2011	Shading
Reclamebureau, Lifting table	ZW6	Haarlem, Netherlands		Table
Rolling Bridge	Heatherwick Studio	London, UK	2004	Bridge
Roundabout house	Bohumil Lhota	Velke Hamry, Czech Republic	2002	Container/pod
Rubiks snake toy	N.A.	N.A.	N.A.	Modular units
Schroder House	Gerrit Rietveld	Utrecht, Netherlands	1924	Wall
Self-Assembly Chair	Skylar Tibbits	MIT Self-Assembly Lab	2014	Modular construction units
Sharifi-ha house	Nextoffice	Tehran, Iran	2013	Room
Sliding House	dRMM Architects	Suffolk, East Anglia, UK	2009	Façade
Sosia Sofa	Emanuele Magini		2011	Entire form
Spielbudenplatz	Consortium Spielbude Fahrbetrieb Hamburg, Lutzow 7 Garten- und Landschaftsarchitekten and Spengler Wiescholek Architekten und Stadtplaner	Hamburg, Germany	2006	Pavilion





Studio 8	Gruppe OMP	Rastede	2001	Wall
Ruhrtriennale Traversing stage	Bumat (manufacturer)	Germany		Seating
TurnOn	AllesWirdGut Architekten		2000	Room
University of Phoenix Stadium	Eisenman Architects	Glendale, Arizona, USA	1997- 2006	Roof/floor
Valhalla	Rudi Enos	Sheffield, UK	1999	Roof
Venezuelan Pavilion Expo 2000	Fruto Vivas, SL Rasch	Hanover, Germany	2000	Roof
DSSI Elementary School	Daniel Valle Architects	Seoul, Souh Korea	2016	Wall
Exocet	Designarium	Montreal, Canada	2015	Chair
Transformable Meeting Spaces	MIT Self-Assembly Lab, Google	Boston, Massachusetts	2016	Wall
Transformable Table	Boulon Blanc	Paris, France	2016	Table
aeroMorph	MIT Media Lab	Boston, Massachusetts	2016	Material
Metamaterials	Hasso Plattner Institute	Potsdam, Germany	2016	Material
Open House	Matthew Mazzotta	Alabama, United States	2013	Wall
La Caja Oscura	Javier Corvalan	Paraguay	2013	Roof/Walls
Live Projects	Students, University of Brighton	London, England	2016	Entire structure
Undefined Playground	B.U.S Architecture	Seoul, South Korea	2016	Entire structure
Humble hostel	Cao Pu	Beijing, China	2015	Wall

A database of these references was created to compare projects within the categories listed in Table 1 in an effort to uncover trends which may provide insight into the current state of transformable architecture and help define potential areas of development.

MOVEMENT	ACTUATOR	PURPOSE	SCALE	FREQUENCY
bend/rotate/pivot	cranes	artistic/experiment	small (i.e. furniture)	User preference - frequent
expand/stretch	electric motor	changing spatial configuration	medium (i.e. wall/ceiling/floor)	Daily
fold	hydraulic	climate control	large (i.e. building or bridge)	Weekly



free	magnets	open/close/access		Monthly/Seasonally
lift	manual	shapeshifting material		Event - infrequent
slide/roll	inflation	change functionality		

The frequency of occurrence of each category and various combinations of categories was tabulated and plotted, as shown in Figure 9. Several conclusions can be drawn from these graphs.

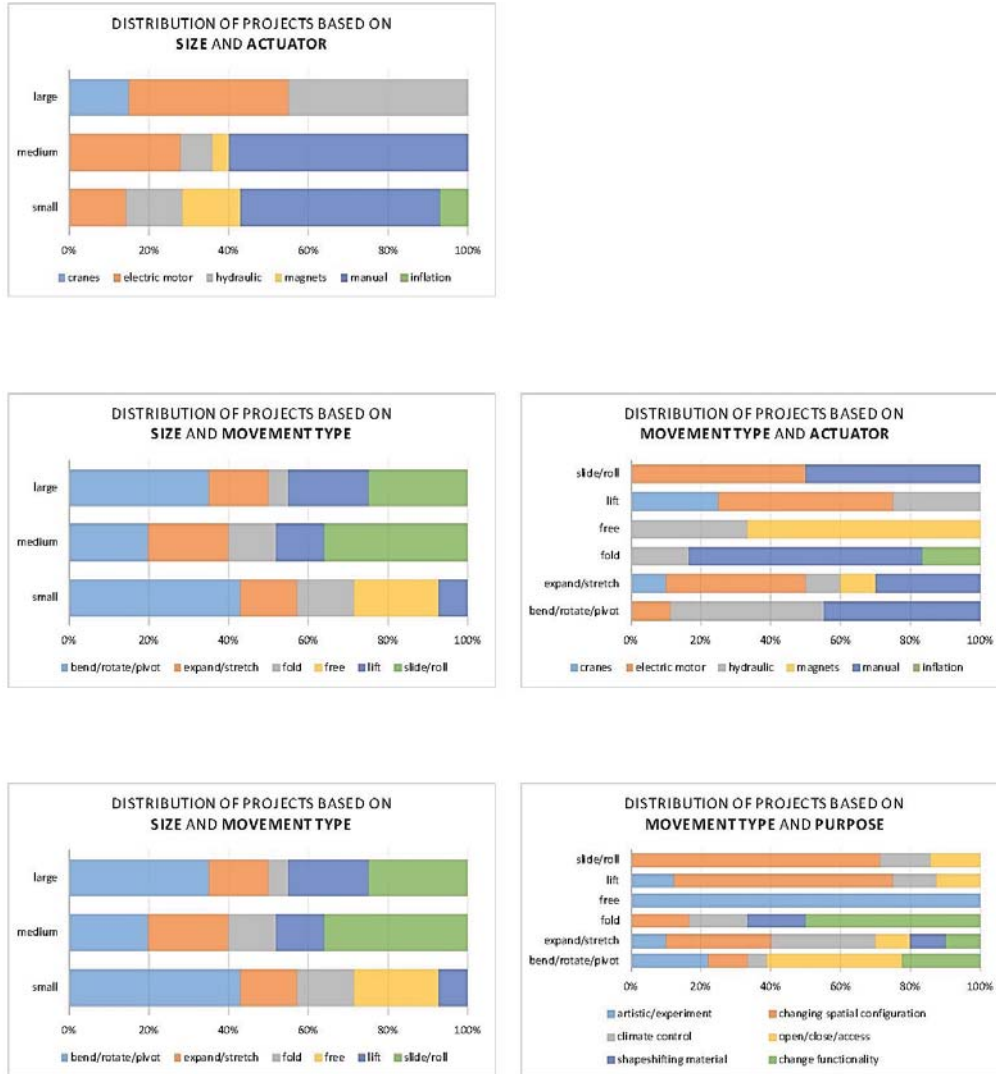

Figure 9. Evaluation of reference projects.

The most common reason for incorporating transformable elements into a project is the need or desire to be able to vary spatial configurations within a building. This change usually accommodates a change in program or user group. The second most common reason is the need

or desire to change the boundary of a space in order to provide or limit access to the space or to merge interior and exterior space. A majority of the projects that were surveyed used rotational movement or pivoting to achieve transformations. This rotational motion was primarily controlled by a hydraulic actuator or manually driven. The next most common type of movement is sliding or rolling, which is primarily controlled by electric motor or manually driven. Transformation in most medium sized projects is actuated by manual operation, while electric motor or hydraulic actuators are used to driven the transformations of larger scale architectural elements. However, overall, the most common actuation method is manual operation.

## Mechanisms for Transformation - Exploring Bistability

Connections are critical for both the stability and the flexibility of a movable structure. They must be flexible in order to allow movement, but they must also be able to lock into a static position after the transformation has occurred (De Marco Werner 2013, 51). This challenge was encountered in a previous project. The project was an interactive wall that changed shape when approached by users. The wall was designed as a 3D space truss and a 1:1 prototype was built using rigid aluminum struts connected by flexible rubber joints to allow for movement. Each module of the space truss had one telescoping element. Movement was achieved by lengthening certain telescoping elements as shown in Figure 10. The structure was stable in the static condition, but the rubber connections were too flexible and could not be locked out, thus causing instability when certain movements caused excessive deformations. Reflecting on this project, it became clear that a major challenge in designing transformable structures is finding the balance between stability and flexibility.

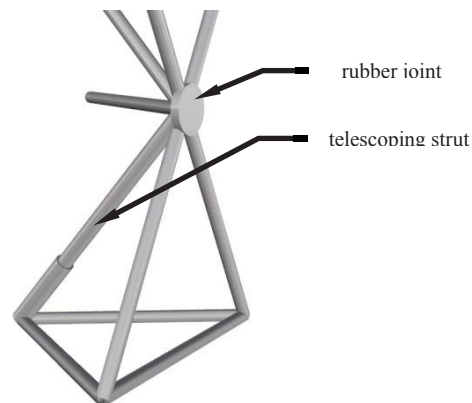

Figure 10. Interactive wall 1:1 prototype (left); Unit module of 3D space truss (right).

### Exploring Bistability

A bistable mechanism demonstrates the ability to change shape, and then “lock out” in two (or more) stable positions. For this reason, bistable mechanisms were explored further as potential candidates for actuating movable architecture.

In a bistable system, the flexibility to change shape/configuration depends on the stiffness and configuration of spring elements. In the stable states, the spring is “at rest.” During the transition from one stable state to the other, the springs undergo temporary compression and then “pop” into a stable state. Figure 11 illustrates this transition. Movement is driven by the natural tendency of the spring elements to reach the “rest state.”

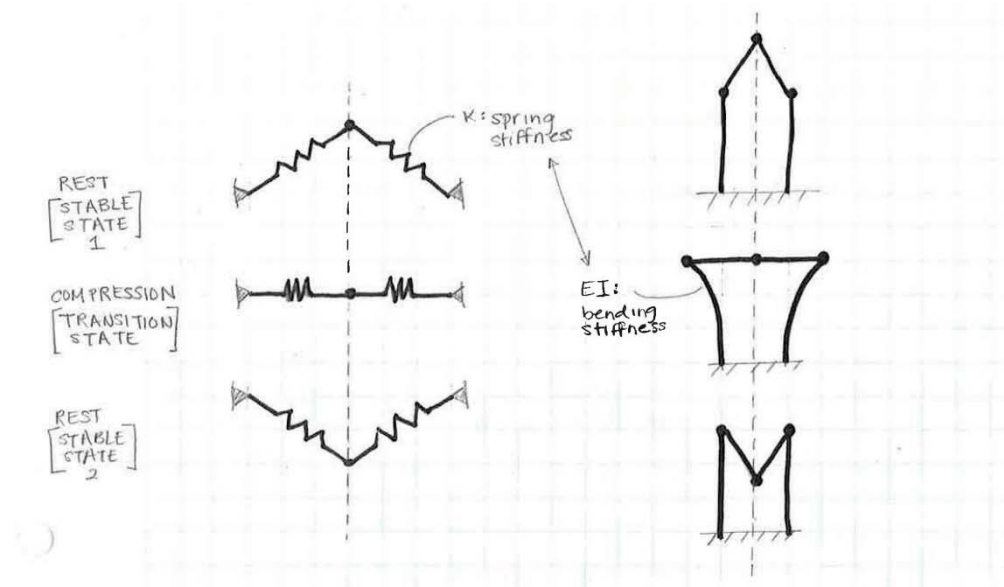

Figure 11. Schematic representation of bistable mechanism and transition between stable states.

Based on these principles the bistable system shown in Figure 9 was designed. In this system, the slender wooden strips represent the spring elements, and the bending stiffness plays the role of the spring. Therefore, the length, cross-sectional dimensions (used to calculate  $I$ , the moment of inertia), and the modulus of elasticity ( $E$ ) of the material of the strips, dictates the stiffness of the system. The mechanism is activated by applying a force to the node at which all strips terminate, to push it through the “stressed” or flexed state, and pop it into the other rest state.

A parametric digital model was developed to simulate the movement of the mechanism. In this model, the bending of the rods was simulated according to the behavior of a cantilevered beam, as demonstrated in Figure 12. By setting the maximum deflection equal to  $m$ , the extension beyond the hinge, the force that is required to achieve this deflection was back calculated and then used to determine deflections at increments along the strip.

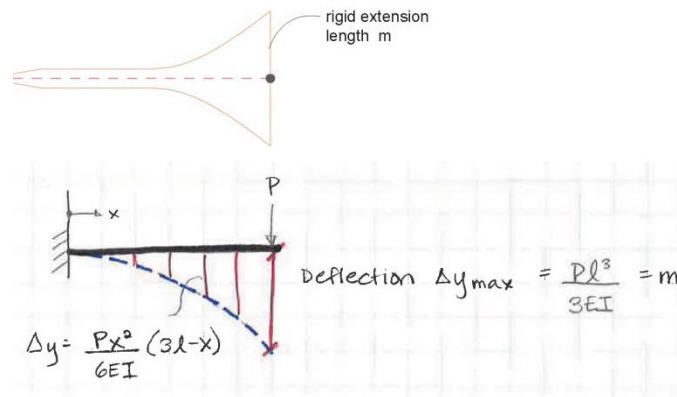

Figure 12. The beam formula for a cantilevered beam was used to generate a digital simulation of the mechanism.

A small scale prototype of the mechanism was fabricated in order to gain a better understanding of how the geometric parameters of the design affect the movement of the mechanism. The model was built using 3 strips of wood (pine) in a tripod configuration as the bendable elements, as shown in Figure 14. The rigid extensions, which are also wood (pine), are pin connected to the bendable strips. The rigid extensions terminate in a wooden block. The mechanism is activated by pulling this end piece away from the base or pushing it towards the base. The transition from one stable state to the other is shown in Figure 13.

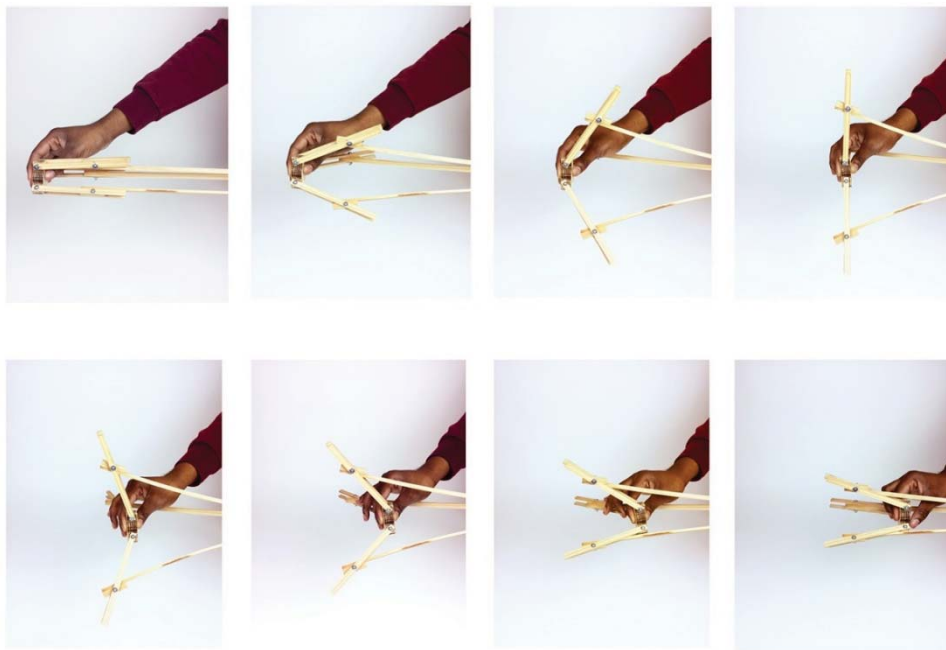

Figure 13 . Actuation of the prototype.





Figure 14. Physical prototype of a bistable mechanism using flexible wood strips to act as springs.

## Concepts for Application for Lightweight Structures

In a world that is becoming increasingly more crowded, and in which globalization makes more places accessible to more people, making one place useful to a larger variety of people with different needs becomes increasingly valuable. The growing population also places a huge demand on a limited supply of natural resources. Instead of relying on new construction to meet the needs of the growing population, can we reduce our consumption of resources by making each building useful for multiple functions? How can we use transformable architecture to achieve this end?

The contextual background provided by the evaluation of reference projects, combined with the feedback gathered from fabricating and experimenting with the physical model, inspired concepts for application of the bistable mechanism into architectural elements. We explored two conceptual applications through digital modelling. The concept models assume that the bistable mechanisms actuate movement of lightweight structural systems. Each mechanism has 3 possible lengths, as shown in Figure 15. In our concept designs we assumed that three mechanisms were connected in series to create a module, and these modules could achieve variable lengths based on the stable state that each of the constituent mechanisms is in.

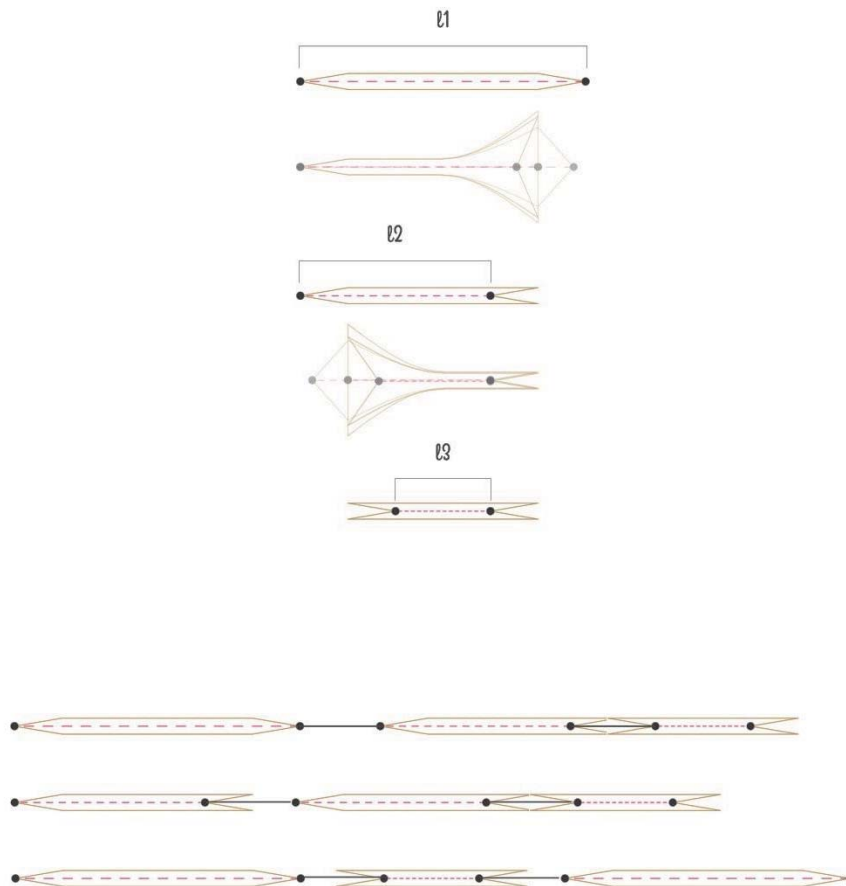

Figure 15. The three possible lengths of the prototype mechanism (above); Variations on modules consisting of 3 prototype mechanisms (below).

It should be noted that when these mechanisms are connected in series, they should be linked in such a manner that enables them to change length independently of one another. In other words, the change in length of one mechanism does not apply an activation force to adjacent mechanisms, but rather just changes the relative position of the adjacent mechanisms. This will prevent accumulation of resistance to the impulse force applied to actuate the system. The diagram in Figure 16 demonstrates a system in which the mechanisms are linked in series such that the force exerted by “popping” the end(s) of one mechanism causes a translation of the entire system.

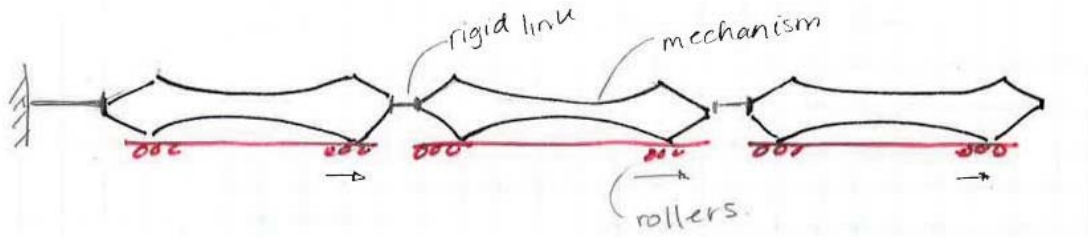
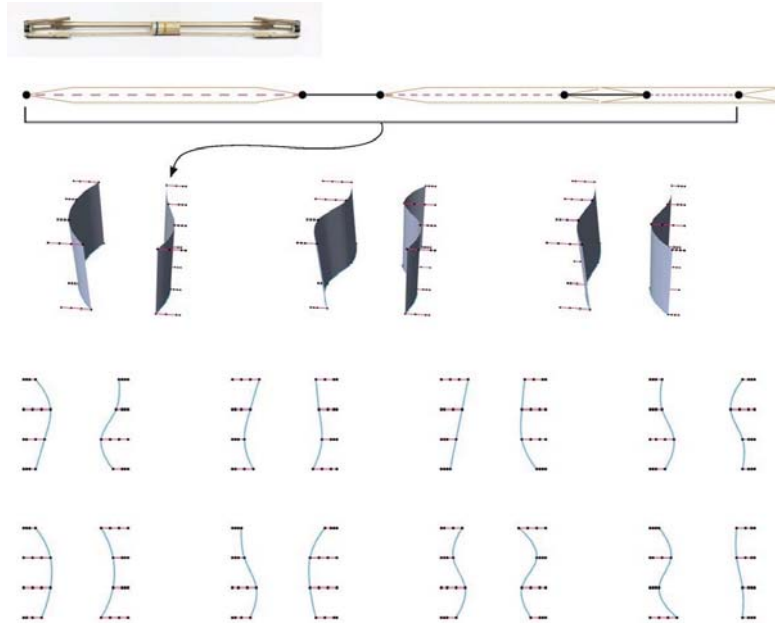

Figure 16. Schematic representation of a linkage system to prevent accumulation of resistance during actuation of the module.

The first application is a flexible wall system. The concept proposes a series of modules that are connected to a flexible wall (potentially fabric or a lightweight hinged frame) at its base and its top. By popping the mechanisms in each module into different lengths, the curvature of the wall can be changed. When two or more of these walls are used to define a space, the ability of the wall to change shape enables the user to create a variety of different spatial configurations, as shown in Figure 17. This system may be useful for changing room arrangements to accommodate changes in program or for influencing circulation through a space, or the change may be simply for experiential effect. It is assumed that this system would be able to be manually controlled by the user.



*Figure 17. Potential application of the prototype mechanism to transform the shape of a wall. Grasshopper for Rhino was used to build a parametric model of the wall system and generate a series of wall variations based on random combinations of three prototype models at each wall control point.*

The second application is a flexible roof or ceiling system, which expands upon the wall system by using a network of modules arranged in a grid to control the surface curvature of a lightweight ceiling or roof. By varying the lengths of the modules in the grid, variations in the surface geometry can be achieved as seen in Figure 18. This has potential applications for controlling room acoustics, or indoor climate. In this concept it is assumed that the actuation of the modules would be computer-controlled.

Future research will include experimentation with different materials and application of the mechanism to architectural prototypes at various scales.

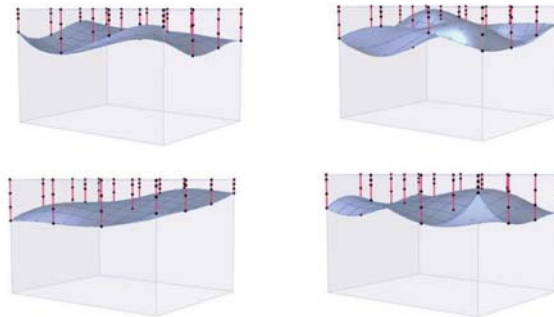

*Figure 18. Potential application of the prototype mechanism to control roof/ceiling surface geometry. Grasshopper for Rhino was used to build a parametric model of the ceiling surface and generate a series of surface geometries based on random combinations of three prototype models at each surface control point.*



## Conclusions

An article entitled "The way we'll live," published in 1999 in the United States recognized that our increasingly more dynamic lifestyles require a more flexible way of living, and called for an architecture that can adapt to our changing needs. If we assume that the function of a space is defined by situations and not just a static moment, we can conclude that time is an essential factor in the creation of "place." Transformable architecture embraces this sense of time because it is dynamic in nature and therefore enables the creation of situations. In other words, the function of a place is not just a snapshot in time, but rather a series of happenings, and one can argue that transformable architecture, "as an equally malleable extension of who we are and how we live," can accommodate the evolution of situations.

## References

- De Marco Werner, Carolina. 2013. "Transformable and Transportable Architecture: Analysis of Buildings Components and Strategies for Project Design." Thesis, Universidad Politecnica Cataluna.
- Kronenburg, Robert. 2007. *Flexible*. London: Laurence King.
- Lee, Joshua David. 2012. "Adaptable, Kinetic, Responsive, and Transformable Architecture: An Alternative Approach to Sustainable Design." Master's Thesis, The University of Texas at Austin.
- Rosenberg, Daniel. 2010. "Indeterminate Architecture: Scissor Pair Transformable Structures." *Footprint*, 19-39. <http://www.footprintjournal.org>.





# Musical Morphogenesis

## A Self-Organizing System

Maria João de Oliveira<sup>1</sup>, João Pedro Sousa<sup>2</sup>, Vasco Craveiro Costa<sup>3</sup>, Sancho M. Oliveira<sup>4</sup>, Ana Mena<sup>5</sup>.

<sup>1</sup>Instituto Universitário de Lisboa (ISCTE-IUL), DINÂMIA'CET-IUL, Lisboa, Portugal,

<sup>2</sup>Instituto Universitário de Lisboa (ISCTE-IUL), VFABLAB-IUL, Lisboa, Portugal,

<sup>3,4</sup> Department of Information Sciences and Technologies, ISCTE-IUL/University Institute of Lisbon, Lisbon,

<sup>5</sup> Instituto Gulbenkian de Ciência, Oeiras, Portugal.

<sup>1</sup>mjoao.oliveira@iscte.pt; <sup>2</sup>jsousaarq@gmail.com; <sup>3</sup>Vasco\_Craveiro\_Costa@iscte.pt;

<sup>4</sup>Sancho.oliveira@iscte.pt; <sup>5</sup>anamena@igc.gulbenkian.pt

**Abstract.** We feel and seize the built environment through senses and body's interactive movement. During this process, our mind and physical status is processing solutions and methods of integration and adaptation that enable us to integrate and live with and in our surrounding environment.

In this paper, we provide an overview on "Musical Morphogenesis" interactive installation, which interacts through colour, light, movement and sound with the environment and its inhabitants. In addition, we intend to take visitors in a sensorial journey to explore the dynamic action of a network of genes during the development of an organism. Finding its roots in the Autopoiesis' theory (Maturana & Varela 1980), "Musical Morphogenesis" acts and interacts as a self-producing system. This installation results from a multidisciplinary collaboration of six main scientific disciplines: complex systems, computational biology, music, architecture, robotics, and science communication. During the design and implementation of the installation's components, the specificities of each discipline had to be taken into consideration, resulting in an extremely challenging project.

**Keywords.** Biomimicry; Morphogenesis; kinetic; nature-based-design.

## Introduction

The concept of self-organizing systems was first introduced by Ashby in 1947. Self-Organizing Systems refer to a class of systems that are able to change their internal structure and function in response to external stimuli. (Ross Ashby 2004). By self-organization it is understood that the system's elements are able to manipulate or organize other elements of the same system, in a way that stabilizes either the structure or the function of the whole against external fluctuations (Banzhaf 2002).

## Project Scope

In the last decade, architecture brought to its agenda questions on performance and interaction as key factors of the design process (Hensel and Menges 2008). Current technologies linked to design and architecture such as digital fabrication and manufacturing resources enable architecture to become more responsive and performative. This achievement is made through the use of



technologies such as Non Uniform Rational Basis Spline (NURBS) programming, visual programming languages, Computer numerical control (CNC), laser cutting, 3D printing and scanning, among others fabrication processes and techniques. Over the past years, several contributions were made in the living systems study, and regarding the relationship between their components, co-existence and complexity (Hensel, Menges and Weinstock 2010). The Autopoiesis Theory (Maturana and Varela 1971) seems to contain the necessary knowledge to enable the creation of individual self-producing systems.

## Related Work

In 1978, Peter Pearce in his *Structure in Nature Is a Strategy for Design* book presented the concept of Minimum Inventory - Maximum Diversity. In general lines this concept can be summarized as: a minimum inventory/maximum diversity system is a kit of modular parts and rules of assembly. In a successful system, the rules of assemblage and physical components work as natural organisms where rules grow from modules and modules grow from rules, creating a relationship of interdependency and consequence.

Based on Füller's experiences on geodesic arrangement of hexagons and pentagons, Grimshaw developed the Eden Project, a horticultural building structure. The project finds its basis in clusters of bubbles for the general form and dragonflies' wings to solve the structural challenge. The diameter of the bubbles could be varied to provide the growing heights required in the different parts of the building, and a necklace line that could be arranged to suit the approximate topography of the site. Through these strategies, architects were able to minimize the amount of the required ground shaping and allow for the solar orientation of the building to be optimized. The result is one of the lightest structures ever created and a building that is largely self-heated making use of passive solar design principles.

In 2007, Philip Beesley presents at the Musée Des Beaux-Arts, in Montreal (Québec), the Hylozoic Soil installation. Custom-manufactured components were produced making use of parametric design and digital fabrication. Machine intelligence was embedded within a network of micro-controllers that coordinated groups of proximity sensors and kinetic actuators. Arrays of capacitive-sensing whiskers and shape-memory alloy actuators were used to create a diffuse peristaltic pumping, which pulled air and organic matter through the occupied space. The installation offered layers of intriguing individual and group behaviors. Building upon simple motions embedded within individual elements, turbulent wave-like reactions are produced. Using tendrils, fronds and bladders to lure the visitors into its seemingly fragile web of laser-cut acrylic matrices, this work was able to blur the distinction between organism and environment. Operating at the intersections of architecture, design, engineering, and art, Hylozoic Soil is a visceral experience of exploring the nuanced relationship between the biological and the artificial.

In order to design a periodic structure for a coffee shop, VFABLAB-IUL (ISCTE-IUL, Lisbon) develop the Discursive wall – a Living System in 2012. Using digital fabrication processes to develop and design an acoustical cork panel, the goal was to create a wall responsive to human interaction. The fundamental hypothesis supporting the system was the design of an architectural living system constantly being designed and re-designed through its inhabitants. Inspired in the behavior of an *Arabidopsis thaliana* flower, the target was to develop a 3m x 5m wall, that would physically respond to movement, interacting with the temporary space, establishing a direct dialog with the inhabitants, constantly reshaping their perception, minimizing acoustical problems of the space. (de Oliveira et al. 2012). (Figure1).



Figure 1. From left to right: Montreal Biosphere - Buckminster Fuller [1]; The Eden Rainforest Lookout, by The Grimshaw Architects [2]; The Hylozoic Soil installation, Montreal, by Philip Beesley [3]; Living System - a Discursive Wall, by VFABLAB-IUL [4].

## Goal

The main goal of this project was the development of an itinerant installation with which the visitors could interact and learn. It models an *Arabidopsis thaliana* flower at a human scale, and its development should obey to the mathematical model of the gene-regulatory network responsible for its growth. The installation is composed of (i) a robotic model that mimics a flower, and whose kinetics reflects the temporal progression of the genetic network as it controls the flower growth development, and (ii) an interface for the visitors to interact with the installation. Through the interface, the visitors are able to select which of the flower's genes are expressed, steering the network towards the formation of different organs - petals, sepals, carpel or stamens. Finally, in order to facilitate the comprehension of the network, each gene is associated to a specific sound (Figure 2).

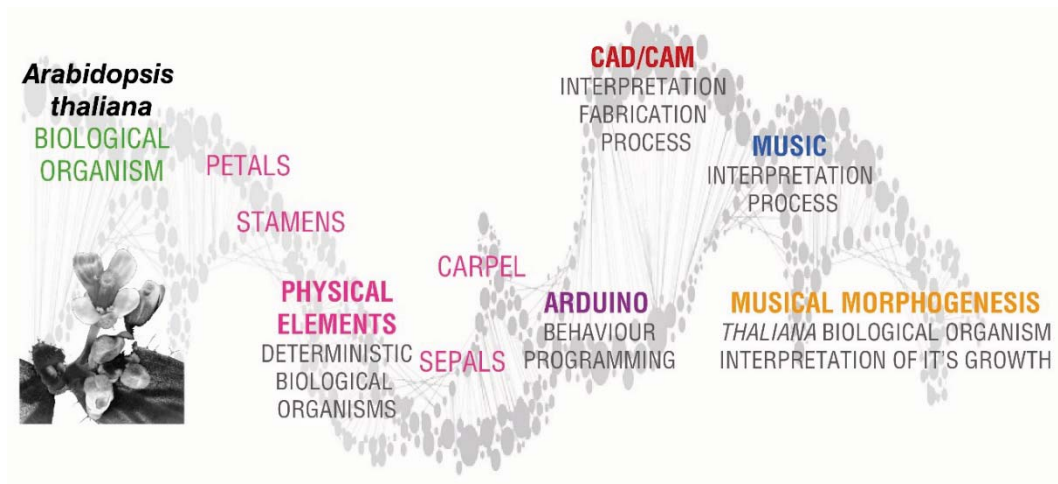

Figure 2. Strategic diagram of Musical Morphogenesis composition.

## Methodology

Projects combining science and art have the potential to address difficult scientific messages to the general public, resulting in enriching experiences to the visitors. But how easy is it to create a multidisciplinary project with a strong scientific message? In the development of this project, the following methodology encompassing five stages was followed:



### **Stage one – Study of *Arabidopsis thaliana***

The first stage of this project privileged the research and understanding of the chosen living organism, the *Arabidopsis thaliana* flower. This is an important step where the essential genes are identified and their functions and relevance on the growth process are determined. The mathematical model proposed by the team members showed that just 15 genes are sufficient to lead to the development of all organs of the flower. Synthesizing the flower's genetic information, it was possible to describe its regular growth, as well as the influence of possible disturbances in it. The project was (re)draw with all the elements of the multidisciplinary team (Architects, Computation Biologists, Science Communicator, Computer Engineers and a Musician), in way that each member was able to interpret and input several data from its own field of knowledge (architecture, engineer, music, computational biology and science communication).

Every living system is a self-organizing system. Every living organism has a predetermined route, composed of genes and proteins, draw for its well growth, but biological disturbances could force the system to readjust this route. In such cases, the organism has to adapt its internal organizational growth and find new hierarchies, routes, eventually culminating in different physical expressions, in order to react and compensate the external disturbances.

Computers are based on a central processing unit that execute a set of instructions programmed by a user. They are also able to read and collect information from several devices such as memory banks keyboards, mice, and even our voice, information that is used during instruction's execution. What takes place in nature is similar to a computer working process. Cells read the information from genetic memory banks (which in this case corresponds to the DNA) as well as receives signals from the environment and from their own state. With the collection of all this information, cells are then able to produce different kinds of proteins. Unlike computers which typically have a central processor, in cells, information processing and computation of required tasks is done in a distributed way through networks of genes, proteins and other biochemical components.

In nature, when an organism start developing a tissue or organ, several genes and proteins start to interact. All cells of an organism contain the same set of genes, but these can be in an active or in an inactive state, conducting to the production or not of proteins. The configuration pattern of active and inactive genes determines the type of tissue or organ that is formed. This is Musical Morphogenesis main scientific message.

To simplify the scientific message to be apprehended by the visitors, the software that served as interface with the installation was programmed to reproduce the most common pattern of the genetic network, which leads to the formation of petals. However, the final result of the interaction with the installation could be other than the physical expression of petals. The visitor could steer the network, activating and de-activating different genes, which eventually conducts to the expression of another organ other than the petals (sepals, stamen or carpel).

*Arabidopsis thaliana* mathematical model is composed of fifteen genes, which can be either active or inactive. The specific configuration of active and inactive genes at each instant defines a state. The gene-regulatory network rules define which genes are active or inactive on the next time instant. This new configuration represents the next state that the network has reached. The sequences of states along time corresponds to a paths. Each path leads to a final state , an attractor, that represents the expression of the organ. The network rules specify several paths that end in different attractor states that will lead to the expression of a different organ. When at a given instant an interference is made on a state, by flipping a gene from ON to OFF or from OFF to ON, there is a change on the current state. This new may belong to a different path that will lead to the expression of a different organ.

## Stage Two – Design, scale, structure and material

The design of a self-supporting installation with sufficient mechanical resistance to be assembled and disassembled by only three to four people was one of the challenges in Musical Morphogenesis project. The first step of the design process consisted in the replication of *Arabidopsis thaliana*'s shape. Following stage one, the design team had to project a self-supporting installation that served as base to the four essential flower's organs – sepals, petals, carpel and stamens. The installation had to be prepared to allow movements from the different organs. The decision on the material to be used in the construction of the installation main structure and key components presented as an important milestone in the design process., The chosen material should aggregate a set of characteristics namely durability, resistance, and friendly cutting properties. Achieving all these requirements, Valchromat [5] was the chosen material. It consists in a type of MDF with the added characteristic of being produced in several different colors, essential for the expressiveness of the model and eliminating the necessity to be painted afterwards.

### *The organs*

Musical Morphogenesis main structure was designed to mimic a flower's button, the initial physical shape of a flower's growth. This structure is composed of eight vertical elements, working as pillars, linked through five horizontal circular elements which contain the entire electronic components as well as the compressed air system. The complex net of electric cables and air tubes were thought and assumed freely in the installation as representation of a living vascular system. The five circular elements are associated to location of the different organs of the flower during its normal development.

To represent the possible genetic transgressions and deviations of the natural growth pattern, minor sizes and misshapen sepals and stamens were fixed at the installation, in a non-natural site-specific location. These elements express the pattern growth deviation of the flower, exhibiting genetic deviations and deformations. The complete amount of organs resulted in twelve petals, eight sepals, eight stamens and one carpel. The petals, the most iconic organ of the flower, assume an imperialistic shape being the longer organ and being represented by the red color. The petals are positioned at the second, third and fourth structural levels. The sepals assumed a shape of 'inverted' petals not only because genetically they have the same initial gene, but also because formally they are the first petals that protect the flower in its button stage. The sepals were represented by the blue color and were positioned at the first and fourth structural levels providing a clear expression of an organ that is being wrongly expressed, in the latter case. Both petals and sepals embrace the vertical pillars and produce an open/close movement driven by compressed air.

The stamens, like in the natural *Arabidopsis thaliana*, rises inside the flower through the shape of very delicate and sleek profile. Long, sleek yellow elements were designed as well as small mechanism that enable it to produce a 45° angle movement. Stamens have an influence in the structure all the way to the fourth level of the installation. The open and close movement of the organs is generated by a compressed air system.

The carpel, the majestic central element of the flower, was represented through a continuous acrylic cylindrical element, assuming its formal and functional difference. It is the only organ that influences the five levels of the installation, and unlike the remaining ones, it contributes to the installation through changes in light colors, instead of movement (Figure 03).



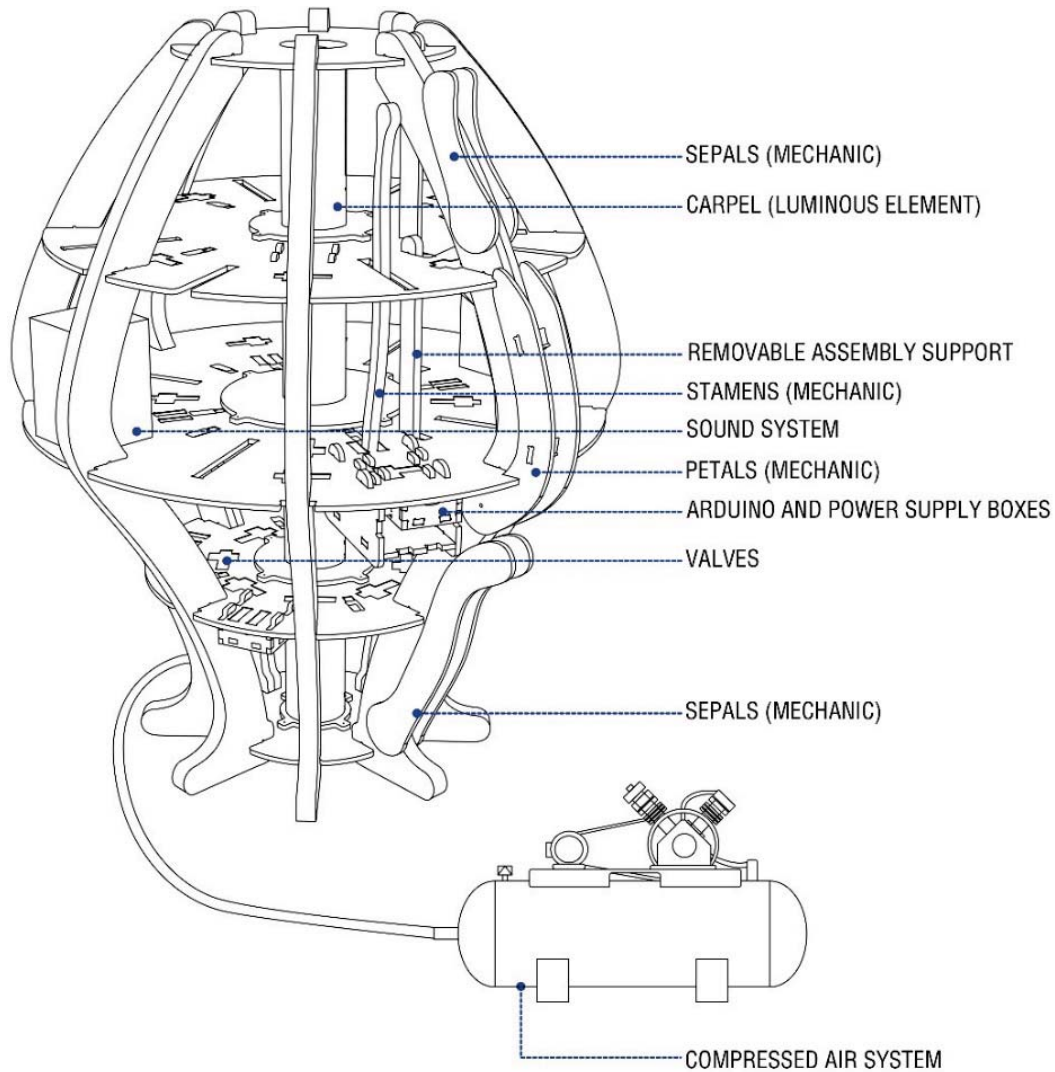

Figure 3. Musical Morphogenesis blocks and components diagram.

### Stage Three: Fabrication and Assemblage

Musical Morphogenesis was thought and conceived to be assembled and disassembled several times (a limited). To achieve this goal, the elements were designed to produce volumetric impact using bi-dimensional strategies, and the entire installation had no fixed elements. This strategy also enabled us to optimize the use of material and the fabrication time. All the joineries, from the button structure to the different elements were made to fit each other through male/female fittings to form a three-dimensional object. Some metallic parts were also used, such as screwed rods - used to fix organ elements to the main structure, or screws - to fix the valves to the circular levels, but all the installation can be disassembled in twenty-five separated sections.

All the elements were organized in 1850 mm X 2500 mm colored Valchromat boards, with 16 mm and 30 mm in thickness, and in black, yellow, blue and red colors. All the structure was conceived in black boards with 30 mm thickness for the vertical pillars, and black boards with 16 mm thickness for the horizontal circular elements. The twelve petals were produced in red boards



of 16mm colored Valchromat material, the eight stamens in yellow boards of 30mm and the eight sepals in blue boards of 16mm.

The assembling process starts with the vertical organization of the horizontal circular levels, sustained by removable pillars and the carpel sections that connect and link the structure between levels. The second step is to engage the vertical pillars of the structure, in a total of 8 of them. The petals and the sepals are already assembled in the pillars, reducing the assemblage complexity. There are two different versions of the pillars, accordingly to the organs that are assembled in each of them, in a quantity of 4 pillar of each version. The first pillars' version is composed of both sepals and petals and the second version ones only have petals assembled. The two versions are alternately installed around the levels. The third step consists in securing the Stamens to the horizontal elements and connect them to the corresponding compressed air cylinders. The fourth step comprises several tasks: the connection of all electric cables (both control, power and sound), and the installation of the compressed air tubes. The electromagnetic valves that control the air flow to the cylinders are already installed in both sides of the different levels, along with the necessary control electronic hardware. In this step, there is the necessity to install the plumbing that provides compressed air to the valves, and the one that conducts the air from the valves to the cylinders, which actuate the different kinetic parts. The sound speakers also come separated from the levels and are installed in this step. The final step consists in the calibration of both the sound level and the opening and close time of the different elements, making use of a calibration program. In parallel with these steps, the interface both and unit is also assembled. It contains the main computer, a touch screen and a sound mixer, along with a subwoofer.

#### **Stage Four: Choreographing through motion**

The behavior of the Musical Morphogenesis is expressed through motion, light and music and is controlled accordingly to *Arabidopsis thaliana*'s mathematical model of the gene-regulatory network. The model is executed in the interface's application, and at each step of the model, a combination of motion, light and music is defined. This combination is then sent from the computer to a control unit installed in the third level of the structure, which receives the information related to the different elements state (open or closed) and to the carpel's color. The control unit is composed of an Arduino Mega stacked with a custom made printed circuit board (PCB). To control the carpel light, which is composed of 5 individual rows of LEDs per section, in a total of 20 rows, a custom-made control circuit based on TLC5940's integrated circuit is used.[6] The intensity of the music and the range of motion is inversely proportional to the distance in the path to the final state. For each different path, leading to the expression of a different organ, a specific motion pattern was design and a specific musical theme was written. Each theme is composed of fifteen different sub-themes each corresponding to a gene. The active sub-themes at given moment are controlled by the active genes. Once the final state is reached an ending sequence is executed and a new interaction with Musical Morphogenesis starts. (Figure 4).

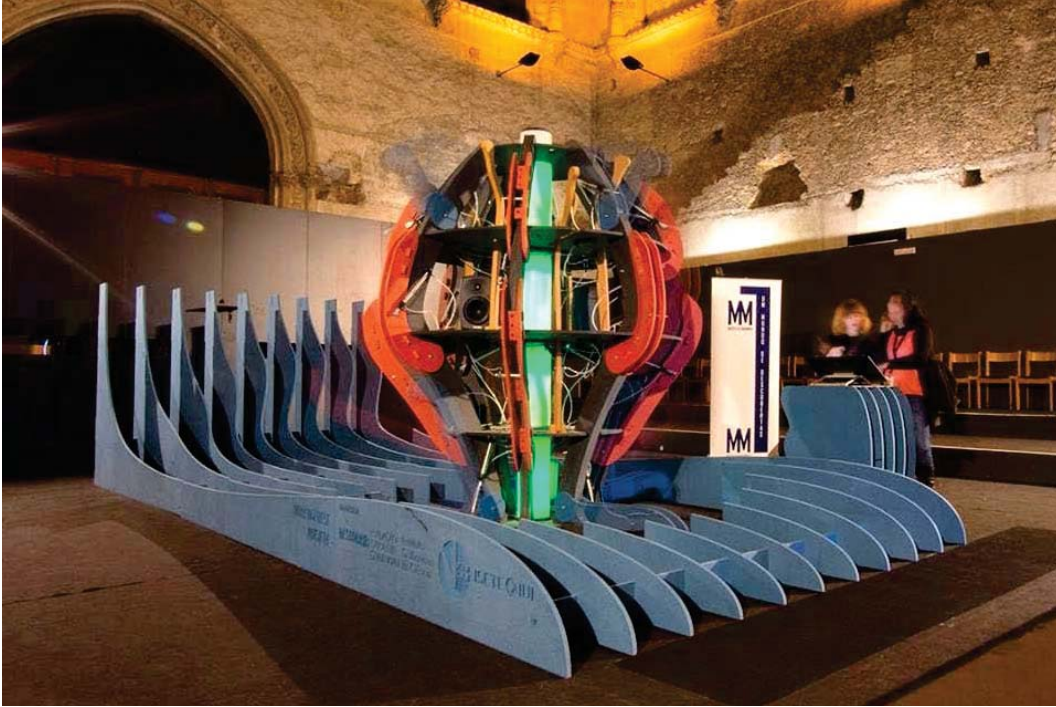

Figure 4. Musical Morphogenesis in exhibition at Jerónimos Monastery, Belém, Lisbon, 2016.  
 (Photography by Vasco Costa)

### Stage Five: Human/installation Interface

The goal is to essay and visually experience the growth process of the flower and its organs. The human role is to set the state by defining the configuration of the 15 genes, during the process of growth. By defining the state the user is changing the path and consequently the final state (gene or protein) that will influence and determine the growth of one specific element and, as consequence the entire development of the flower. During the growth progression, fifteen genes and proteins interact with each other, enabling the evolution and change of the development path. In addition to the activation state determined by the mathematical model that runs this installation, the user may turn on or off one or more genes at different times of the interaction. When the regulatory genetic network of *Arabidopsis thaliana* finds a potential deviation from the path, the visitor may try to find the genetic path that will lead to the development of a desired organ, looking for the attractors underlying it. For instance, if the visitor wants to force the growth of the petals, s/he has to select proteins or genes that are closer, or that could improve the probabilities of development of that organ.

Physically, the Musical Morphogenesis interface is composed of a touchscreen application, that runs the gene regulatory network's mathematical model. Visually, the interface exhibits a gene and a protein 'keyboard' containing the live combination that is running at the moment of the flower's growth. Every time there is a chance for an external intervention, the possible genes start to blimp in the monitor. This is the moment in which the visitors are called to interact. The 'pause' state is also expressed in the installation: it starts to move unnaturally, with a confusing combination of colors and sound.

The application has also several elements to guide the visitor through the interaction with the installation. (Figure 5) The visitor can interfere with the genetic program by pressing a panel of fifteen buttons that represents the fifteen genes, located at the bottom of the screen (the gene and

protein 'keyboard'). The central panel shows the organ that is being formed by the present configuration of the genetic network. Each organ is represented by an icon with similar color to its counterpart in the installation. On the top, there is a timeline that shows the historical of the visitor's interactions, i.e. which organs were closer to formation at a certain moment of development and internal clock of the software. The visitor may also choose to pause the development process or mute the sound, as well as to further explore the sound associated to each gene. A tutorial with the biological background underlying this installation was also created, in the format of an animation accessible through the interface.

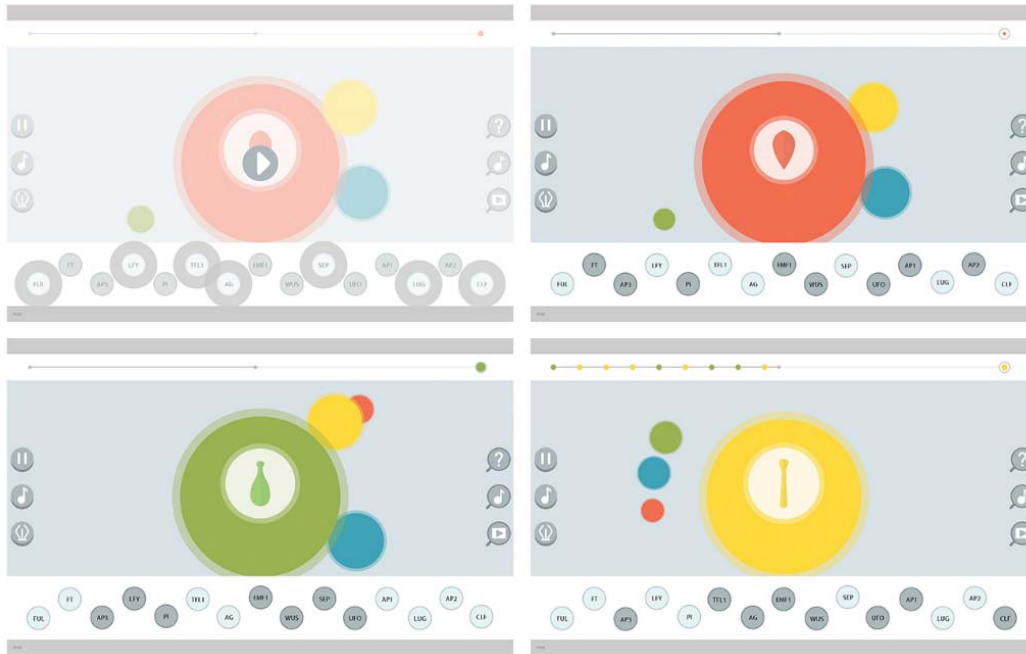

Figure 5. Musical Morphogenesis interface application screen shoots.

## Conclusions

'Musical Morphogenesis' is an interactive installation that translates into sound and movement the dynamics of a flower's development process. The development of an organism, or even a tissue or organ, is controlled by a system of genes and proteins. The behavior of the system is collective, in a way that it is not predictable from the individual behavior of each gene. The logic of this genetic control system can also be decoupled from the original organism, as a model. It can then be used not only in other organisms, but also to create message transmitting installations similar to the one exposed in here.

In this installation, we can visualize and interfere with the dynamics of the genetic regulation process by turning activating and inactivating genes and proteins. Doing so, there is a likelihood of developing a mutant type organism instead of a wild type strain.

During the process of creation, design and assembly, many issues appeared and conducted us to redesign the installation for better convey the scientific message underlying Musical Morphogenesis. This installation was exhibited in six different venues in Lisbon metropolitan area, reaching over 2 500 visitors. The feedback received from the visitors that interacted with the installation was overall positive, with different visitors highlighting different aspects of the



installation, from its grand appearance and engineer complexity, to the scientific message and the music. (Figure 6).

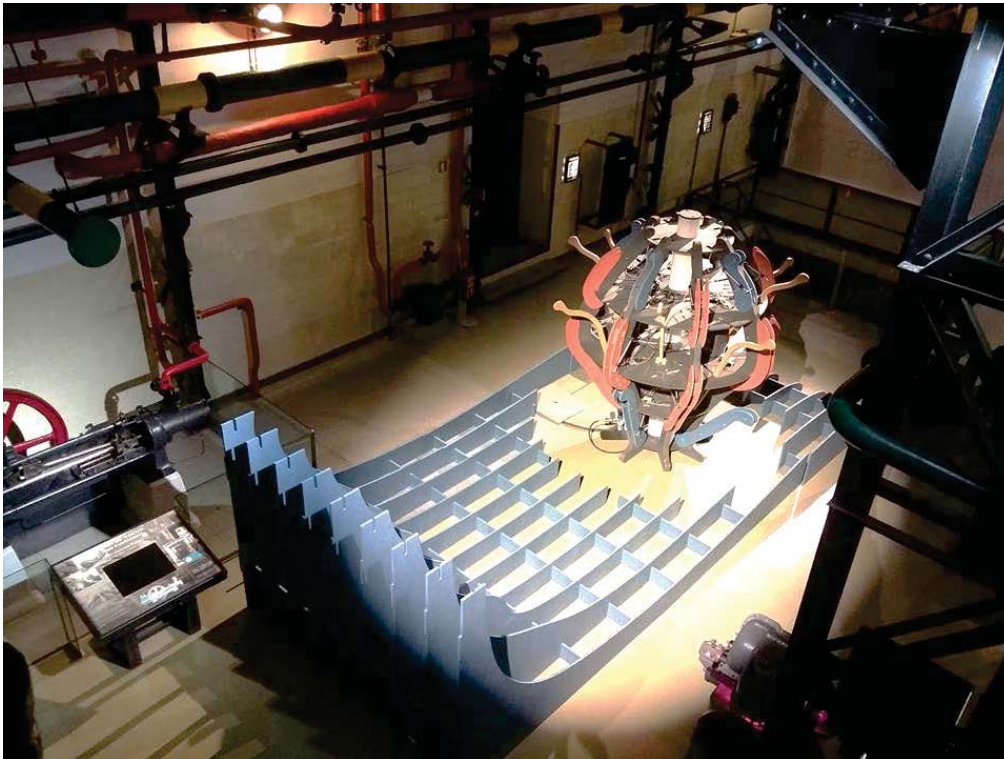

Figure 6. *Musical Morphogenesis* in exhibition at MAAT MUSEUM, Lisbon, 2017 (Photography by Vasco Costa).

## Acknowledgements

Musical Morphogenesis multimedia installation was conceived by Ana Mena (Science Communicator), Alexandra Paio (Architect), João Pedro Sousa (Architect), Maria de Assis Swinnerton (Director of the Gulbenkian Education Program for Culture and Science), Luís Rocha (Computational Biologist), Manuel Marques-Pita (Computational Biologist), Maria João de Oliveira (Architect), Sancho Oliveira (Computer Engineer), Simão Costa (Musician) and Vasco Craveiro Costa (Computer Engineer). The design of the interface was done by Rui Madeira. The assemblage of the project was in several moments assisted by Elisabetta Corvino, Diego Novo, Rúben Viegas and Susana Neves.

The Calouste Gulbenkian Foundation, Instituto Gulbenkian de Ciência and the Vitruvius FabLab-ISCTE-IUL were the institutions responsible for the production of Musical Morphogenesis, under the coordination of Maria de Assis Swinnerton.

The team would like to thank to Valchromat – Investwood for all the support.



## References

Banzhaf, W., *Self-organizing Systems*. Encyclopedia of Physical Science and Technology, pp.589–598, 2002.

De Oliveira, M.J., Paio, A. & Rato, V.M., "Fabricating a Living System - Uploading the Design Process into Material Performance", *ICONARCH I*, Konya, Turkey, pp. 294–302, 2012.

Hensel, M., Menges, A., "Versatility and Vicissitude: Performance in Morpho-Ecological Design", *Architectural Design* Vol. 78 No. 2, Wiley Academy, London, 2008.

Hensel, M., Menges, A., Weinstock, M., *Emergent Technologies and Design. Towards a biological paradigm for architecture*. USA and Canada; Routledge, 2010.

Kolarevic, B., Klinger, K., *Manufacturing Material effects. Rethinking Design and Making in Architecture*. USA and Canada; Routledge, 2008.

Maturana, H., and Varela, F., *Autopoiesis and Cognition. The Realization of the Living*. Boston Studies in the Philosophy of Science, v.42, Boston; D. Reidel Publishing Co., 1980.

Ross Ashby, W., "Principles of the self-organizing system", *Principles of Self-Organization: Transactions of the University of Illinois Symposium E:CO Special Double Issue* Vol. 6 Nos. 1-2 2004 pp. 102-126, 2004.

[1] <http://www.archdaily.com/572135/ad-classics-montreal-biosphere-buckminster-fuller> (last visited 05.02.2017)

[2] [http://www.thethinkinghandstudio.com/mies\\_portfolio/edenrainforestlookout/](http://www.thethinkinghandstudio.com/mies_portfolio/edenrainforestlookout/) (last visited 05.02.2017)

[3] <http://ounae.com/hylozoic-soil-bosque-artificial-interactivo/>(last visited 05.02.2017)

[4] <https://www.revarqa.com/uploads/docs/dossier/arqa-106-Dossier-2.pdf> (last visited 05.02.2017)

[5] <http://valchromat.pt/> (last visited 05.02.2017)

[6] <http://www.ti.com/lit/ds/symlink/tlc5940.pdf> (last visited 05.02.2017)





SESSION 04  
METABOLIC ARCHITECTURE: GENETICS, DIGITAL  
MORPHOLOGY, TURING, & AI  
Dennis L. Dollens & Alberto T. Estévez

*Digital Fabrication in Education: Inside An Emerging Design Program*  
Louay Youssef



*Re-morphing the Amorphous - Creating New Urban Substance*  
Yannis Zavoleas



*A Study on the Materialisation and Formation of Mycelium in  
a Fabric Formwork*  
Gulay Elbasdi, Sema Alacam



*Growth as the Morphological Generator of Biological Identity*  
Ricardo Massena Gago



*Heliotropic Nature's*  
Mary Polites, Maddalena Belle, Marida Maiorino, Raquel Paramo, Brandon DiFalco,  
Carmo Cardoso



*Design as an adaptive time-scape*  
Susannah Dickinson



*The built environment as an extension of human biology*  
Alexander, Damásio, Bratton  
Diana Soeiro



## Metabolic Architecture: Genetics, Digital Morphology, Turing, & AI

Dennis L Dollens, Alberto T. Estévez

**Abstract** • In an age of biofabrication and artificial intelligence, reexamining and updating morphological practices as computational morphology leads to metabolically-oriented adaptive behaviors to underpin biointelligent architectures. By investigating microbes and plants the potential for morphological and genetic hybridization prompts us to equate metabolic architectures to large, intelligent machines. Toward that equation, we mine data from nature and import it to CAD systems — accrediting Alan Turing’s pioneering 1950s bioalgorithmic research. We thus see new potential for genetic sequencing paired with the migration of morphological data from industrial CT scanners or electron scanning microscopes as integral parts of design form-finding. In this endeavor, we experiment with biological intelligence, hybrid genetics, and microscopic morphologies in the realm of CAADRIA 2017’s expressed call for research where: “computer-aided architectural design engages . . . that which cannot, or cannot yet, be readily described or modelled.”

In our research, metabolic buildings are investigated along an environment-technology axis warranting support from biological theory (autopoiesis), genetics, philosophy, and cognitive science. With that support axis we intend architectures to, in Scott Turner’s words, “adaptively modify flows of matter and energy through the environment.” Here then, systems appropriate to metabolic architectures are projected to incorporate life functions from microbes, bacteria, or plants. Critically, metabolic architectures require onboard life support in order to sustain microbial or plant-cell abilities. In this situation, buildings become hybrid organisms required to maintain homeostasis in an environment of morphological forms, genetic performance, and biotechnological communications.

We thereby classify metabolic architectures as intelligent organisms expressed as extended phenotypes following the research of Richard Dawkins, Mike Hansell, and Scott Turner. As a consequence of hybridity — living agent + machinic infrastructure — architecture may be contemplated and programmed as intelligent and biochemically responsive to industrial and urban toxins. In this extended phenotypic milieu, architects join scientists, engineers, and theorists to participate in global climate bioremediation by designing from playbook of animate, inanimate, and machinic nature for metabolic architectures.

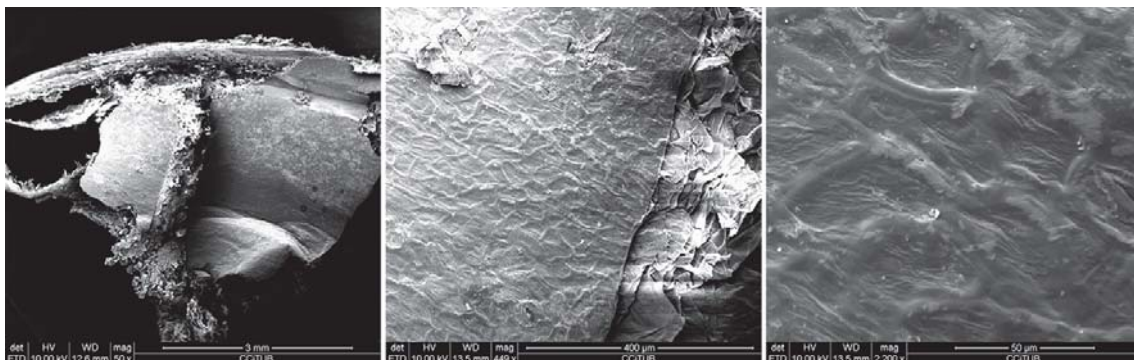

Figure 1. Scanning Electron Microscope (SEM) images. 2016. *Datura ferox* seedpod. Left to right: 1. Inner chamber walls 50X; 2. Surface wall patterns 449X; 3. Surface wall patterns 2200X. Estévez/Dollens.

## Introduction: Digital Morphologies

For biointelligent participation in nature, a building's metabolic tasks must underpin living technologies with morphological and physiological infrastructures that support microbial or cellular life (Figure 1). We suggest that a building's intelligence be strictly monitored and modeled on bacteria, plant, or non-human animal life — not on human cognition. We look to the journal, “Artificial Life,” to outline pathways along which living technology will emerge: “based on the powerful core features of life explained and illustrated with examples from artificial life software, reconfigurable and evolvable hardware, autonomously self-reproducing robots, chemical protocells, and hybrid electronic-chemical systems” (Bedau et al. 2010).

In terms of realization, living architecture will likely be assemblages of biorobotic components incorporating living cells, engineered proteins (Service 2016), biosensors, and actuators in order to, for example, synthesize energy, bioremediate pollution, or deploy bioluminescent properties (Estévez 2007). In the July 2016 issue of “Science,” Robert Service described David Baker’s advances in the design and 3D printing of synthetic protein structures potentially appropriate to genetic bioremediation for architectural experimentation: “Complete with a designer protein that enabled the microbes to convert atmospheric carbon dioxide into fuels and chemicals” (Service 2016).

With breakthroughs in science and technology, we contemplate architectural intelligence through a four-part classification involving animals, plants, microbes, and machines. Further, we deploy procedures and equipment that link technology with design to establish generative, digital morphologies to import into CAD systems. As an example, we looked to *Datura ferox* (Figure 4) as an organism of coordinated sensory/response intelligences — nanomachines according to Paul Falkowski (2015, 133-135) — for which we observed morphologies capable of influencing bioarchitectural infrastructures and functions. Here then, digital morphology supports form-finding and biomechanical reactions derived from living specimens pertinent to architectural performance (Baluška and Mancuso 2009; Mancuso and Viola 2015).



Figure 2. Genetic Barcelona Project: urban/domestic real bioluminescence. 2003-ongoing. From left to right: 1. Simulated bioluminescent tree; 2. Bioluminescent trees lighting Gaudi's Casa Mila; 3. Comparison between a normal and a real genetically transformed (live) lemon-tree leaves. Alberto T. Estévez.



We propose theory and processes through which the knowledge of scientific equipment for design visualization will motivate designers to sample data, performance, and imagery from organisms and nature's structural organizations. Such design-by-research supports evolving morphological forms as substrates or components for living or AI-guided intelligence. For this research, procedures began in two phases. First, in 2003 with Estévez's (2007, 2015) sequencing and gene-transfers investigating medusas, lemon trees, bacteria, and flowers for bioluminescent performance (Figure 2). Estévez's research points out that bioluminescence is linked to metabolic intelligence, sensing, and signaling demonstrated, for instance, by fireflies to attract mates, or by cuttlefish to camouflage themselves from predators. Secondly, research was initiated in 2005 by Dollens (2015) for digital-botanic towers whose biointelligence is embedded in plant algorithms and morphological shape-shifting forms (Figure 3).

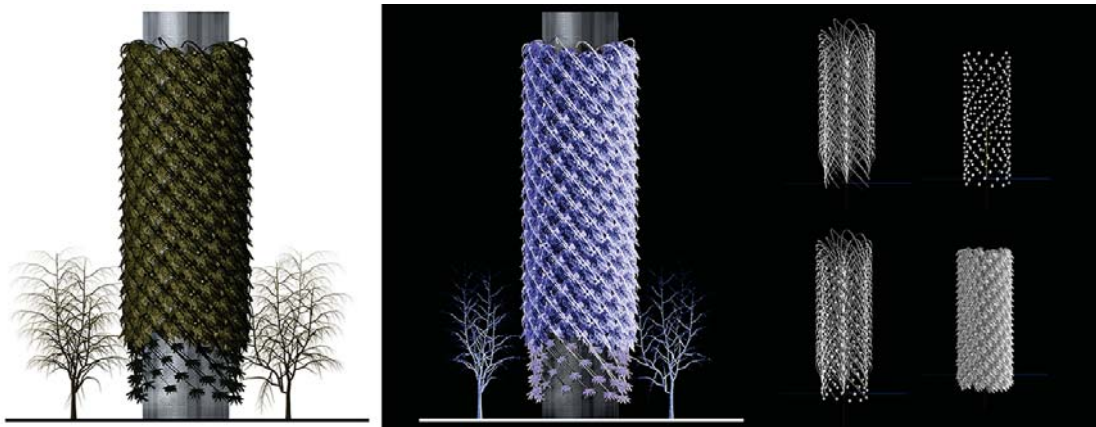

*Figure 3. BioTower. 2005-ongoing. Exoskeleton simulated from plant/tree algorithms to support microbial intelligent performance. Dennis Dollens.*

Once the translation of biological research involving attribute-to-machine performance is identified — microbial sensing, digesting, illuminating, or signaling — design strategies for application can result; for example, Estévez's biolamps (2007-2010) or his bioluminescent lemon trees. From there, we can theoretically link concepts of sensory and bioperformative architectures as consistent with genetic engineering via human-extended phenotypes (Dawkins 1982; Turner 2000). To this end, and in accordance with Scott Turner's theory, we posit architecture where: "Animal-built structures [human constructions included] come into the picture because these are the agents whereby organisms adaptively modify flows of matter and energy through the environment" (Turner 2000, 212).

By decoding biological data embedded in CT scans and images from scanning electron microscopes (SEM), we also emphasize that, in the long course of interconnectivity, a new ecotone of science, technology, and architecture will nurture rigorous architectural engagement with environmental problems from which we expect to gain admission to microscopic and molecular nature. In this scenario, we are likely looking ahead to collaborations with scientists and engineers to develop nanomachines and biochemical agents that thrive within architectural frameworks capable of supporting multicellular life. As Falkowski writes in "Life's Engines:" "In even the simplest organisms, the chemical constituents are organized into microscopic machines that give rise to metabolic processes and allow the cell to replicate. . . . For want of a simple term, I call these . . . cells life's nanomachines" (Falkowski 2015, 20 and 47).



If we consider microbial life as nanomachines inhabiting architectures, morphological research reveals forms and physiology for experimental buildings capable of skeletal movement, breathing, branching, bioluminescence, communication, and shape-shifting — all dependent on life's electrical gradients. As "Life's Engines" emphasizes: "all organisms must maintain an electrical gradient across their cell membranes. Among other things, electrical gradients are essential for transporting nutrients into cells and for transporting waste products out" (Falkowski 2015 60). Consequently, implications from Montebelli et al. (2013 301) might be applied to metabolic architectures: "a biomechatronic hybrid endowed with a simple artificial metabolic system . . . [where an] on-board living bacterial population processes biomass, providing the [building] with the electrical energy needed for sensing and action. . . . [with] implications that might be relevant to the development of a sound cognitive living technology, that is, engineered systems whose power specifically derives from core properties of the living system."

## From Alan Turing to Can Buildings Think?

Analyzed from nature and culture, biointelligent architectures may be theorized as intelligent machines and tested following procedures first outlined for computers and algorithmic programming. To bolster this hypothesis, we point to Alan Turing's 1950-1954 computational-botanic simulations framed by his reaction/diffusion algorithms and voiced by his provocative question, "Can machines think?" (1951). We repurpose his question for architecture as "can buildings think?" (Dollens 2015) and support our analogy with this two-part premise: 1), While life/intelligence is not inherent to all matter, matter is inherent to all living, intelligent, and machinic systems. And, 2), Operations between matter, life, and intelligence propel investigatory prospects of living/intelligent buildings in equal measure to those of Turing universal machines (computers/AI).

Toward an unfolding dialogue, we read Turing's plant drawings, simulations, and words as prophetic. Between 1949 and 1954 he translated observations from plants and radiolaria into computational biosimulations in order to extrapolate algorithmic functions for computer programming (Dollens 2014). Turing (1951. 6). wrote: "If we give the machine a program which results in its doing something interesting which we had not anticipated I should be inclined to say that the machine had originated something" We now recognize such heritage when considering biointelligence and AI for programming and simulations in the development of generative bioarchitectures. That is, scripted computation capable of "doing something" architecturally intelligent, e.g.: collaborating with living biochemical and environmental tasks. Here then, shadows cast by Turing grow large given the performance of intelligent machines and AI recently witnessed in Google's AlphaGo or demonstrated by drones, self-driving automobiles, facial recognition software, and search engines.

Articulating and implementing experimental methods such as those demonstrated by Turing, shows us computational procedures for investigating digital morphology and morphological data for pairing with biomimetic observations and synthetic biology. Digital morphology practices then underpin metabolic architectures when specific biological typologies — e.g. exoskeletons, cocoons, cell walls, leaves, seedpods, etc. — are selected by the architect as subjects holding insight suitable to design solutions. The designer determines research goals to establish types of data to seek from imaging equipment, knowing that an X-ray will deliver different data than an industrial CT scan, and images from light microscopes will open different design realms than scanning electron micrographs.

Thereby, data from in-field, laboratory, and studio observations provides architects with visualizations from nature for expression in design. For example, examining plant membrane assemblages or cellular aggregations (Figure 1 middle) opens research windows to imaging and



scanning equipment for decoding morphology as it reveals orders of form, connections, stacking, packing, transitions, and lamination. Light microscope and digital-scanning technology (CT, MRI, SEM) make visible otherwise unavailable ecological forms and data analytically necessary for generative bioarchitectures. Correspondingly, some metabolic buildings may need to move/react beyond thermal expansion, urban vibrations, or wind shear (in ways organisms do) to respond to challenges of biocellular-energy production and/or pollution eradication. Morphological forms, surfaces, and infrastructural systems therein hold solutions for unpacking metabolic support organization. Results may include buildings whose components sense, fold, bend, track, light, branch, or eat pollution in bioreactive procedures. Surfaces, junctures, veins, circuits, and electromagnetic input/output may then be synchronized with morphologically or genetically supported AI or biointelligence and fabricated into architectural components.

Significantly, with living sensors and biochemical actuators, buildings are projected to react metabolically when interior/exterior systems detect environmental pathogens, energy variations, excessive moisture, seismic shifting, or pervasive contaminants. To those properties, types of sensory-intelligent, biochemical communication, and/or bioluminescent (biopixel) signaling may be cached in non-human memory currently being investigated in plant neurobiology (Baluška and Mancuso 2009).

## Neri Oxman: Reverse Engineering a Cocoon

Technological imaging emphasizes ways to enhance design thinking between professional disciplines by appropriating natural processes via data compilation and machine-to-eye investigations. Simultaneously, project complexity may be organized through the innovative design of experiments. For example, Neri Oxman and her team at MIT attached a tiny rare-earth magnet to the head of a silkworm and then digitally tracked the silkworm building its cocoon. The scan illustrated the physical cocoon as a computational point-cloud that Oxman and team interpreted for programming a 3D model. The scan-data and its subsequent model revealed the Lepidoptera's method of weaving silk-filaments as they emerged from its spinneret. Seen in Oxman's 2015 TedTalk, the ensuing project highlights the role of the cocoon and reveals important morphological and performative aspects of the project.

The scan of the cocoon — a kind of digital reverse engineering — allowed the investigation of a structure whose biomaterial is physically manifested by the silkworm's genetically-guided weaving. The scanning process thus captured data for transmission to designers as digitally iterated (strand-by-strand), caterpillar architecture. Hereafter, we classify both the cocoon and the point cloud as extended phenotypes in the category of beehives or termitaries (Dawkins 1982. Hansell 2005. Turner 2000). The scan-mapped fabrication pathways from animal architectures resulted in Oxman's digital-morphological structure as transferable from human cognition and insight to construction.

In the categorical lenses of genotype, phenotype, and extended phenotype the cocoon is architecture produced genetically by the caterpillar. By contrast, seedpods enact ongoing, biological strategies (Figure 4) that, like a cocoon, provide shelter and space for embryological morphogenesis. However, unlike the the cocoon, seedpods genetically emanate from, and remain, biologically alive, physically connected, and metabolically dependent on the parent plant until the seeds are mature. Seedpods thus perform complex biological and biochemical feats not enacted by cocoons. For example, their architectural infrastructure channels nourishment to the womb-enclosed embryonic seeds — giving an ironic twist to Le Corbusier's "machine for living in."

## Digital Morphologies I: CT Scan

The *Datura ferox* seedpod pictured here exhibits a spectrum of morphological, design-assessable forms and attributes (Figure 4). We introduced it to a 2016 class in the Biodigital Architecture Master Program, at the ESARQ, School of Architecture, UIC Barcelona (Universitat Internacional de Catalunya), after subjecting it to an industrial CT scan. We looked at the pod's morphology in relation to performance and how otherwise hidden spaces and forms were revealed to support complex functions seen in the digital scan. The looking, the comparisons, and the placement of the pod within the realm of digital morphology were critical for determining exterior-to-interior support systems in service to embryological seed growth and thus to understanding interior form, volume, and materialization.

After translating the CT scan to a format that Rhinoceros could import (Figure 5), we reduced its resolution and sectioned it in order to digitally access its continually changing shape. The interior surfaces are defined by seemingly smooth walls partitioned by thin membranes into a four-part chamber (Figure 5, upper left). Yet, only millimeters away, and materially identical, the chamber's exterior-facing walls are morphologically different. The pod's exterior bristles with fortress-like defenses covering its entire surface with sharp, irregular-sized spikes. Students considered the spikes to be phenotypic sentinels they could repurpose for new ventures generating surface typologies (Figure 6) for STL modeling and prototyping.

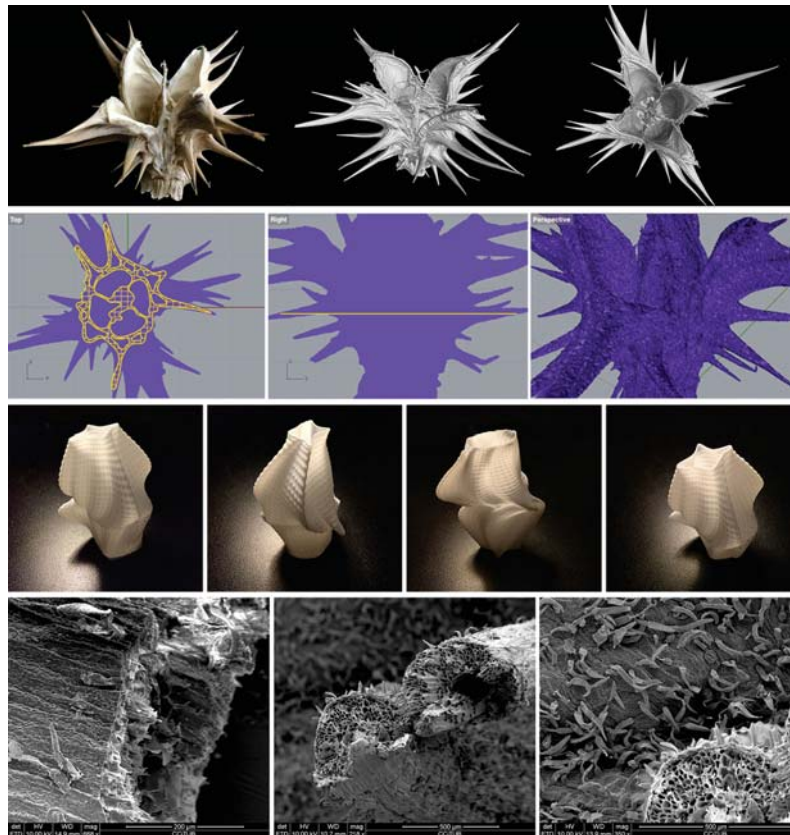

Figure 4. Row 1. Biological and Digital *Datura ferox* seedpod. 2016. From left: A dried biological seedpod indistinguishable from two high-resolution CT scans. Dollens.  
Row 2. *Datura ferox* seedpod. 2016. CT scan imported to Rhino for chamber contours; data used to

generate Figure 6. Dollens.

Row 3. Student Model. 2016. Thin-wall STL model abstracting horizontal sections (Figure 5) of the *Datura ferox*. Mehtap Altug and Stefan Redemeyer.

Row 4. Electron Scanning Microscope images. 2016. *Datura ferox* seedpod. From left to right: 1. Spike edge and surface 668X; 2. Two-part split spike and cellular net 218X; and 3. Spike section 350X. Estévez/Dollens.

As the Latin word *ferox* — savage, warlike — suggests, *Datura* spikes signal danger to predators even while they also enact perimeter defenses. The spikes offer morphological insight for shape-channeling airflow around the pod, while illustrating patterning (shading) of its ellipsoidal body. Reinforcing their spikes' fierceness, *Datura* plants biochemically fortify their aggressive morphology with toxic alkaloids. Accordingly, as designers we encounter morphological and phenotypic defenses (spikes), backed up by biochemical weapons (alkaloid poisons) from which we can reformulate data and imagery to model architectural components and systems.

## Digital Morphologies II: Scanning Electron Microscope

The CT scan enabled a significantly different approach to our design studio's research by linking digital morphology and physiology with data from advanced technological imaging. Still, observed relationships among the seedpods' varying forms — patterned membranes, militant spikes, laminated walls, smooth interiors — raised questions that the CT scan could neither picture or answer; but a scanning electron microscope could.

Suspecting hidden morphologies, we decided to search for micro-surface attributes relevant to generative programming and booked time with a university scanning electron microscope (Figures 1, 4, 6, 7). During the SEM session, we investigated the *ferox* pod at high magnification to examine its microscopic composition and construction. SEM investigation brought into focus details of the seedpod's monocoque walls in which material sheets are laminated (like layers in plywood) to fill and insulate spaces between inner and outer surfaces (Figure 1, middle). Membrane and wall sections thus revealed the plant's strategies for plied, lightweight body construction. In contrast, the inner structure of the spikes are reinforced with tapering, stacked-cell networks for packing and strength (Figure 7, middle and right).

## Conclusion

If we contemplate intelligent architecture as Turinglike thinking machines with nuanced microbial intelligence, the notion of buildings in nature with non-human organisms, challenges most current studios practices. Pedagogically, the sourcing of biological attributes through scientific equipment, genetics, and computational programming then serves to technologically open pathways by which emergent intelligent architectures may inhabit nature and partner with biological life. In this context, not only evolutionary selection, but evolutionary engineering is active for metabolic architecture's adaptations of digital morphologies to support, for example, colonies of bioremediating microbial agents.

Provocatively, we move to answer our earlier Turing-inspired question, with yes: buildings can think. And, consequently, we close with another question from Turing:

*May not machines [buildings] carry out something which ought to be described as thinking but which is very different from what a [human] does?* (Turing 1950).



## Bibliography

- Baluška, František and Mancuso, Stefano. (2009) "Deep evolutionary origins of neurobiology." *Communicative & Integrative Biology*. 2:1. 60-65. January/February 2009.
- Bedau, Mark A. McCaskill, John S. Packard, Norman H. Rasmussen, Steen. (2010) "Living Technology: Exploiting Life's Principles in Technology." *Artificial Life*. Cambridge, MA. The MIT Press. 16: #1. 89-97.
- Clark, Andy. (2008) *Supersizing the Mind: Embodiment, Action, and Cognitive Extension*. New York. Oxford University Press.
- Dawkins, Richard. (1982) *The Extended Phenotype: The Long Reach of the Gene*. New York. Oxford University Press.
- Dollens, Dennis. (2014) "Alan Turing's Drawings, Autopoiesis and Can Buildings Think?" *Leonardo: The International Society for the Arts, Sciences and Technology*. Cambridge, MA. The MIT Press. May/June 2014. 47:3.
- \_\_\_\_\_. (2015) "Autopoiesis + Extended Cognition + Nature = Can Buildings Think?" *Communicative & Integrative Biology*. <https://www.ncbi.nlm.nih.gov/pmc/articles/PMC4594259/>
- Estévez, Alberto T. (2005) "Genetic Barcelona Project / Proyecto Barcelona Genética." *Metalocus*. Fall 2005. 17. 162-165.
- \_\_\_\_\_. (2006) "Genetic Barcelona Project: Cultural and Lighting Implications." *Urban Nightscape 2006*. Athens. International Commission on Illumination. 86-88.
- \_\_\_\_\_. Dollens, Dennis TR. (2007) "The Genetic Creation of Bioluminescent Plants for Urban and Domestic Use." *Leonardo*. February 2007. 40:1. 18.
- \_\_\_\_\_. (2015) *Biodigital Architecture & Genetics: Writings*. Barcelona, ESARQ (UIC).
- Falkowski, Paul G. (2015) *Life's Engines: How Microbes Made Earth Habitable*. Princeton, NJ. Princeton University Press.
- Hansell, Mike. (2005) *Animal Architecture*. Oxford. Oxford University Press.
- Mancuso, Stefano. (2010) "The Roots of Plant Intelligence." TED Global. [http://www.ted.com/talks/stefano\\_mancuso\\_the\\_roots\\_of\\_plant\\_intelligence.html](http://www.ted.com/talks/stefano_mancuso_the_roots_of_plant_intelligence.html)
- \_\_\_\_\_; & Viola, Alessandra. Benham, Joan, TR. (2015) *Brilliant Green: The Surprising History and Science of Plant Intelligence*. Island Press. Kindle Edition.
- Montebelli, Alberto; Lowe, Robert; & Ziemke, Tom. (2013) "Toward Metabolic Robotics: Insights from Modeling Embodied Cognition in a Biomechatronic Symbiont." *Artificial Life*. 19. 299–315. (2013).
- Oxman, Neri. (2015) "Design at the Intersection of Technology and Biology." TED Talk. [https://www.ted.com/talks/neri\\_oxman\\_design\\_at\\_the\\_intersection\\_of\\_technology\\_and\\_biology?language=en](https://www.ted.com/talks/neri_oxman_design_at_the_intersection_of_technology_and_biology?language=en)
- Reinitz, John. (2012) "Pattern Formation." *Nature*. 482. 464. 23 February 2012.
- Service, Robert F. (2016) "Rules of the Game." *Science*. 353 (6297): 338-341. July 22, 2016.
- Turing, Alan M. (1950) "Computing Machinery and Intelligence." *Mind, New Series*, Vol. 59, No. 236 (Oct., 1950), pp. 433-460.



\_\_\_\_\_. (1951) "Can Digital Computers Think?" TS with AMT annotations of a talk broadcast on BBC Third Programme. 15 May 1951. AMT/B/5. © P.N. Furbank. Accessed 20 October 2012. <http://www.turingarchive.org/browse.php/B/5>

\_\_\_\_\_. (1952) "The Chemical Basis of Morphogenesis." *Philosophical Transactions of the Royal Society B*, 237, 37-72.

Turner, Scott J. (2000) *The Extended Organism: The Physiology of Animal-Build Structures*. Cambridge, MA. Harvard University Press.



## Digital Fabrication in Education:

### Inside An Emerging Design Program

Louay Youssef  
Bennington College, Vermont, USA  
louayyoussef@bennington.edu

**Abstract.** This paper documents my experience interning at an emerging digital fabrication program at a private educational institution. I was able to explore the the capabilities and benefits of integrating digital fabrication into the educational experience. Through this experience, I was able to witness the potential for digital fabrication to enhance multidisciplinary education. When digital fabrication is utilized in an educational setting, along with an effective design thinking curriculum, students have the ability to enhance their own educational experience. Using digital fabrication as a learning method fosters students who are better prepared for the 21st century, not only through their technical knowledge, but also through their ability to think critically.

**Keywords.** *Digital Fabrication; Education; Design Thinking; Case Study; Democratization.*

## Introduction

Digital fabrication is a developing area for learning to take place. It allows students to use their creativity in order to bring their solutions, dreams, and ideas from a computer screen into physical manifestations. By pursuing digital fabrication as a learning mechanism, schools are able to integrate design thinking into their curriculum, which in turn, creates students that are better equipped for being 21st century thinkers. "Digital fabrication in education provides children with a sustained understanding of digital technology, and supports their ability to create with digital material, while affording access to a general understanding of the postmodern society mediated by digital technology." (Smith et al, 2015) As society continues to become more technological, students who learn to utilize digital fabrication will have greater insight into the world. While it does take some initial learning to familiarize oneself with CAD software and fabrication procedures, equipped with that knowledge, a student is able to engage with learning in an exciting manner that encourages active participation.

However, these skills are useless in a curriculum that does not make use of these tools and the creativity that comes with them. A D!Lab publication on creativity says, "if school and life do not require that we use our creative reflex, like a muscle, those skills become dulled and diminished." (James 2017) In order for digital fabrication to be utilized in an academic setting, a school's curriculum must adapt to allow students to learn and utilize these skills in the process of learning. Digital fabrication should not serve to replace academics, but instead, can and should supplement processes of learning, as well as be a medium for learning to take place through. Additionally, the creative skills and lessons acquired in the process of digital fabrication are based off of design principles, which are highly applicable to other areas of daily life. As digital fabrication technologies become more affordable, students will have greater access to these tools, and by familiarizing students with them in an educational capacity, students are placed in a position where they are better equipped to live in a society where design is becoming democratized. In this paper, I explore my experiences of being present while a school integrates digital fabrication technologies into its curriculum. I do this by delving into three case studies of how digital fabrication can be



integrated. The first instance focuses on my experiences with the head of the art department and a student who is working with fabrication in a class where everyone else is working in 2D. The second instance focuses on a class project where students worked to create solutions to a given prompt of fabricating a design that would hold up a poster board. The final instance is about a student D!Lab intern who has taken it upon herself to learn the software and tools in order to develop her own projects that expand the boundaries of what has been done so far with the school's tools. Before there has even been a class dedicated entirely to fabrication, these projects have each lead the way for others to integrate these tools in their own educations.

During the summer of 2016, the construction of a new building at St. Andrew's Episcopal School in Potomac, MD, USA, freed up space in its main building, allowing for the creation of a design thinking lab, which they named the D!Lab. The school had already began incorporating design thinking into different subjects, but this new space coincided with the acquisition of tools for digital fabrication. St. Andrew's has made technological literacy a priority at its institution. Six years ago, the school began a graduated rollout of computers, and now has a 1:1 laptop program from grades 3-12. The CAD program Rhino became available to students on their computers as the school purchased a Stratasys uPrint 3D Printer, a ULS laser cutter, and a Roland MDX-404 milling machine as a founding investment for the D!Lab.

For seven weeks in the beginning of 2017, I interned with the D!Lab, working with teachers to help integrate these tools into the curriculum of different classes. To me it was extremely interesting to experience the integrating of the technology with different areas of the school that had previously been physical or non-existent.

The D!Lab was founded by Charles James and the collaboration of teachers in the visual arts and sciences. However something that makes the program so interesting is that it has been encouraging teachers from different disciplines to use the technology. It also decided to buck the trend of other schools, and had already established a design thinking program influenced by neuroscience before the D!Lab was established. The D!Lab only has half its space designated to digital fabrication technologies. The other half is filled with tables, whiteboards, a projector, and useful tools. The D!Lab is not only a room for digital fabrication, but is also space for brainstorming, collaboration, and creativity. This creates an atmosphere where the process of creating is included with the actual tools.

## Arts

One teacher that I worked with was Lauren Cook, the head of the art department. Cook is an accomplished artist who was eager to see what the D!Lab could do for her classes, as well as her own work. She wanted to explore how she could utilize the laser cutter in order to carve drawings that her students did into stamps that would allow the students to printmake their work. We wanted to create the best method that we could for this, and so we began a long process of testing laser cutter settings and different materials to find out what would be the best for this outcome.



Figure 1. Exploratory laser cuts of Lauren Cook's head.

While working on this project, she introduced me to a student in a studio art class. While all the other students in the class went about completing their assignments in 2D, this student instead preferred to work in 3D. He had been working with clay, but was not very comfortable with it. She wanted to see what would happen if he could instead learn and utilize the technology in the D!Lab and so she invited me to visit his class and work with him.

When I began working with him, he was in the middle of a project where he was trying to create an armadillo. So far, he had purchased different types of cups, but was having difficulty building a representation of the animal out of them. I got to work teaching him the basics of Rhino, and he caught on very quickly. With a knowledge of the software basics, he designed several cross section cuts of the armadillo that, when slid together on a thin slice of cardboard, successfully resembled the animal. In this case, the use of CAD and digital fabrication provided the student with a different means of completing the given assignment. Everyone else in his class had drawn their respective animals, and yet with the use of this technology, he was able to visualize his object 3 dimensionally using spacial awareness.



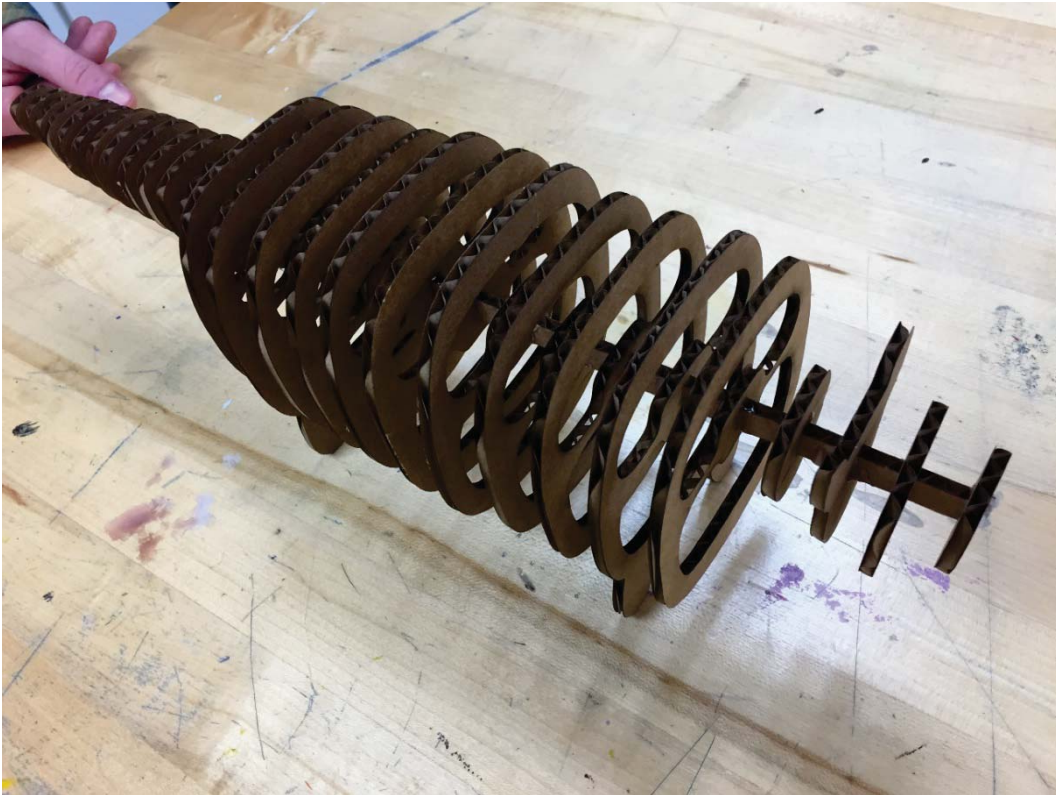

Figure 2. Finished armadillo assembled.

## Robotics

St. Andrew's has long had a project called the Oral History Project, where student interview significant people from history and compile these interviews along with research into a final paper. This culminates into Oral History Night, in which students present their projects to parents, interviewees, and family with poster boards. These poster boards had always relied on poster board supports, which are clunky and expensive. Early in my internship, I designed and laser cut a functioning poster board support out of cardboard that was cheaper and friendlier to the environment. News of this project spread around and I was soon contacted by science teacher Dr. Ian Kelleher, who thought that it would be a great introduction to Rhino for the robotics course that he teaches. In preparation for this project, I created a series of instructional videos and improved my original design, although for the instructional videos, I used a simplified version of my design that probably would not have worked so that student would have to be original. When students came into the the classroom, they began with a design thinking exercise where they were given a bowl of goldfish and had to arrange the goldfish to make different patterns, an exercise that got their creativity going. They were then introduced to the project.

For the first day, they were given paper to sketch ideas onto. They were told to make as many as 10 different sketches, and Dr. Ian Kelleher added that at least one of the ideas should make others laugh. At the end of class, they were given links to my instructional video and were told to explore Rhino as the homework for the next class. While it was evident that many of them did not do their homework, they all came in the next class ready to work on their favorite design. It was astonishing how fast they did manage to gain an understanding of working in Rhino, and before long they were laser cutting their ideas out of cardboard. Many of these first cuts needed more

work, and after students perfected their design, they were allowed to laser cut using acrylic. The most amazing thing for me is that even though we all had the same prompt their projects differed from mine and from their peers. I had assumed that my original solution was the most simple and obvious, but the students managed to better utilize material, with their designs still being stronger in some cases. Through these steps, students were exposed to the design process while getting to physically materialize their ideas. Not only were they able to bring an object to completion, but they were able to produce their final designs without human error destroying the appeal of it.

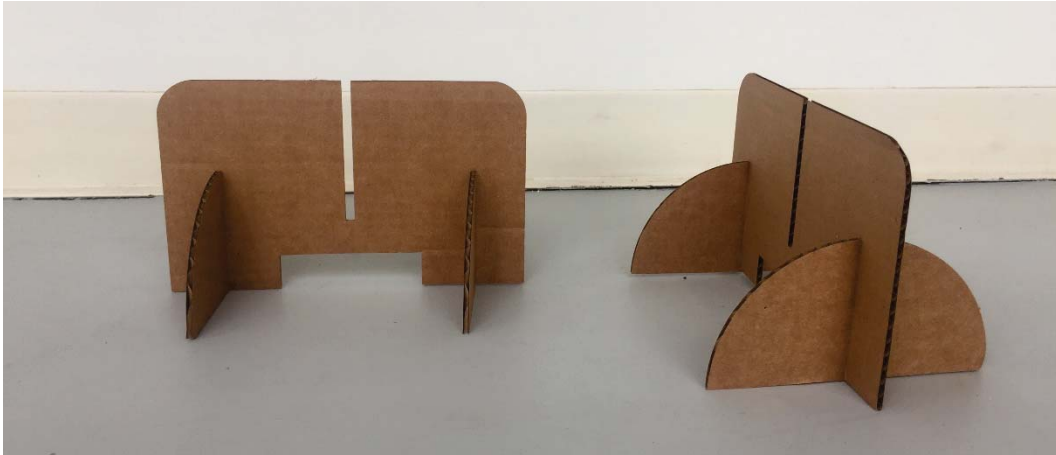

*Figure 3. My finished poster board holder design.*

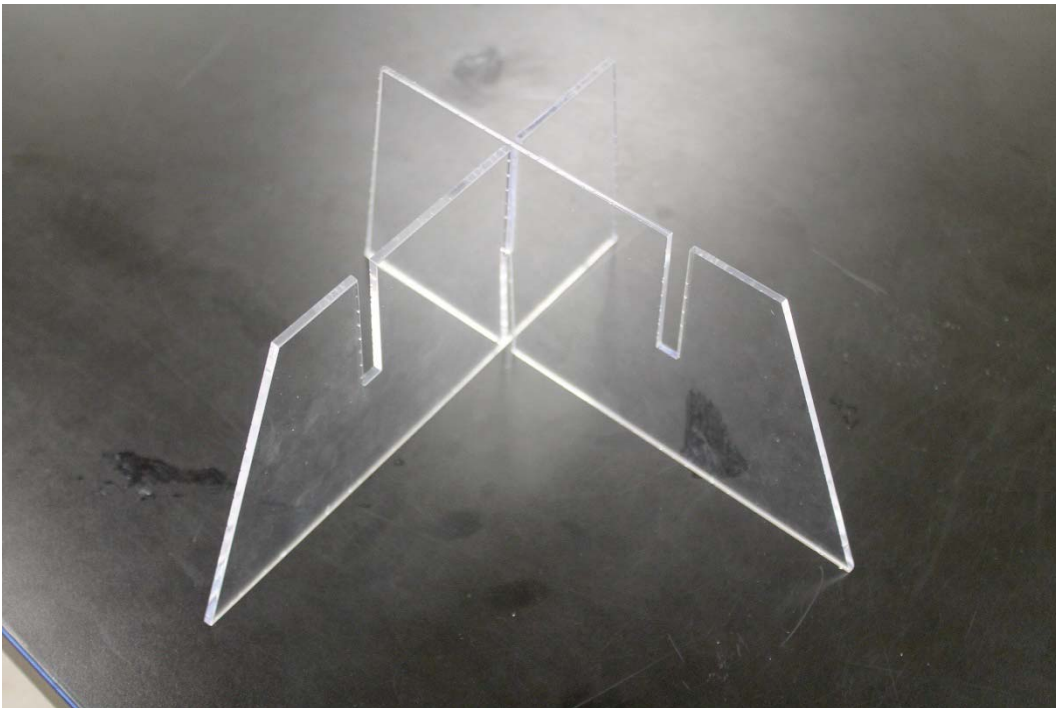

*Figure 4. A student's poster board holder design.*

## Independent Student Work

Probably the most rewarding thing of this internship was working with self driven students who were developing their own projects and got to see them come to life in the machines. One student in particular came in on a day with a design for how to laser cut the Eiffel tower. When I looked at her project, I realised that she had not designed it in Rhinoceros but instead had used functions that I was not aware of in Illustrator to complete her project. It was one of the many instances where I learned despite being in a teaching role. We went through the design process together of making models, testing them to see if they worked, and then tweaking the results in order to improve it. The final result was a well created model of the Eiffel tower.

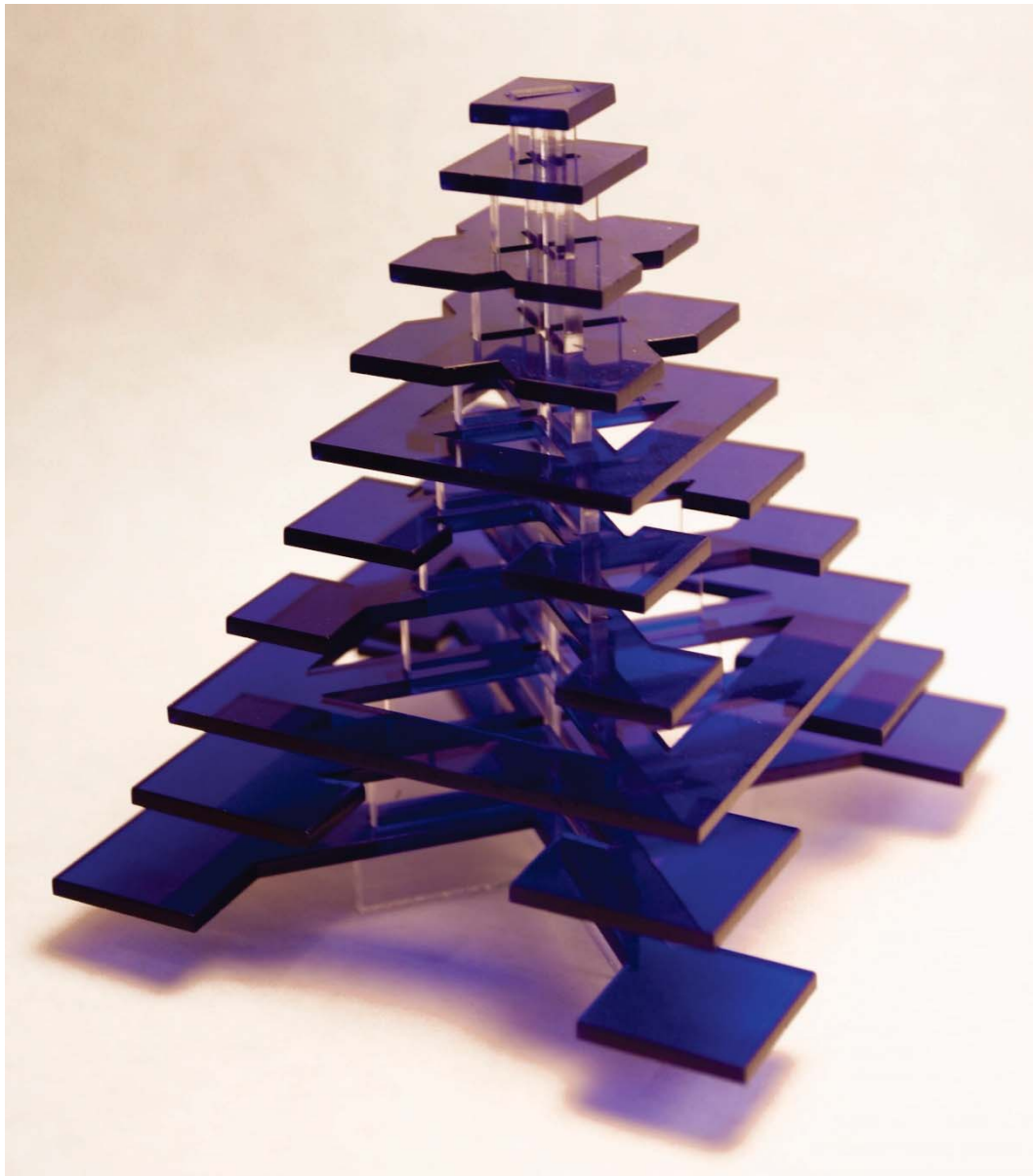

Figure 5. [Eiffel Tower] Student's final laser cut Eiffel Tower.



After a 3 day weekend, she came to the D!Lab having taught herself Rhino, with a new project in mind that this time involved a moving element. As a lever was spun, a rotating mechanism would move a series of bars inside of a laser cut housing. The design was redone several times, but unfortunately, I had to leave before the project could be completed. When I followed up with her, she said that she had abandoned the project, because she was having trouble with it and it stopped being fun. Because the project was self-driven, it was much easier to abandon when frustration set in. However, she told me that she would look into doing more work with it.

## Relation to Other Work

There is a limited number of case studies that address the effect of digital fabrication on learning, however, I have offered a few below.

Corum and Garofalo's paper explored the effect of 3D digital fabrication on student's understanding of surface area and volume in mathematics. Students each created three-dimensional cubes and rectangular prisms that were used to help them explore the subject. The researchers found that "student's performance on the surface area and volume tasks improved dramatically following their participation in the digital fabrication-augmented units." (Corum & Garofalo, 2016) While I did not have the opportunity to work with any of the mathematics faculty, I believe that the results would have been the same. Through the other areas that I worked with students on, they became more interested in the subject matter thanks to the technology, and this engagement inherently leads to better retention.

Shaunna Smith followed a teacher for a year who was utilizing digital fabrication to help teach low-socioeconomic urban middle schoolers Language Arts at an afterschool program. In this program, students were tasked with creating pop-up books using laptops, an inkjet printer, and a machine that trimmed 2d materials using vector based software. Smith found that "when integrated thoughtfully in connection with content and pedagogical needs, digital fabrication can effectively provide students with an opportunity to engage in hands-on discovery learning and creative self-expression. (Smith, 2013)

Assistant Professor at Princeton, Paulo Blikstien (2013) wrote about "keychain syndrome," an issue that he has come across in workshops. Blikstien found that instead of students pursuing technically difficult projects, workshops became keychain factories. Students would learn the basics of the digital fabrication technologies, but became obsessed with the creation of simple objects, because they came out aesthetically pleasing. We experienced this a lot at St. Andrew's especially with students finding simple fidget toys online and wanting to mass produce them. Although they were utilizing the machines, there were not utilizing their creativity. According to Blikstien, the solution to this is to have playful environments, where students are encouraged to go beyond uninventive objects. Our solution was to ban the printing of downloaded spinner toys and we instead encouraged people who wanted to make spinner toys to design them themselves.

## Conclusion

These tools currently remain out of reach for most educational facilities due to their prohibitive costs. Digital fabrication, however, has the potential to follow in the steps of computers, with which educational integration began in only the wealthiest of schools. As computers became cheaper, the digital divide was breached and they have now become commonplace in a majority of schools. As the cost of digital fabrication technologies go down, and the rate of technological literacy goes up, we will see these tools become even more common throughout education. As more students become exposed to this technology, the student is empowered to create as part of their education. Blikstien (2013) writes that with digital fabrication, "children could actively construct with technology rather than just consume technological products." This ability to have a technological role in an



increasingly technological world, changes the role of students from idle learners to active learners who can shape their education. The case study presented in this paper of a developing design thinking program, and the supporting examples of student's fabrication work, shows a way forward for fabrication to blossom in education.

## References

Blikstein, P. (2013). *Digital Fabrication and 'Making' in Education: The Democratization of Invention*. In J. Walter-Herrmann & C. Büching (Eds.), *FabLabs: Of Machines, Makers and Inventors*. Bielefeld: Transcript Publishers.

Corum, K. & Garofalo, J. (2016). *Learning about Surface Area through a Digital Fabrication-Augmented Unit*. *Journal of Computers in Mathematics and Science Teaching*, 35 (1), pp. 33-59. Chesapeake, VA: Association for the Advancement of Computing in Education (AACE).

James, C. (2017). *Creativity Counts*. Center for Transformative Teaching and Learning, Maryland. 2017

Smith, R, Iversen, O & Hjorth, M. (2015). *Design thinking for digital fabrication in education*. *Int. J. Child-Comp. Interact*, 5, C (September 2015), 20-28.

Smith, S. (2013). *Through the Teacher's Eyes: Unpacking the TPACK of Digital Fabrication Integration in Middle School Language Art*, *Journal Of Research On Technology In Education*, 46, 2, pp. 207-227, Academic Search Premier, EBSCOhost, viewed 25 April 2017.





## Re-morphing the Amorphous

### Creating New Urban Substance

Yannis Zavoleas<sup>1</sup>

<sup>1</sup>*The University of Newcastle Australia*

<sup>1</sup>*Y.Zavoleas@newcastle.edu.au*

**Abstract.** This paper pertains to a broader research area wherein systemic references are employed to inform spatial articulation, operations and overall behaviour being applicable to architectural design. Design is approached as a dynamic process in analogy to those found in nature, being about energy exchanges causing interactions and transformations with regards to the parts and the whole. For this particular study, “amorphous” phenomena of the urban context are activated and further manipulated towards spatial propositions through methods and techniques generally described as “re-morphing.” Metaphors from geology and biology are borrowed as an asset of concepts, ideas, organizing modes and formational strategies, assisting to develop alternative ways for interacting with the urban milieu.

**Keywords.** *Dynamic Simulation; Multi-Agent Systems; Computational Tools.*

## Introduction. Natural Sciences Informing Geo/Bio-Systemic Thinking

In architecture, advanced modes of study related to computation such as parametrics and simulation dynamics are often appointed to understand physical space through an all-systemic logic being similar to those found in nature. Elements of the landscape, the ecosystem, the energy resources, the geo-political site and the socio-cultural context are cross-connected as systemic components with regards to their influences, performances and interrelated behaviours forming integrated entities. Processes of analysis generally assume that the subject of focus is identified to its constituents, which are recorded as data. Such a reduction of “concrete” reality to abstract manifestations of it infers to numeric, graphic and diagrammatic representations and it is necessary so that complex phenomena become calculable and also that it is possible to relate and compare the parts with regards to their mutual compromising and load-sharing in setting the whole. As this process is transferred to architecture, the models being proposed offer alternative formulas to examine intricate spatial conditions and to better integrate them with the existing fabric, effectively carried through to architecture’s tectonic logic also with regards to order, structure, body and skin. New architectural and urban themes of natural reference may be generated as creative ways to deal with the urban milieu, transforming the code consistency of the human-made environment, offering novel solutions to problems often of no prior reference (Figure 1).

The analogy between architecture and nature was built around the early 1910s and since then it has outlined a topic of ongoing interest. Biologist Geddes (1915), studied the development of cities from a sociological point in analogy to biological processes. Geddes elaborated specifically on dynamic functions associated with the initial formation and the evolution of human settlements. He further explored the interdependencies among organizational patterns, natural resources, environmental factors, capital flows,

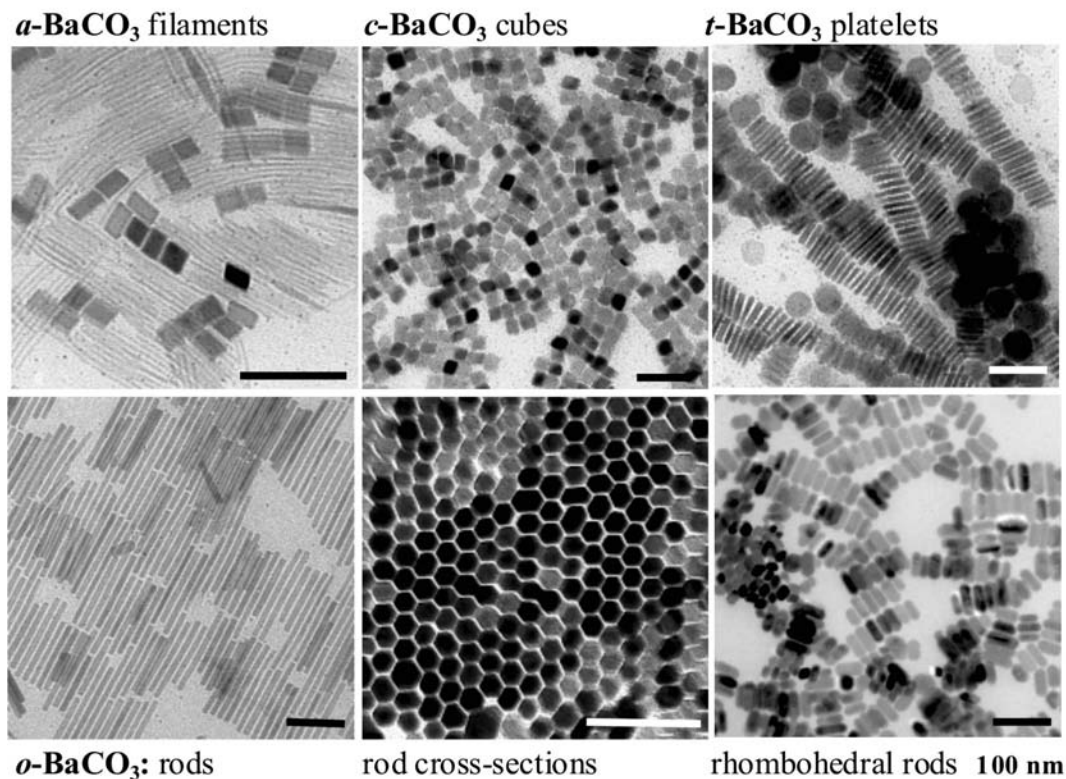

Figure 1. Nanoscopic re-crystallisation patterns, nanoparticles in structural biology.

labor distribution and human needs found variously into any society. Another key figure was Doxiadis, who formed an extended interdisciplinary research group around the 1960s to study the affinities of human settlements with systems of biological origin. He came up with holistic models about the global ecosystem manifesting the analogies between cities and natural entities seen as organic totals in constant flux. In the 1970s and 1970s, Otto projected the analogy onto the processes of formation to propose new approaches to architectural design being the result of performative operations, rather than ones relying solely on aesthetics. He employed form-finding techniques to scrutinize structural efficiency (Drew, 1976). More original architectural expressions would emerge from within, that is, ones stemming directly from physical and environmental constraints and the broader earth system, rather than from established preconceptions. At the basis of such endeavours is the observation that architecture and nature share in common the view that an element is conceived, analysed through and live along with its indissoluble connection with the greater environment it belongs to. As this idea has been adapted to architecture, more than merely offering formal patterns and themes to imitate, it has enriched architectural discourse with an interdisciplinary asset of references, analogies, tools and techniques addressing spatial conditions and managing their influences upon an architectural project.

With the advent of computing, operations related to dynamic simulation and scripting have helped to frame the above analogy in more accurate terms. In the recent decades, research groups have been formed around this theme, which has been incorporated into the main research agenda and the educational curriculum of major institutions. The related groups have attempted to readdress the analogy from a rigorous scientific perspective (Frazer 1995) by utilising techniques that are mostly reliable for registering and manipulating information about design being about



systems in constant flux. With digital tools approximating behaviours, phenomena and relationships even in real-time, it is possible to apply an all-encompassing approach about architectural design seen as a performative process (Hensel and Menges, 2007). The related actions assume producing models that are suitable for testing ideas during design's intermediate steps until final resolution. Extensive data analysis, processing and recursive experimentation are main (pseudo-)scientific applications directed to produce form. Parametric tools have been used to break down a problem into systemic variables described by their dynamic properties in preparation for their interaction. Computation may assist in the management of a set of agents acting as self-organizing principles during morphogenesis (Weinstock, 2004). In effect, it has been possible to construct the whole set of influences describing architectural content into models with reference to natural sciences and so to emphasize on architectural design's systemic character via multi-agent thinking.

## Multi-Agent Systemic Thinking as An Alternative to Aesthetics

Systemic thinking is commonly employed into design to explore the influences of extended data inputs. Initially developed in the 1960s with reference to Cybernetics (Pask, 1969), the underpinning idea has been to describe a design problem with regards to autonomous agents interacting with each other forming larger systemic entities. Same as in nature, elements of an artificial setting do not function in isolation, but rather as parts of the broader environment they belong to. Agents are employed to pursue goals or carry out tasks in order to meet design objectives and in general the resulting outputs may be supplementary as well as conflicting to each other. Multi-agent logic has helped to understand, manage, and use distributed, large-scale, dynamic, open, and heterogeneous computing and information systems (Weiss, 1999), which are rendered more resilient, robust and reliable in managing the sum of variable inputs towards desirable aims.

The tentative list of agents in architectural design may include contextual factors as traits making the architectural system. These may be about the site, proximities and surroundings, energy, movement, connections and traffic with entry points, regulations, restrictions, enduring and changing conditions, social facts, economy, culture, existing and proposed activities, functions and the program (Ballantyne, Kawiti and Schnabel, 2016) (Figure 2). The agents are introduced as data sets and rules to express their behaviours and properties, along with the intensity of their impact as ways to outline relationships to be carried out by the proposed scheme. Design is viewed as the result of complex relationships between these agents and moreover there is direct connection between the inputs and the occurring form and vice versa.

With advanced computation, multi-agent applications have opened up new potential about design outside its conventional aesthetic framing. For example, in answering a brief, it is common to analyze information to a series of data inputs. In a traditional approach, most often it has been beyond the designer's control to measure and manipulate the influences acting upon each other often in uncontrolled ways and so the result would mostly rely on intuition, or talent. Additionally, relating initial data inputs

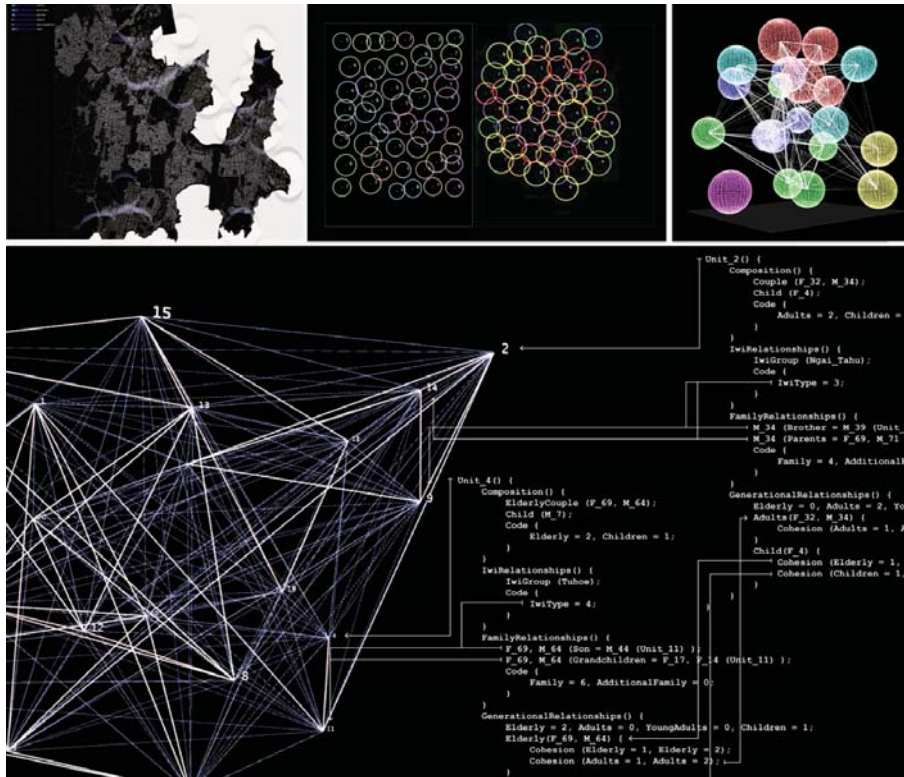

Figure 2. Simulations of socio-cultural behaviors as systemic agents forming relationship structures (Ballantyne, A., Kawiti, D. and Schnabel, M.A., *Urban Papakainga: Programming Cultural Criteria, by using Multi-Agent Systems*, 2016).

to each other via a system suggests more controlled ways to approximate their influences. A design problem is addressed through systemic data analysis and pursued through engineered responses. A design proposition becomes the result of iterative processing, testing and progressive assessment as opposed to subjective judgement. Moreover, with software currently available, data inputs can be simulated and manipulated with operations linking multiple agents together. Ideally, an output scheme may refer back to these inputs and so it is possible to calculate their effect upon the project. In effect, agent-based approaches have prompted to describe design as one about science, wherein the produced data and functions are interpreted, processed and gradually adapted to provide answers by employing computational methods of much higher reliability.

In extending the above, advanced computational methods related to dynamic simulation for real-time testing are applied onto information describing "amorphous" situations of the urban context to suggest their interaction as agents of a systemic whole. An architectural design problem is analysed with regards to multi-agent logic; then, the produced data are interpreted, manipulated and adapted with the aid of dynamic methods and tools offering solution schemes.

## From Amorphous to Re-morphing. Process Describing Spatial Transforming

"Amorphous," meaning without form or shape, may describe latent systems being inert due to causes such as high entropy, decay and death. In geology, amorphous refers to elements (solids or liquids) lacking the long-range order characteristic of crystalline structures, attributed to the fact



that atoms and molecules are not organised in definite lattice patterns. It is used to describe residues, magma, or pulp of high viscosity and dormant matter, being the result of destructive processes such as deterioration, oxidation, erosion, sedimentation, solubility, dissolution, dissipation, decomposition and disintegration. From a chemical point, it refers to non-crystalline materials such as glass, gel and plastic lacking crystals in their molecular structure. In biology, amorphous may be attributed to irregular, vague, anomalous, or undefined shapes and structures, also ones without distinct purpose.

Through processes of re-morphing, amorphous may turn to re-crystallisation, new consistencies and new species. Related natural phenomena include diagenesis, metamorphism and other geo/biogenetic processes such as dislocation, lithification, dolomitisation, liquefaction, porosity, alteration, transformation and mutation. Re-morphing reduces a system's entropy. It refers to mechanical (macroscopic, extensive traits) and chemical (micro/nanoscale, molecular, intensive properties, inner code) processes enacted by forces, temperatures, pressures and environmental constraints, leading to the genesis of new order, materials and features. Energy releases and other external factors act as dynamic agents affecting consistency, DNA, structure and form towards more active behaviour, interaction with the surroundings and overall resilience.

An analogy is suggested between re-morphing processes of nature with those being about spatial transformation. Re-morphing in urban and architectural context may talk about the activation of processes of formation such as new interactions with the environment at macro (urban, permanent, long-term) and micro/nano (local, architectural, ephemeral) scale leading towards new structures, organisations and meaning. The purpose of spatial re-morphing could be to introduce scientific-driven ways of analysis leading to synthesis, along with the employment of dynamic tools and techniques as ways to simulate, express and manage the set of agents that have traditionally influenced design by way of intuition, this present time in more consistent manners. Accordingly, re-morphing may assist to include behavioural, interactive and performative operations performed during the initial phases of design directed to data gathering, analysis, processing and form-finding. Given its affinity to science as outlined above, re-morphing may bring about new terminology into architectural vocabulary with notions and concepts of bio/geological origin being applicable across various scales of the physical space, also with regards to its dynamic character. In effect, spatial re-morphing may explain the urban setting as a highly sophisticated phenomenon, informed by energy exchanges and feedback among the participating agents of the inner and the greater context.

## Setting the Problem and the Methodology

For the purpose of this case study conducted for an advanced design research studio, analysis starts with a theme of natural origin carrying amorphous' main characteristics. The first phase involves analyzing a natural phenomenon. Selected themes include lightning structures and their footprint effect onto different material such as glass, sand and timber for project 1 (Figure 3); processes of sedimentation and development of residues supported by web structures for project 2 (Figure 4); material dynamics with reference to the geological movement between solid ground and water flow for project 3 (Figure 5); symbiotic relationships and growing patterns of corals developed as ways of interaction within their natural setting for project 4 (Figure 6), and; additive processes being reminiscent of wasps' nests for project 5 (Figure 7). The selected theme is broken down to its constituent elements and the rules setting the relationships between them, then modelled through analogue and digital techniques. Such a method refers to reverse engineering, whereby a fixed entity is analysed to its parts through data-gathering and series of abstractions further tested, compared and explained with regards to each other. An intention to reorganize the parts prompts towards new strategies described as Design Research Hypothesis.



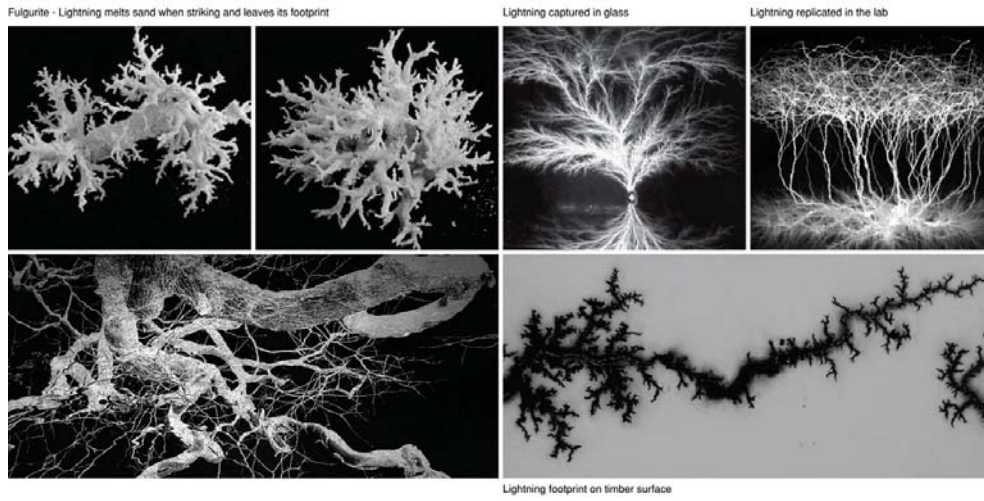

Figure 3. Project 1: Lightning footprints on different materials (Tri-Nghia Phan, N., Re-morphing the Amorphous, 2016).

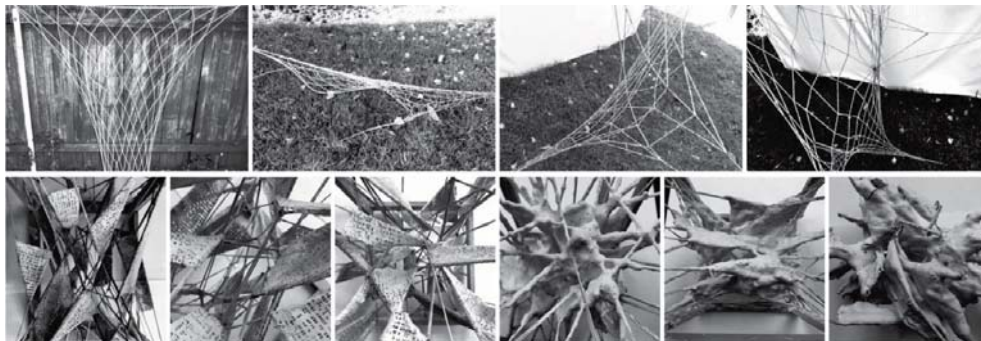

Figure 4. Project 2: Model testing of residual formations supported by web structures (Sparks, K., Re-morphing the Amorphous, 2016).

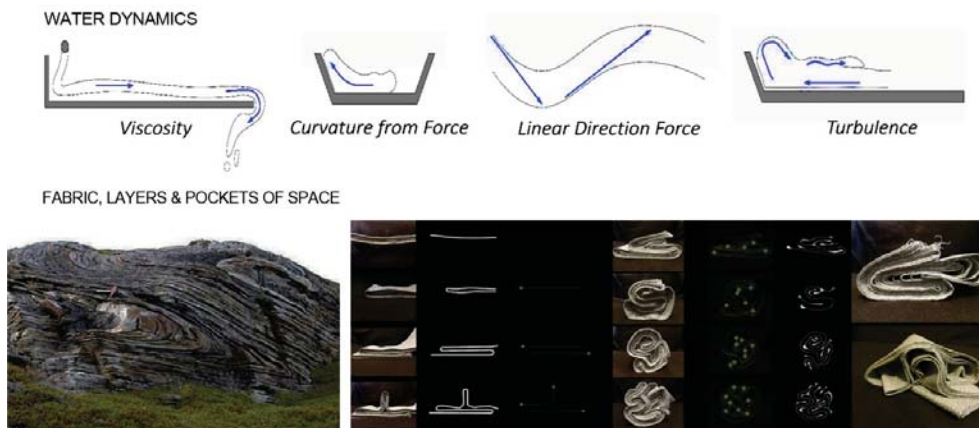

Figure 5. Project 3: Geological forces of water and rocks creating space pockets (Alley, A., Re-morphing the Amorphous, 2016).

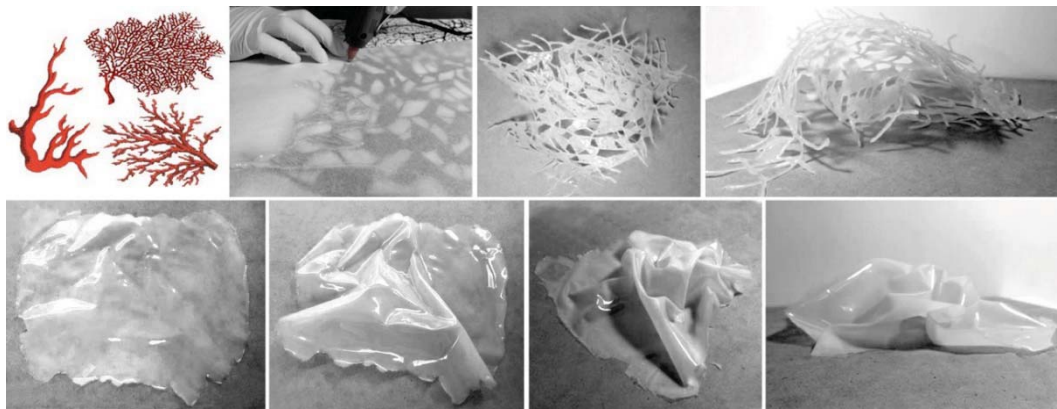

Figure 6. Project 4: Red Coral structure remodeling (Reyes Castillo, N.A., *Re-morphing the Amorphous*, 2016).

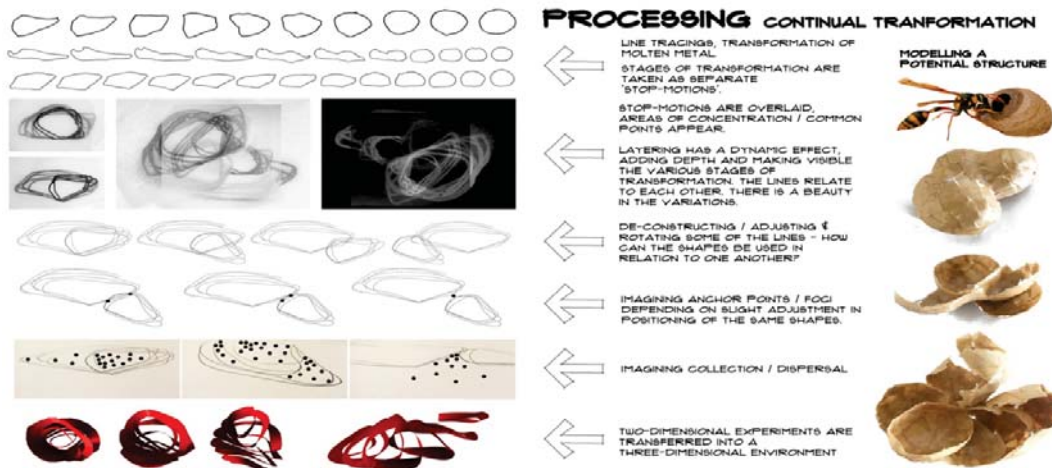

Figure 7. Project 5: Additive processing reminiscent of wasps' nests (Johnstone, J., *Re-morphing the Amorphous*, 2016).

In the next phase, the hypothesis is related to amorphous-like situations of the urban fabric. Sites being in a state of dormancy are being proposed, offering semantic analogies with the scientific amorphous counterpart. An Argument is crafted bringing together the Design Research Hypothesis with the site. The design problem is described as a set of agents interacting with generic geometric references via form-finding processes to produce alternative schemes. These agents refer to activities, site conditions, proximities and other parameters locally defined acting as generative forces. Dynamic simulation, animation and other advanced modelling techniques are directed towards some kind of re-morphing, gradually adding architectural significance to the project. Related themes are: linear ruptures created by interacting with the urban setting to create 3D net meshes that reconnect parts of the city (project 1); void fill-in strategies activated by traces of activities currently occupying the walls, which form the boundary of the site and a layered history of its use (project 2); fabric, layers and pockets of space created as a result of the impact of forces of geological materials of different consistency (project 3); dynamic expansion of a network structure at varying concentrations supporting the symbiotic relationship between public and private

through activities related to surrounding buildings (project 4), and; tectonic strategies to respond to unregistered events happening within the site area through unique components and dynamic mesh mold techniques (project 5).

The final step is to further adapt re-morphing to a selected site by producing new architectural substance with reference to architectural traits, living conditions, activities and relationships with the urban setting. Following the analogy with nature, a design scheme becomes a sort of re-crystallisation, progressing through recursive testing by its interaction with urban influences. The study concludes by demonstrating an overview of the design's focal points and the paths being pursued. Prototype models assist to examine the general logic with regards to onsite placement and fabrication solutions. It has been decided that projects of high relevance merge together forming larger group projects and so the final results are enriched with more references and have been developed to larger prototypes, with higher consideration of material choices and in some cases construction at physical scale. Projects 1 and 2 have been combined to a study about kinetic definition of surface interacting with adjacent activities to provide shading, protection and seating, as a way to activate temporary and permanent vacant lots (Figure 8). Projects 3 and 4 have offered an inflatable 3-dimensional layer above the ground, placed at urban squares and voids. Porosity patterns at varying sizes offer alternative ways of occupation and a symbiotic relationship among groups and the urban setting (Figure 9). Project 5 has ended to a support structure made of unique components of paper and recycled materials, set to "re-charge" underused parks in proximity with existing buildings (Figure 10).

These design projects were driven by a research focus and experiment process. The participants were guided to form and test hypothesis in the aim of a systemic application about architecture linked to natural processes that responds dynamically to forces irrespective of traditional architectural typologies. References of natural origin were selected and were analyzed to their formative causes, then adapted to relate to the urban setting. The results draw upon different interpretations of amorphous situations of the urban context. The solutions being proposed question established notions about urban intervention, by also employing techniques and methods that depart from the conventional architectural toolset to merge with those of the scientific framing.



Figure 8. Projects 1 & 2 combined: Kinetic definition of surface interacting with adjacent activities as a way to activate vacant lots (Tri-Nghia Phan, N., Sparks, K., *Re-morphing the Amorphous*, 2016).





Figure 9. Projects 3 & 4 combined: Inflatable layer above the ground offers alternative ways to occupy the urban setting. Prototype structure adapted and fabricated at natural size at the studio space (Alley, A., De Belle, B., Reyes Castillo, N.A., Triantafyllou, C., *Re-morphing the Amorphous*, 2016).

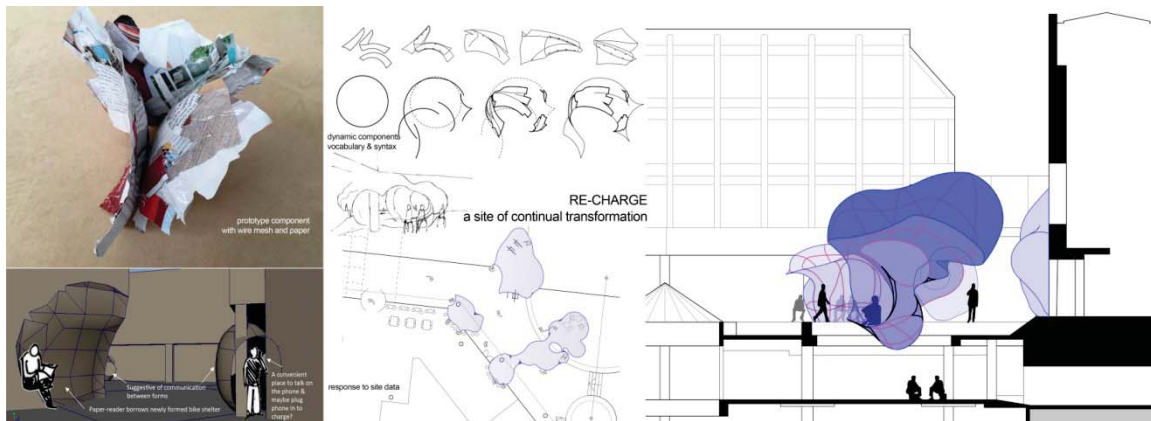

Figure 10. Project 5: Structure made of unique components, set to "re-charge" underused parks in proximity with existing buildings (Johnstone, J., *Re-morphing the Amorphous*, 2016).

## Conclusion

This paper's main scope has been to suggest a foundation of the research project described above, also in an attempt to outline an interdisciplinary potential for architectural design. First, it has drawn upon nature as an asset of references related to multi-agent systemic thinking being translated into architecture, by providing a list of related precedents. There are many analogies between the built environment and natural phenomena, prompting to approach a design problem of any kind via systemic logic. With the advent of computation, it has been possible to expand the analogy between architecture and nature beyond the mere visual towards behavioural aspects. Advanced techniques such as dynamic simulation, scripting and progressive modelling have assisted to respond to a wide range of scenarios about systemic design assuming the architectural edifice to be part of the broader ecology, aiming to re-establish consistent links with the multifaceted set of parameters influencing architecture.

The above view has set the strategy to analyse and respond to urban related case studies. The produced variations involve activating parts of the urban fabric lying dormant for long hence described as "amorphous" via some kind of "re-morphing." Analysis of natural phenomena has helped to understand the dynamic operations performed in multi-agent systems, as well as to



propose a vocabulary then appropriated into architecture. Related processes have been applied to represent architectural parameters as urban agents dynamically affecting design solutions. As such, these parameters have been activated to form the first schemes, then translated and refined into design propositions and fabricated prototypes. The outcome has offered new typologies, shape characteristics and spatial conditions as new urban substance.

## References

Ballantyne, Ariana, Kawiti, Derek and Schnabel, Mark Aurel, "Urban Papakainga: Programming Cultural Criteria, by using Multi-Agent Systems", in Zuo, Jian, Daniel, Lyrian and Soebarto, Veronica (eds.), *Revisiting the Role of Architectural Science in Design & Practice: 50th International Conference of the Architectural Science Association 2016*, pp. 79-88, Architectural Science Association & The University of Adelaide, Adelaide, 2016.

Doxiadis, Constantine, *Between Dystopia and Utopia*, Faber & Faber, London, 1966.

Geddes, Patrick, *Cities in Evolution*, Williams & Norgate, London, 1949 (1915).

Frazer, John, *An Evolutionary Architecture*, Architectural Association, London, 1995.

Drew, Philip, *Frei Otto: Form and Structure*, Crosby Lockwood Staples, London, 1976,

Hensel, Michael and Menges, Achim, "Towards an Inclusive Discourse on Heterogeneous Architecture", in Hensel, Michael and Menges, Achim, (eds.), *Morpho-Echologies*, pp. 16-60, Architectural Association, London, 2007.

Weinstock, Michael, "Morphogenesis and the Mathematics of Emergence", *AD Emergence: Morphogenetic Design Strategies*, vol. 74, issue. 3, pp. 10-17, Wiley, London, 2004.

Weiss, Gerhard, *Multiagent Systems: A Modern Approach to Distributed Artificial Intelligence*, pp. 1-9, The MIT Press, Cambridge MA and London, 1999.



## A Study on the Materialisation and Formation of Mycelium in a Fabric Formwork

Gulay Elbasdi<sup>1</sup>, Sema Alacam<sup>2</sup>

<sup>1,2</sup>Istanbul Technical University

<sup>1</sup>gulayelbasdi@gmail.com, <sup>2</sup>semosphere@gmail.com

**Abstract.** This paper introduces the findings of a series of experiments with Mycelium-based material (MbM) made through investigating the materialisation of mycelium by using an adjustable fabric formwork which is under certain forces. The aim of the study is to explore the potential usage of mycelium as a binding agent in a free-form architectural geometry since mycelium acts as a natural self-assembling glue. The growth and formation process of mycelia of *Pleurotus ostreatus* were investigated in 6-day cycles, thus the interrelations among MbM, fabric layout and various forces have been examined in a repeatable and structured experiment setup. Apart from presenting the outcomes and findings of the structured experiment, the current research will attempt to contribute to the theoretical discussions by questioning the common understanding of materialisation of design ideas.

**Keywords.** Fungal-Based Architecture; Emergent Behaviour; Form Finding; Fungal Growth

### Introduction

The increasing tension between artificial and natural, intangible and matter, digital and physical, programmable and spontaneous have called forth the necessity of seeking for new ontologies and new ways of making things in digital age. Likewise, the interest in material studies in the field of design has been increasing in the last decades. Pink et al. (2016) criticised this dilemma as the dominance of the intangibility of digital over the physicality of matter. However, this dominance has begun to change in the advantage of the material studies. As Gramazio and Kohler manifested, "Materiality is increasingly being enriched with digital characteristics, which substantially affect architecture's physics" (Gramazio and Kohler 2008, p. 7; Pink et al. 2016, p. 26). The transition of the focus in design from being a matter towards becoming a material leads to the emergence of new perspectives and understandings for the biological complexity and its computational potentials. Self-organization in biological material systems and emergent behaviour derived from simple interactions in complex systems (Hensel et al. 2010) becomes a field of play for architects to explore further. Thus, physical workspaces, becoming widespread recently, for designers enable experimenting both the living organisms and material systems by providing a potential for presenting a deeper understanding of how the mechanisms of living organisms work.

Bio-based materials with generative potential offer broad use in functional and structural performance and form generation within architecture. On bio-based materials, Mallick (2008) states that composites consisting of a ductile matrix and high-strength reinforcement offer high performance at low cost and freedom in designing material for a particular application. Latest studies in bio-based material design depict that the vegetative part of a fungus consisting of a network of fine white filaments, called mycelium, could be an alternative for these matrices. This study particularly aims to unfold the discussions on shaping and re-shaping capabilities of mycelium-based materials (MbM) by exploring formation and materialisation of mycelium. In the scope of the study, the main motivation behind suggesting the experimental methods for expressing the procedures of biological growth –in this case, fungal growth- is to understand its structure as well as to exploit relations which could be adapted to a different context. Direct observation of

nature, in this case mycelium, enables a designer to achieve reflection, conceptualization, and to derive abstraction, calculation etc. Despite the fact that hyphal growth of mycelium has already been investigated; by monitoring the structure and bifurcation of the hyphae of mycelium, it is expected that we might be able to unveil some computational system behind the hyphal growth of mycelium.

The physical experiment setup consists a variety of initial geometry alternatives and the formation is observed and measured numerically by time-based recording on top and section views. Experiments were documented as a process of formation with the help of digital tools.

All in all, this study aims to contribute both to the design research literature and scientific knowledge to integrate living systems into the material design by encouraging collaborative interdisciplinary research, thereby positioning the designer as a decision-maker from the very beginning of material design process.

## Experiment Setup for Observing Materialisation of Mycelium

This section introduces a structured experiment, its constraints and methodology. The aim of this experiment is to perform an explorative research to determine the formation of a mycelium-based material by means of experimental observation and empirical testing of a coinciding material, the MbM. In order to demonstrate the process of the experiment, the following items will be explained:

- Initial Experiments: Learning from empirical observations and preparations for experiment set-up
- Constraints that obtained from the growth tests
- Process and implementation

### Initial Experiments

Before the structured experiment setups are defined, we studied the property of mycelium from micro to macro scale. Initial experimentation processes demonstrate that becoming a form mainly depends on the constraints of materialisation of mycelium. The process is specific for each experiment due to the different ratio and density of ingredients, environmental conditions -such as level of moisture and temperature- and design space. Since mycelium itself is comprised of living cells, it has specific growing conditions which must be taken into consideration. That is why it is important to mention that such growing conditions presented here are mainly special to mycelia of *Pleurotus ostreatus*.

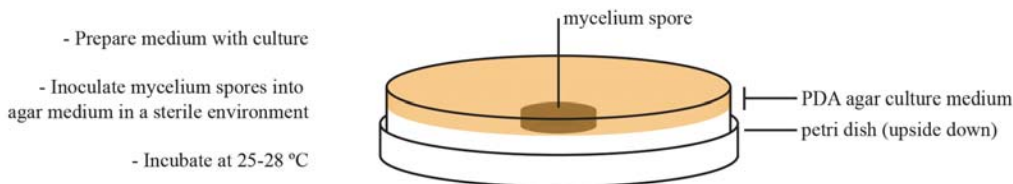

Figure 1. Set up for petri dish observations.

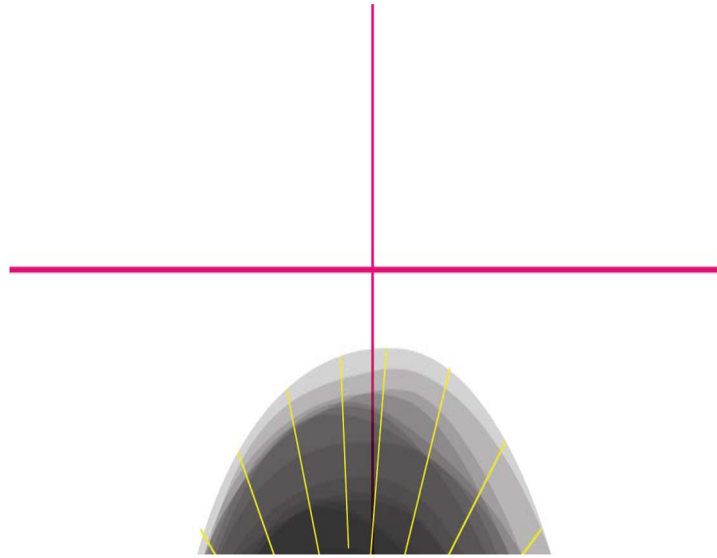

Figure 2. Radial growth pattern of mycelia in the petri dish. The direction of the growth in 17 hours after two days of growth achieved through superposing the top views which are recorded in every 2 hours.

By observing the self-organized growth of mycelia in initial experiments, we came up with the idea that MbM could have potential to act as a re-shapeable material due to its living matter ingredient, the mycelia. To examine this property of MbM, we used flexible formwork by performing physical form finding methods. Correspondingly, the setup obligates the designer to cope with constructional constraints of formwork and uneven deformation at the flexible parts of the formwork after loading the material.

Therefore, physical models are subject to constraints such as the geometry of the formwork and materials that are used to build the formwork. The feasibility, the formability and the adaptability of the formwork system play an important role in executing physical experiments.

### Constraints of the Experiments

Further to the empirical study, we developed an experiment setup based on 6-day cycles which reveal the constraints of the container which shape the fabric, material and ingredient constraints of the mycelium mixture. Therefore, it becomes possible to observe the growing process of the mycelium and follow the changes in formwork.

Although the precedents of the experiments prove that mycelia of *Pleurotus ostreatus* need 12-21 days (Url-1) to grow on a substrate during the incubation period, the experiment executed was monitored only for 6 days since there was no need to observe fully grown mycelia.

Mycelium mixture is mainly composed of substrate and mycelia spawn. To grow healthy mycelia, substrate material must be sterilised under the well-prepared conditions by placing it in boiling water for at least 120 minutes. For our experiment, a *Pleurotus ostreatus* growing kit that is composed of mycelium spawn and sawdust was used. Since it was provided from the local supplier as already inoculated, sterilisation treatment was not necessary.

The optimal growing conditions for mycelia of *Pleurotus ostreatus* defined by researchers are shown in Table 1 (Montalti, 2014; Yadav & Tripathi, 1991). The experiments we operated, however, were not held in a very well controlled and sterilized lab environment as presented in the table. We could hardly provide proper conditions. For instance, sunlight/light exposure must be prevented but during the recording processes, the experiment setup was exposed to sunlight and artificial light since a light input is essential to take photographs. Since the mycelium mixture

prepared for the experiments was not homogenous, MbM could not be placed evenly onto the stretchy fabric surface. This led to irregular loading of the mixture from the very beginning.

Humidity	90-100%
CO <sub>2</sub>	High
Light	None
O <sub>2</sub>	Necessary for growth
Temperature	23-24 °C

Table 1. Growing conditions of (*Pleurotus ostreatus*) mycelium for experiments, derived from (Montalti 2014).

The experiment setup of the formwork is developed as form-active structure so that the designer can handle its boundary conditions and topographic conditions manually. To achieve this result, elastic fabric was selected as a working material to create form-active system to implement form-finding techniques. In addition, material of the formwork is important since it provides rigidity of the system. Water-resistant, transparent and stiff materials are suitable for formwork system.

Material of the shell	Form-active structure	Form-active typology	Way to stabilise the mold	Technique to handle the rigidizing material	Reinforcement
Mycelium spawn (infected wheat grains), sawdust	Stretchy fabric (panty)	Single layer	Stretched, later on partially released	Casting	Sawdust

Table 2. Materials used in the experiment and their functions. Table is derived from ISOFF (Url-2).

### Experimentation Process

The procedure for experiment with mycelium-based material in fabric formwork is as follows:

- Installation of fabric formwork: Developing fabric mold and building frame-work
- Designing formwork structure in digital medium
- Preparing mycelium mixture
- Casting: pouring mycelium mixture into fabric mold
- Waiting for mycelium growth in mold
- Observation during growth process: form-finding applications

This general process might be applied to all fabric formwork experiments. In the light of the foregoing findings, a casting experiment is executed within the proposed methodology and constraints. Later, graphical anticipations and abstractions are derived in order to interpret material behaviour of MbM. The casting experiment is prepared as an adjustable mold in a way that designer cannot manipulate its boundary conditions from the edges but from the surface of the fabric itself. To state technically, the formwork is designed as static on X and Y axes, but dynamic on the Z axis. To build the formwork, an external frame that ensures the chosen boundary

conditions and a series of removable point supports are developed (Figure 4). The experiment setup which was executed to experiment the formation of MbM fabric formwork was pre-stressed through the combination of mechanical pre-stress of the fabric and MbM pressure. The general sequence of this method is as follows: A piece of fabric is homogeneously stretched over laser-cut plexiglass and wooden probes that are placed vertically. Then, mycelium mixture is placed onto the single layer of the fabric, full to the brim; and correspondingly, the fabric deforms with the additional load. The fabric is deformed where rod topologies primarily dictate the form with the additional load. As the time passes by, in right conditions, mycelia start to grow and expand its network.



Figure 3. Plan view of the experiment setup.

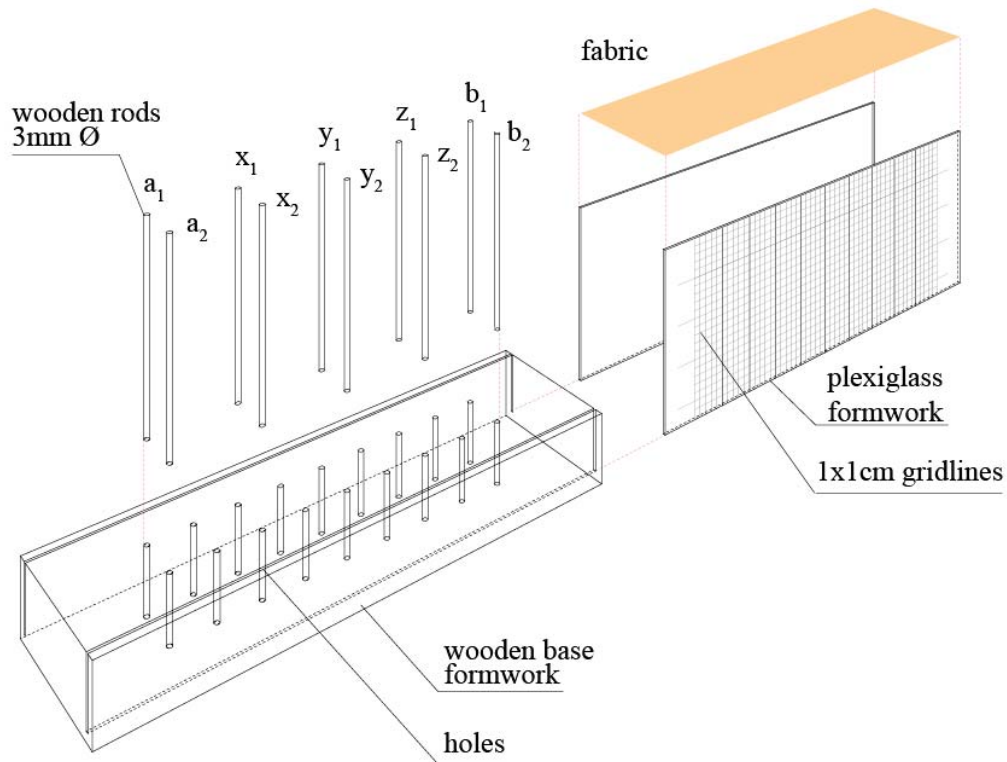

Figure 4. Point model setup



Since we had the knowledge that as more mycelia grow, the material gets hardened (this emergent behaviour of mycelia is similar to the process during which plaster solidifies through dehydration), we waited for the material to get hardened day by day.

Rods named f1, f2, f3 and f4 were stable during experimentation. Firstly, after 36 hours the mycelium mixture had been poured onto the elastic mold, this is when the first mycelia pattern becomes visible, a1 and b1 rods were detached. Then, a2 and b2 rods were removed 24 hours later. Later, a3 and b3 rods are severed 24 hours later. The fabric weakens at those points, which results in unpredictable displacement of MbM in section view. This displacement curve of the material which is recorded by the camera could display the limits of the material dependent on time constraint in search of computability of the material (Figure 5).

## Findings and Outcomes

### *Abstraction Through Anticipation*

In the case of plaster casting on fabric forming, a designer can change the form of casted plaster in the first minutes of post-pouring depending on the environmental conditions. In addition, 1 kg of plaster needs approximately 24 hours to be fully dry, thereby to be stiff. When it comes to MbM, however, since for mycelium network (the binding agent) to grow takes some time, waiting time depends on the growth rate of mycelium. Hence, the formation of MbM depends on the expansion of mycelia network in mycelium spawn-substrate mixture. To explore certain waiting time for the formation of MbM, visual diagrams are derived through predictions on formwork experiment setup.

As a starting point, according to the boundary conditions, the initial shape of MbM is described and shown in Figure 4.4 at  $t$  position. Since we are looking for the potentials of MbM, the impacts of manipulation in the formwork system which the fabric and MbM are exposed were visualised. These situations were derived in sequence, rather than establishing a target shape from the very beginning. As we remove the rods in order, the fabric releases itself and the MbM bends in the formation process. Since MbM becomes more rigid as the time passes by, lesser changes in form were expected as shown at  $2t$ ,  $3t$  and  $4t$  situations in Figure 5.

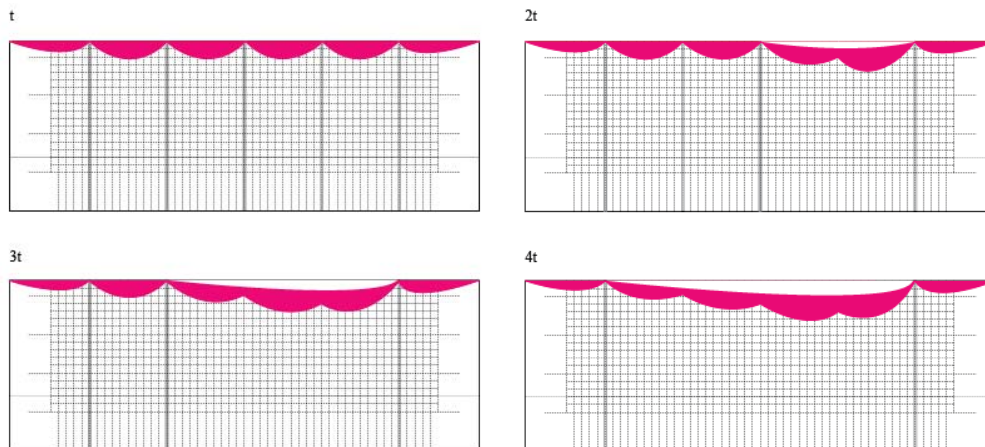

Figure 5. Predictions on the Experiment.

It is important to note that contamination challenges the consistent growth of mycelia (Figure 6). Providing an optimal growth environment is a key feature to observe mycelia network. In our

study, 23 hours after inoculation, contamination was observed but mycelia continued to grow and healed the cracks in the material (Figure 3).



Figure 6. Contamination observed at the underneath of the fabric on the 22<sup>nd</sup>, 23<sup>rd</sup>, 28<sup>th</sup>, 34<sup>th</sup> and 36<sup>th</sup> hours after inoculation.

## Visual Results: Observation

In this experiment setup, rod topologies and external frame primarily dictate form. Due to the unbalanced fluctuation of load over fabric, the first shape which the mixture and the fabric took was (Figure 7) not evenly distributed as we had predicted. As a result, the experiments displayed several irregular bending angles (Figure 8).



Figure 7. Fluctuation on the MbM shape due to irregular distribution of dead load (Initial shape).

According to our visual observation in the experiment, MbM has the ability to adapt to new forms that change in 5 days after inoculation. For dramatic changes, however, the first 2 days are the best time period.

Besides, pressurization would let MbM to shape in 7 days after inoculation during the formation of MbM. Based on the investigations on MbM, we claim that the material is suitable for reshaping. Although re-shaping can be achieved by taking advantage of material's dead load or pressurization, we aimed to reach at emergent results.

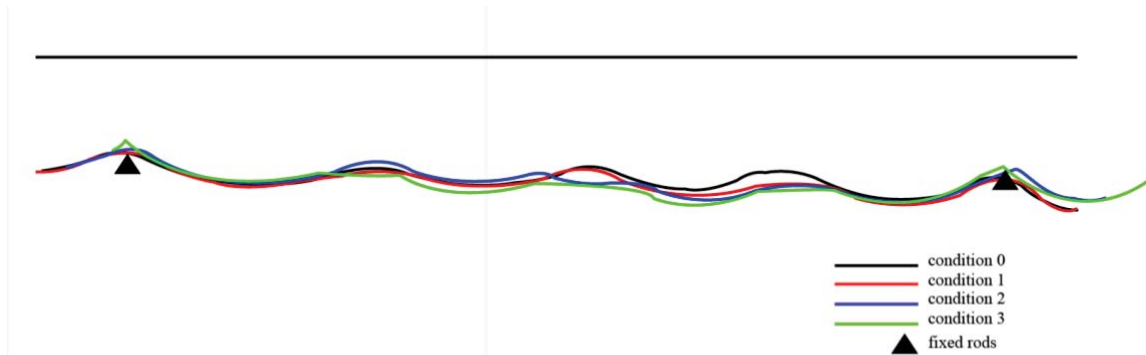

Figure 8. Superposition of the shape of MbM in four conditions based on the experiment.

## Conclusion

The realisation of design is carried out through the formalisation of materials. The methods that were applied to materialize a form are usually applied at the end of a design process. However, the study aims to obtain free-form geometric shapes through experimentation in order to examine form-taking potential of the material by focusing on the process of materialization and formation rather than trying to obtain a certain shape.

Another aim of the study was to gain better understanding on the emergence of forms which have been constituted under certain forces such as gravity and growth, and also formal operations like analogue form-finding methods. We observed that it was possible to anticipate a formation process, however it was not easy to digitalize its process precisely without informing the digital model in terms of the material selection. In particular, a dynamic formwork was constructed to investigate the reshaping capabilities of MbM.

Although resulting shapes of casted material could be foreseen, it is also possible to claim that irregularities on materialisation of MbM and elastic formwork are compelling as they reduce anticipation. At this juncture, we can mention two emergent behaviours in the experiments with MbM and elastic mold. First, formwork enhances the emergence of end shapes thanks to its elasticity. Second, imperfect mycelia network binds substrate on which it grows. Thereby, free-form geometric shapes can be constructed.

The experiments and the findings of the study can be considered as an attempt to contribute to the discussions about the novel products made up of living materials which may be alternatives to mass products. The experimentation process and results raise several controversial issues for the designer. As a result, this study provokes a new understanding in product design, architecture and building industry.

## References

[1] <http://www.agromantar.com/agromycel.html>

[2] [www.fabricforming.org](http://www.fabricforming.org)

Gramazio, F. and Kohler, M. 2008, Towards a digital materiality, in B. Kolarevic and K. Klinger (eds.), *Manufacturing Material Effects: Rethinking Design and Making in Architecture*, Routledge, 103-118.



Hensel, M., Menges, A. and Weinstock, M.: 2013, *Emergent technologies and design: towards a biological paradigm for architecture*, Routledge.

Mallick, P.K.: 2008, *Fiber-reinforced composites; Materials, Manufacturing and Design*, CRC Press.

Montalti, M.: 2014, "Interview with Lelivelt, R.J.J, Mycelium in Design". Available from [Interview] [http://alexandria.tue.nl/extra2/afstversl/bwk/Lelivelt\\_2015.pdf](http://alexandria.tue.nl/extra2/afstversl/bwk/Lelivelt_2015.pdf) (accessed 29th May\_2016).

Pink, S., Ardevol, E. and Lanzeni, D.: 2016, *Digital Materialities Design and Anthropology*, Bloomsbury Academic.

Yadav, J.S. and Tripathi, J.P.: 1991, Optimization of Cultivation and Nutrition Conditions and Substrate Pretreatment for Solid-Substrate Fermentation of Wheat Straw by *Coriolus Versicolor*, *Folia Microbiologica*, no. 3(36), 294-301.



## Growth as the Morphological Generator of Biological Identity

Ricardo Massena Gago<sup>1</sup>

<sup>1</sup>*Faculty of Architecture, University of Lisbon / CIAUD, Portugal*

<sup>1</sup>*umassena@gmail.com*

**Abstract.** The majority of the bio inspired design is focuses in the functionality of the biological shape qualities without taking into account the process that generates them. Biological shapes are generated through a growth process based on replication. This quality is responsible for a particular structural organization, which means it has a strong identity role in the shapes morphology. In order to continue to increase the morphological coherence between human and biological structures this research aims to implement this quality in human design by thinking it through a geometrical perspective. So this research starts by identifying the geometrical qualities inherent to growth. They are decoded through the development of a generative and parametric design tool (shape grammars). It allows designers to explore a process of shape generation by morphological diversity and through a biological growth perspective.

**Keywords.** *Growth; Geometry; Generative Design; Morphology; Biological Identity.*

### Introduction

In recent years the addition of digital tools allowed the implementation of biological qualities in human structures at a complexity level not seen before. The irregular and complex morphology of biological structures became easier to manipulate and replicate. Three dimensional printing and robotics also played an important role in the transposition of these design concepts into real objects. However, despite of the morphological biomimetization allowed by these tools, the majority of human structures remain without revealing a biological identity. Biological structures have the ability to be recognized in the environment whatever their shape. This happens because biological life has a morphological signature. So, if it allows their identification, it means that all have to share a common geometric pattern.

The decoding of the biological pattern is not a new subject in the ecological design field. However, this subject has been studied through a static perspective. The morphological qualities of the shape have been interpreted separately from the process that generates them. Authors like Christopher Alexander (2001) and Rudolph Arnheim (1982) argue that a quality can only be reproduced through the use of the same process that makes it emerge. So, the act of copying a shape does not carry the generative essence of it. The direct consequence of it is the loss of geometrical qualities given by the design process. This means that research lines as biomimetics are still working at a superficial level. Biomimetics were a huge step in the shape optimization field, in terms of materials efficiency and energy waste. Although with digital morphogenesis the search for the origin of biological shape went deeper. Inspired by how biological structures develop their morphology, Neri Oxman (2010) proposes a reversal idea of thinking and generating shape. In her idea, shape cannot be defined by humans. It is the matter through functional, environmental and material constrains that imposes how shape should be. This design perspective changed radically the bio inspired shapes geometry. Their morphology reveals geometrical patterns closer to the biological ones. So, this research line shows that process really matters and has an important role in the definition of shape identity. However, it is exactly in the identity subject that Alexander (2003) points out a gap in the digital morphogenesis theory. The author argues that morphogenesis



cannot be separated from growth. Alexander developed a study where tries to understand in geometric terms what biological structures have that human structures do not. So, the author identifies a set of fifteen isolated characteristics. However, he found out that the implementation of these parameters by addition is not enough to emerge this identity. Some of them are not isolated characteristics. They emerge from a process of geometrical dependence, which means that their generation result from other. The human design processes implemented are not achieving this dependence level yet. So, it is precisely because of this fact that the attempts to biomimeticize biological identity fail. According to Alexander (2001) these qualities reside in some values that the majority of biologists, ecologists and even physicists use to describe biological structures. Fritjof Capra (1982) is one of those. When the author describes biologic “mass” he empathizes the following qualities: 1) the structure is built by elements dependency, where each element is relevant to the whole and vice versa; 2) biological structures are a force transfer mass in connection with the environment and 3) the structures are in evolutive equilibrium, i.e., they evolve through shape transformation without destroying the structural composition.

Alexander also valued these qualities in his attempt to understand how the biological morphology achieves its spontaneous integration ability in the environment. According to the author, if the connection of these structures is made by force field interaction, then these qualities should also be replicated in their “physical body”. However, this quality cannot be achieved without using the design process that generates them (growth). Therefore, Alexander (2003) launched the challenge of thinking growth through a geometrical process. However, he did not develop a design method to explain how these qualities can be transferred into a geometrical tool.

So, this research aims the developing of a geometrical design process able to emerge these qualities through a biological growth perspective. The research starts by describing and characterizing the growth process and the qualities associated to it (elements dependency, evolutive equilibrium and force transfer mass). With this analysis geometrical and generative characteristics are identified. Through a decoding process using geometric and algebraic language of shape grammars a drawing tool is developed. The tool transfers the decoded qualities to human design by generating shapes diversity with the same morphological identity. Thus, it allows designers and architects to experience a design process through a growth perspective and with morphological qualities from biological identity.

## The generator of identity

The design process of biological structures is based on growth. It is with this quality that life implements its biosignature (identity) in their physical structures. Growth can be described as an expansion process through addition of elements generated by a replication process. So, it is a process of mass increase, made step by step and through shape transformation. This evolutive process is based in shape diversity. Exact copies are nonexistent. For this reason it works with a design process of infinite shape hypothesis given by the same rules, i.e., growth uses a generative and parametric design process.

The geometry imposed by growth allows achieving a shape morphology that connects so spontaneously with the environment that seems it had been always a part of it. This ability is based on the idea of collaboration and participation. Biological structures are dissipative structures (Capra, 1982). They receive, transform and return (waste) energy. So, they are a mass of force transfer (energy). However, this quality is not only a metabolic quality. It is also reflected in the shapes morphology. If so, how can it be described in geometrical terms? Biological shapes achieve it by using two distinct methods. They generate external tension in the environment and internal structural fluidity. To generate external tension the structure boundaries are built with concave or convex surfaces. These curved surfaces attract external forces into shape and invited them to flow through it by a gradient arrangement with an end point (fig.1). This point has the particularity of

highlighting the shape origin. The generator center (origin) annihilates tension but also generates it. It is this duality that gives equilibrium to a structure. The balance between opposing tensions eliminates disorder and increase shape integration.

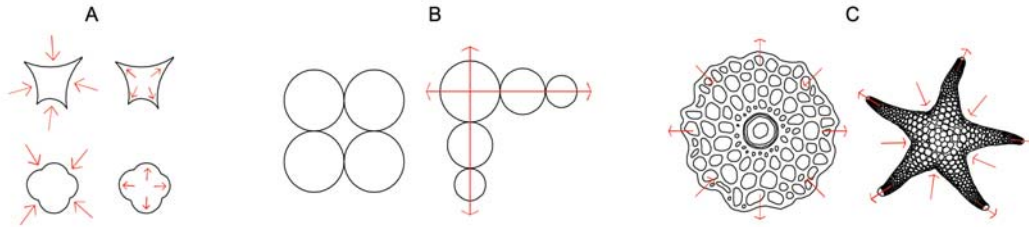

**Figure 1. Biological shape integration. Concave and convex surfaces (A). Gradient arrangement (B). Balance between opposing tensions (C).**

The generation of force field as it occurs in biological structures requires a structural organization that reveals elements dependency and evolutive equilibrium.

What means elements dependency? It is related with the geometrical balance theory described by Arnheim (1982). The author argues that to generate balance it is necessary that all structural elements reveal two distinct qualities at once. First, all the elements exist in order to emphasize a particular point of the structure and second, the elements cannot be replaced by other from the composition. Each element has to be unique and with its own rules. So to avoid elements repetition proportional variations are requiring (fig.2)

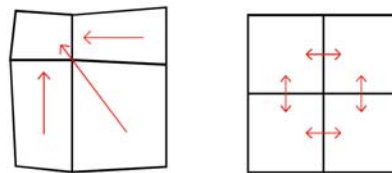

**Figure 2. Geometric balance theory. Shape with (left) and without (right) geometric balance.**

What is evolutive equilibrium? It is related with shape transformations. The changes caused by elements addition cannot interfere with the structural coherence of the whole. This requires non disturbance with the fluidity of the force field and the maintenance of all the existent composition in each transformation phase (fig.3). This quality is also crucial to maintaining the morphological identity of the structures along its expansion stages.

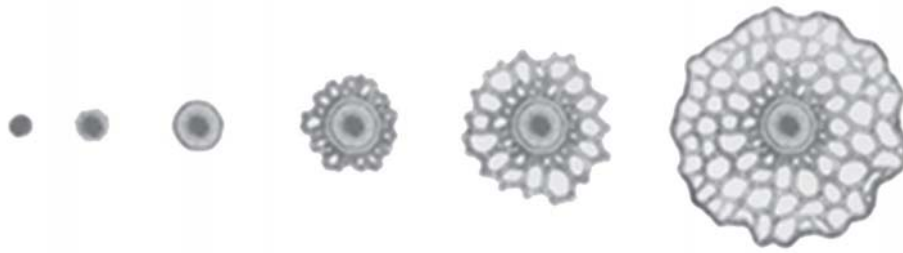

Figure 3. Shape evolution through structural balance.

## Design Process

### Drawing tools selection

As mention before, the mechanisms of biological growth are generative. They generate shape diversity through a process of rules with a short inventory (Blackwood, 2012; Pearce, 1978). So, to implement these biological qualities in human structures the development of a generative drawing tool is required.

The voronoi diagram (Aurenhammer et al, 2013) is a generative design process used in the design field due to its ability in generates textures similar to those found in biological structures. This tool is characterized by a process of spatial division referenced in a set of points located randomly in space. The possibility of adding points constantly makes its expansion infinite and allowing the generation of geometric configurations without losing structural coherence. The tool also reveals geometrical versatility. It allows achieving several geometrical configurations using the same rules. This diversity is directly related with the location of the reference points (fig.4).

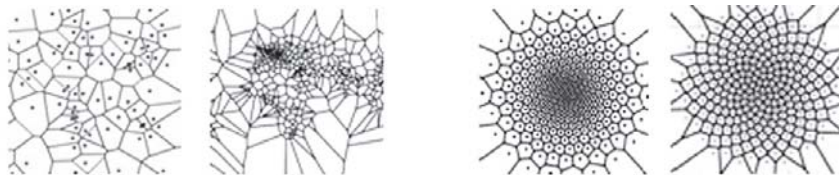

Figure 4. Voronoi diagrams tessellations. Random arrangement (left). Centroidal arrangement (right).

In biological structures, the growth mechanisms require an expansion process based on a centroidal configuration (wave and spiral) (Thompson, 1992). This configuration is crucial to generate structural fluidity by the emergence of force field. So, to voronoi diagram generates this kind of configurations their generator points need to be control for that purpose. However, the distribution and location of the referential points are not an inherent process of this drawing tool. Only the process of space division based on them it is. It means, that another drawing process is requiring to order the points disposition. For that purpose shape grammars is used (Stiny, 1980). It is a shape decoder tool using rules described through a geometrical and algebraic language. It controls all the proportions aspects and the structural relations of the geometry. So, shape grammars will be used to establish rules in order to force voronoi diagrams to achieve a certain geometrical order. However, to make it happen voronoi diagrams also have to be decoded by its language, which means that shape grammar will be the main generative tool of the design process.

## Decoding process

To generate shapes by diversity that share the same geometrical identity it is necessary to define a geometrical inventory. This should be achieved by rules described through a geometric and algebraic language. What kind of elements should be decoded in order to reach the aforementioned qualities? Five geometrical requirements should be highlighted:

1) A generator center - to point out the shape origin and simultaneously the point of non disturbance (pause) of the geometrical composition (fig.5-A);

2) A centroidal structure - arranged through a gradient pattern and referenced in the generator center (fig.5-B);

3) Shapes of triangular derivation - using the triangular design process of voronoi diagram in order to define the structural shapes boundaries (polygons) (fig.5-C);

4) Referential points - growth works through a replication process, so for that reason the referential points cannot be previously defined in the structural basis (expansion levels). Their location depends of the structural shapes geometry at each expansion level (fig.5-D).

5) Curved boundaries - the use of concave and convex surfaces in order to attract external forces into the shape (fig.5-E).

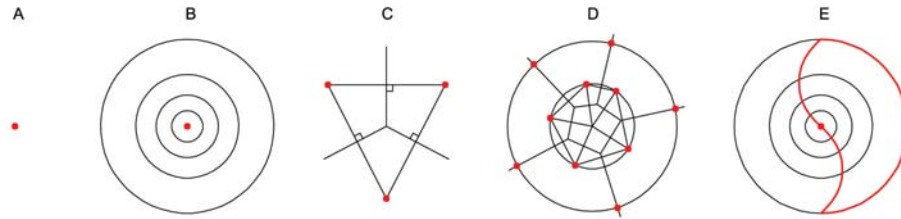

Figure 5. Geometrical inventory. Generator center (A); centroidal structure (B); shapes of triangular derivation (C); referential points (D); curved boundaries (E).

## Shape generation

The shape generation requires a generative design process divided in three steps. Each one introduces the structural basis of the following. The first defines the growth pattern through the use of an expansive shape (Thompson, 1992) referenced in a center and ordered through a gradient pattern. The gradients can be arranged through two distinct configurations, or by linear increase or by oscillation. The linear configuration reveals a clear orientation of the gradient increase. In turn, the configuration by oscillation is achieved through the addition of sub expansion levels between the main expansion levels. These have to generate a wave pattern that follows the main expansion levels pattern (fig.6). So, this stage of the design process will be responsible by the proportion ratio of the main shapes and their structural elements.

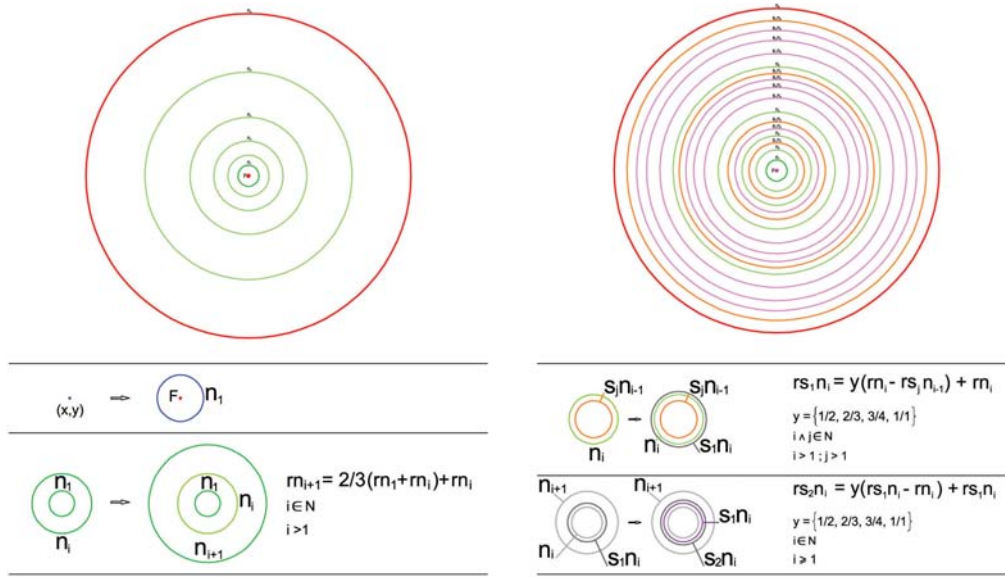

Figure 6. Structural basis definition. Rules examples.

In the second step shape boundaries are defined. Shapes generated through a centroidal pattern do not have to be rounded neither the composition center should be coincident with the geometrical center. So, the complete fulfill of the structural basis is not a requirement. The shapes proportions only should be attached to the expansion levels and organized through symmetrical requirements. Each structural basis offers several shapes boundaries possibilities and their diversity tends to increase the greater the number of expansion levels (fig.7,8)

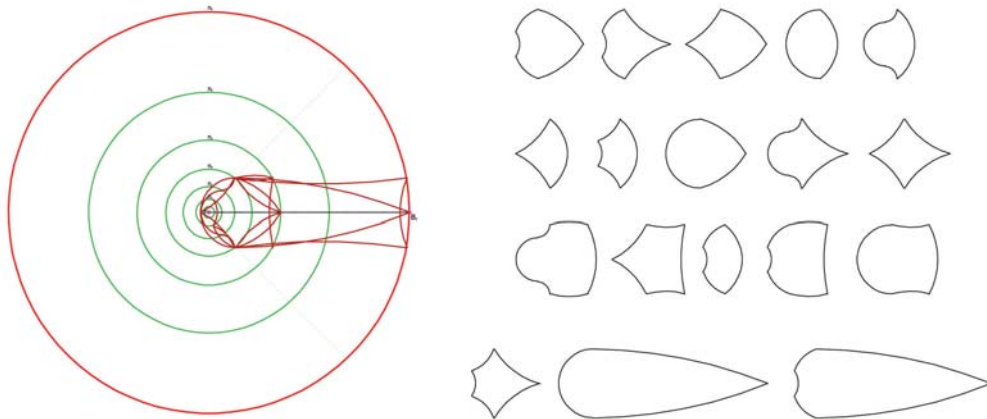

Figure 7. Shape definition. Examples of shape diversity generated through the structural basis.



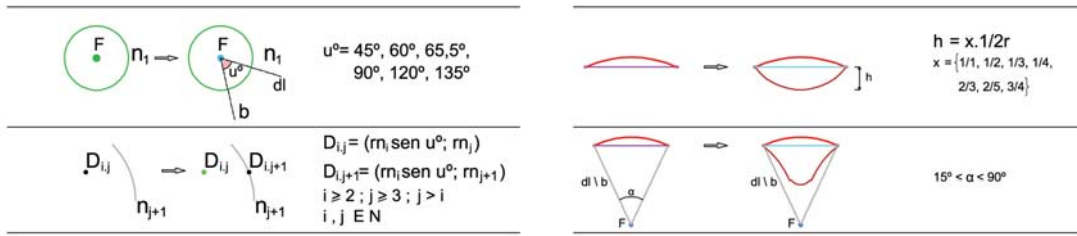

Figure 8. Shape definition. Rules examples.

Finally, to generate the structural elements of the main shape the third step is applied. These elements are implemented by rules that use the geometrical vocabulary and generation principles of voronoi diagrams. They materialize the shape according to the geometrical orders defined in the previous stages. However the shape definition is not static. It can continue to grow through the addition of new expansive levels. This ability revealed by the drawing tool allows generating shapes with evolutive equilibrium, i.e., the new shapes absorb the existing ones in their composition and without generate left over elements (fig.9).

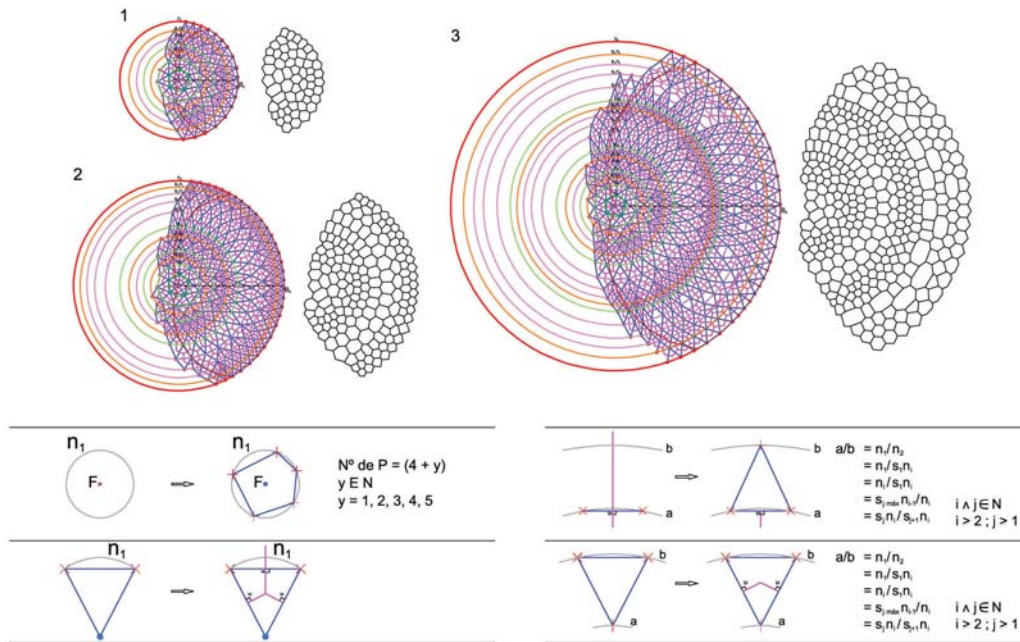

Figure 9. Shape materialization. Rules examples.

### Gradients intensification by boundaries thickness - textures

The shapes materialization with structural elements does not put an end to its design process. It is just the beginning of another "explosion" in shape diversity. With the weights algebra (Stiny, 1992) of shape grammars patterns of texture could be added. This algebra allows to work with the boundaries thickness of the structural elements. However, their arrangement should take into account the principles of fluidity imposed by growth. So, it means they have also to follow a gradient pattern (fig.10).

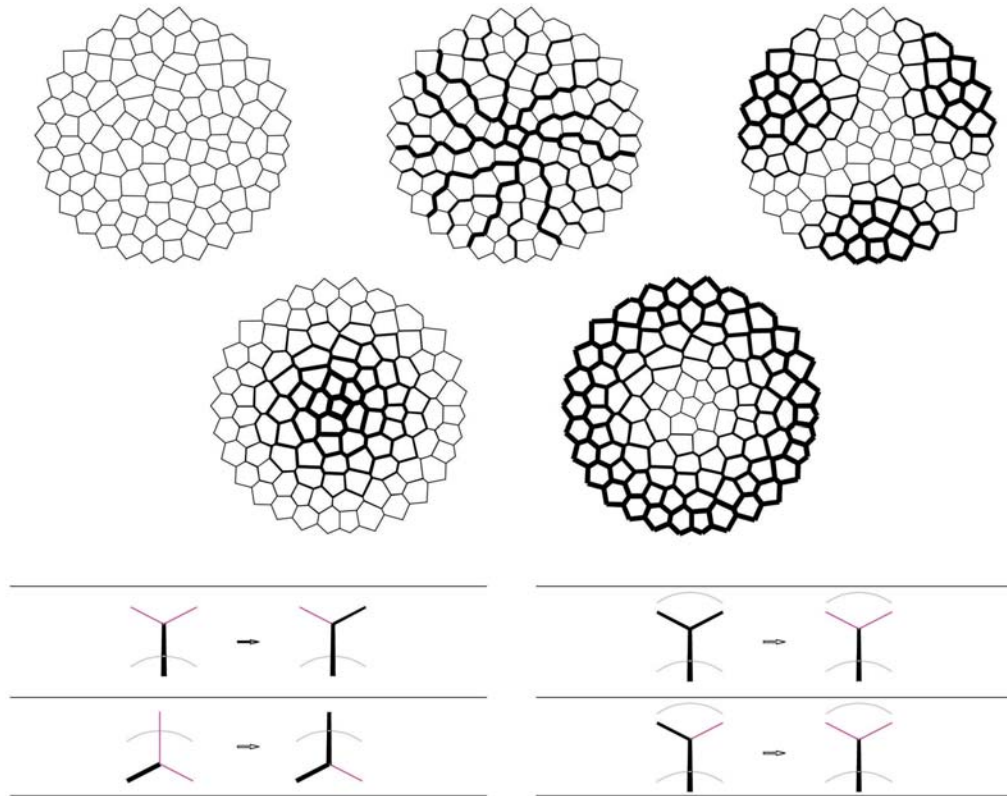

Figure 10. Gradients intensification by boundaries thickness.

## Validation

The design process developed allows achieving shape diversity with the same geometrical identity. The geometrical structures reveal elements dependency, structural fluidity and evolutive equilibrium.

The structural arrangement by following a generator center also shows to have an important role in integrating the shape in the surrounding. Irregular boundaries without a fluid internal organization are able to increase the friction between shape and surrounding, but its interior will always be separated from it (fig.11-A). In turn, a shape generated with force field appears to be more complex, but allows a clear legibility of the entire structure. The shape invites to be crossed, explaining its structure, generation and origin. So, this fluid organization does not cause any perturbation in the surrounding, which means that shape gains a participatory ability in it (fig.11-B).

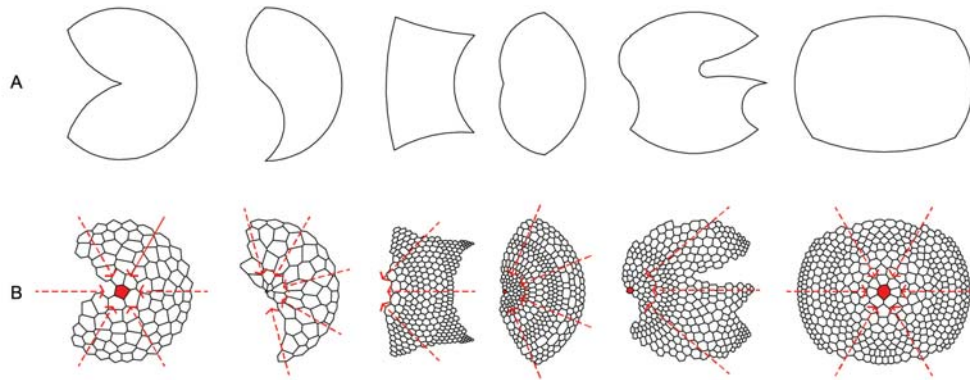

Figure 11. Integration ability. Shapes without (A) and with (B) force field.

## Conclusion

In summing, this research aims to show that the biological geometrical qualities in human structures increase their level when the design process attempts to be similar to the one which generates them. The inclusion of the growth variable is the main key to implement a strongest identity of biological morphology. Growth is the “mechanism” which allows the implementation of a set of biological geometric qualities in human structures simultaneously. Its emergence implements a specific kind of structural organization and the rules it imposes in structural elements allows to achieve qualities of the whole (elements dependency, evolutive equilibrium and force field). Growth also shows to be responsible for a strongest and spontaneous integration of shapes in the environment. The transposition of forces with the surroundings allowed by the structural organization transforms the shape morphology into a participatory structure and not as a barrier. Despite its complex geometry the structural fluidity of these shapes allows its easier interpretation and strongly affirms its origin in the surrounding.

The decoding and implementation of these principles in human structures also shows that the essence of biological geometry is not directly associated to a function. The biological shape functionality is imposed by a cognitive entity taking into account environmental and matter constrains. However the geometrical principles imposed are all the same. So the study of this geometry can generate diversified structures with this morphologic identity. However, to continue improving the integration quality of human structures into a metabolic process level others qualities than geometry need to be added. Nevertheless, the tool developed by this research allows anyone the possibility to experience spatial conception through a biological vision. It can be use in the academic field as a design tool of ecological purpose and contribute with knowledge in the bio design field. In a scientific field, it may also have a relevant role in the development of material optimization by introducing geometrical knowledge used by biological structures to achieve their ecological performances.

This research also intends to continue improving the generation process by two distinct ways. On the one hand the addition of other biological qualities which may be indentified in future researches. On the other hand, the evolution of the design process to a three dimensional tool. The development of a fabrication process able to work with biomaterials and associated to the drawing tool will be another research goal in perspective.



## References

- Alexander, Christopher, *The nature of order: An essay on the art of building and the nature of the universe, book 1 - The phenomenon of life*, The center for environmental structure, California, 2001.
- Alexander, Christopher, *The nature of order: An essay on the art of building and the nature of the universe, book 2 - The process of creating life*, The center for environmental structure, California, 2003.
- Arnheim, Rudolph, *The power of center. A study of composition in the visual arts*, University of California Press, Berkeley, 1982.
- Aurenhammer, Franz; Klein, Rolf & Lee, Der-Tsai, *Voronoi diagrams and Delaunay triangulations*, World Scientific Publishing Company, London, 2013.
- Blackwood, John, *Geometry in nature: Exploring the morphology of the natural world through projective geometry*, Floris Book, Edinburgh, 2012.
- Capra, Fritjof, *The web of life: a new scientific understanding of living systems*, Anchor Books, New York, 1982.
- Oxman, Neri, *Material-based design computation*, MIT, Massachusetts, 2010.
- Pearce, Peter, *Structure in nature is a strategy for design*, The MIT Press, Cambridge, 1978
- Stiny, George, "Introduction to shape and shape grammar", *Environmental and Planning B*, vol. 7, pp. 343–351, 1980.
- Stiny, George, "Weights", *Environmental and Planning B: Planning and design*, vol. 19, pp. 413–430, 1992.
- Thompson, D'arcy Wentworth, *On growth and form: the complete revised edition*, Dover Publications, New York, 1992.



Heliotropic Nature's  
Mary Polites, Maddalena Belle, Marida Maiorino, Raquel Paramo,  
Brandon DiFalco, Carmo Cardoso

## Heliotropic Nature's

Mary Polites<sup>1</sup>, Maddalena Belle<sup>2</sup>, Marida Maiorino<sup>3</sup>, Raquel Paramo<sup>4</sup>, Brandon DiFalco<sup>5</sup>, and Carmo Cardoso<sup>6</sup>.

<sup>1</sup>Tongji University, China. <sup>2,3,4,5,6</sup>Tongji University, China.

<sup>1</sup>BiDL@tongji.edu.cn, <sup>2</sup>maddalenabelle3@gmail.com,

<sup>3</sup>marialidiamaiorino@gmail.com, <sup>4</sup>raquel.paramo@gmail.com,

<sup>5</sup>bdifalco96@hotmail.com, <sup>6</sup>cmachadocardoso@gmail.com.

**Abstract.** Heliotropic Nature's is a research project that focuses on designing new methods of cultivation, inspired by tropisms in plants and activated by urban community engagement. The design aim is to enhance the growing capacities in densely populated cities with high levels of pollution to suggest new ways to improve the growth capacity. This approach discusses two design aspects, the physical bed design and a design for digital applications. The social aim is developed digitally, and connects the aspects of care of the garden beds to a community which is in support urban agriculture. These topics explore the larger issue of urban relationships with agriculture in the city and suggest new means of engagement and optimizing growth as a way of instantiating a relationship with food supply.

**Keywords.** *Urban Agriculture; Environmental Optimization; Interaction Design.*

## 1.0 Introduction

This paper puts forth prototypes for urban agricultural design interventions at two levels, a physical garden bed design and a digital app design which links users to the physical attributes of the garden beds. The digital explorations of these methods are represented as a series of studies which simulate the environmental conditions using Rhinoceros 3D, Grasshopper (a plugin for Rhino) and DIVA, environmental analysis software. The design scenarios explore biomimetic methods inspired by tropism in plants. This natural insight was used to inform orientation and arrangement pattern potentials for optimal angle of energy absorption, as this was found to be one of the main issues in areas with rapid population growth. The hypothesis for this work suggests that the "leaf angle largely affects the amount of solar radiation that the leaf surface receives" (Kumagai, 2014).

The project results introduce a design application which makes explicit the act of cultivation in order to engage users with the process of a tropism growing device. In turn these techniques will generate awareness of the pressures from the environment and pollution levels through interaction. The app design is meant to generate a gamification in using the beds which could extend into a larger community of common interests in urban agriculture.

The development of this work should be reviewed as a first phase conceptual series of prototypes that engage design on the two levels. In this phase the work has considered the climate and urban conditions of the context, however has yet to involve the in-depth implications and analysis of biological, ecological, or pollution impacts. The garden bed designs show the potentials of the prototype, however needed are further developments in the contextual specificity of angles to maximize exposure rates. As well with the app design, the interface has yet to consider for all of the specific details of these angles in coordination with the times of the year, species of plant and pollution levels. For consideration of this paper however, we are introducing the design concepts as the product of a cross disciplinary design approach towards urban agricultural needs.



## 2.0 Social Design Intervention - Community Based Engagement Incentives

### *The Development of the Creative Communities*

In the last decades the idea of wellbeing, implicitly defined by the modern society, can be expressed with the sentence: "more wellbeing is equivalent to more consumption and less social quality" (Meroni, 2007).

For a long time the consumption tendency has been the result of a fast and aggressive evolution that has silently brought people to waste the economic and environmental resources of our planet. Time after time, society has been lead to a certain point in which the lack of these resources, paradoxically switch individuals' needs toward the aim for a sustainable way of living. Currently, due to increased awareness and transparency of information, consumers are developing responsible behaviors and conscientious lifestyles, which in turn establish new patterns of habit. As part of the nature of such habits, a bottom-up distribution of knowledge has taken root and shifted the patterns of everyday life at the community level.

This work focuses on these aspects as the main social activators for the project. Firstly, with the ability to generate awareness of lifestyle through the development of responsible behaviors made visible through user involvement. Secondly, that the people involved are a creative community that can work towards a collective wellbeing. This type of instantiation within the community is of necessary to develop an effective urban agriculture at the city-wide scale as there needs to be a sense of participation and distribution.

## 3.0 Context

### *3.1 Shanghai China*

The positioning of this research is set in the urban context of Shanghai China. Currently, in Shanghai and across China, India and Africa, the population growth is expected to continue growing at rapid rates and become the world's dominating populations by 2050 (United Nations, 2015). In addition to this, it is anticipated that many of these populations will be living within an urban context by then end of this century. More than 50% of the world now exists within cities and this is expected to continue by 2050 to be about 66% of the global population (United Nations, 2014). This concentration towards urbanity introduces issues related to the environment due to increasing demand of basic needs. Two of these central pressures are expected to come from agricultural production and distribution as well as energy supply. To address these rising concerns, the work explores how these environmental pressures can be made explicit at a local level of the individual to increase awareness and relationships with urban cultivation techniques. The project site is at the Tongji College of Design & Innovation in Shanghai China.

### *3.2 Agriculture in China*

The environmental pressures associated with current energy supply within China, stem from factories where the burning of coal to produce energy is the most accessible means of supply. In the context of China, air quality indicators measuring pm 2.5 and pm 10 have increased the transparency of levels known to the public, and as such there are raising concerns coming from an increasing population and their health. However, less studied or less transparent are the effects of pollution on agriculture and the systemic effects on growth of plants, their life spans, their levels of nutrient value and their vitality against disease. With the rising amount of population and the



concern that food security is one of the primary issues facing the rising population, innovative measures to increase supply could become future solutions.

Urban Agriculture has been prevalent in Shanghai for years, as it has been a policy target for the city to remain self-sufficient in cereal production and supply 90 percent of its vegetable consumption needs [1]. In recent years, much of Shanghai's peri-urban land has been dedicated to agriculture. Currently, tens of thousands of hectares on the outskirts of Shanghai are intensely cultivated with a great deal of vegetables (Cai, 2011). Despite these goals set by the municipal government, regions throughout China, including Shanghai, have been suffering decreases in the availability of arable land due to rapid urbanization. In 2011 the Minhang district of Shanghai, peri-urban agricultural plots had been reduced to just 5,000 hectares, accounting 13.5 percent of the district's land area (Norse, 2015).

At a regional level, the entire eastern region of China has a loss at 18,542 km<sup>2</sup> or 1.2% of its total agricultural land area (Shi, 2016 & Lu 2013). While the percentage of land dedicated to agriculture decreases, Shanghai's population has been steadily rising, with an average population growth of 15% each year (Cai, 2011). This decline in arable land and steady increase in population size has caused China's food security to become heavily dependent on the intensification of production (Padhi, 2013).

As the current practices do not lead to a sustainable pattern of life from either the producer or at the consumer level, another means must be explored to compensate for the projected future. To begin this exploration, the project considers the mass of the population as an asset. Along this concept, patterns of decentralizing food cultivation were explored as a distributed system of gardening plots for city-wide agriculture has yet to be considered as a main source of production. To address the pressures of rising pollution impacts, the study focuses specifically on the formal relationships between plants and growth.

### ***3.3 Biomimetic Design & Tropism in Plants***

Biomimetic design is a practice that looks at the systems of nature and abstracts core relationships from these associations. In this research, a project driven approach towards design was explored, which means that the end aim was defined and then a natural organism was sourced for inspiration. The design intent was to develop a passive solution to improve the growing capacity of plants within heavy air pollution. As mentioned above, the main means of improving growth were defined as increasing the photosynthetic rate of plants, to counter the effects of pollution. From this insight, heliotropic and phototropic plants were looked at as potential solutions for growing beds. After further study of the plants, the mechanisms which allowed for solar tracking provided a stationary solution to increase exposure. The activation of the plants movement was found to be due to the release of auxins, a chemical in the cells of the stems or of the leaves, which would alter the turgor pressure and generate cell differentiation which would lead to change in the formal angle. Continued research of heliotropes showed that not all plants possess the ability to orient to the sun. The plants that do orient may increase plant photosynthesis by increasing the contribution made by young leaves, which are photosynthetically more efficient than older leaves" (Wang, 2015).

This orientation of young leaves has been suggested to be related to the need of pollinator attraction which is driven by heat (Atamian, 2016). Therefore, design studies were explored to optimize orientation and arrangement towards solar exposure to increase levels of photosynthesis and heat to attract pollinators.

### ***3.4 Solar Tracking Devices***

Dynamic Solar Tracking devices exist throughout the solar industry and have been implemented in a range of designs from the Solar Power Tower in Seville Spain, to commercial industries such as Solar Tracking Systems power by LINAK, to more unique design approaches such as the dynamic



Kirigami structures for integrated solar tracking (Lamoureux, 2015). Generally, these systems employ a system which comprises of a mechanism which allows for movement and solar cell collector from a surface oriented towards the sun in order to absorb the most exposure. Taking these principle concepts into consideration, the movement mechanism was the first design which needed development. As found in other case studies, the movement of devices is typically in a range from 180 degrees in all directions and with a head that can allow for two directions of articulation.

As the design was meant to be a device which would promote wellbeing and a sustainable lifestyle, generating a design which would not require additional energetic input was a main constraint. Therefore, the energy was decided to come from the activation of a system from users, or put in another way, human generated interactions. Additionally, the device for the rotation was meant to be accessible so that re-creation of the beds would be possible. For the first prototypes of the design, the device was a carjack, which would be rotated with a crank. Later refinements were added that allow for a notching system to hold the bed on one side, while the jack could be rotated in the other direction, allowing for two angles to be articulated.

### **3.5 Arrangement & Orientation**

The main objectives were that of solar absorption and heat gain through bed adjustment. An additional constraint was added once the beds were mocked up. If the beds were aligned along an orthogonal grid, the shadow of each bed would eventually cast upon the adjacent beds. Therefore, to consider adjacencies in shading, further review of packing patterns were explored in which sun was optimized in the arrangement.

From this research, the Sunflower was again an organism used as reference as the seed alignment and packing was set along a spiral phyllotaxis pattern. This pattern in the case of the Sun Flower, *Helianthus*, was found to "form two oppositely directed spirals: 55 of them clockwise and 34 counterclockwise [3]. This pattern is one of optimization for flower petals, leaves, stems etc in plants, as it allows for a minimum amount of shadow from one element to another [2]. With this insight, the packing pattern of the garden beds followed that of a spiral phyllotaxis as seen in [FIGURE 2].

## **4.0 Tropic Nature's Proposal**

### **4.1 Methods & Materials**

The designs were developed through a series of prototypes that were explored through physical and digital testing. The first designs considered a full packing of the garden beds, as shown in [FIGURE 2]., however due to use and planting space, the second design allowed for room for users to pass along the sides of the bed, as shown in [FIGURE 1]. The size of the beds and the depths, developed from up-cycled wooden pallets from the university students. These pallets were deconstructed, cut down and developed into modules that allowed for a minimum depth of 15 centimeters. The sizes were developed into sizes that would consistently be less than 60 centimeters, to allow for ease of angle adjustment and controlled weight of soil.

## 4.2 Results



Figure 1. Heliotropic Prototype Design - Shown in the image is a concept rendering of the agricultural prototype arrangement for a roof top garden.

Formally, heliotropism modifies daily changes in the mutual shading of leaves and reduces the mean angle between the blade and the sun beam, increasing leaf irradiance" (Shell, 1976). Conceptually, design that address the sun radiation throughout the day could begin to compensate for higher levels of exposure and absorption associated with photosynthesis. While at the same time, through controlled packing patterns, minimal adjacent shadows can be maintained to optimize exposed areas [FIGURE 4]. The simulation in [FIGURE 3] begins to express instances of higher sun concentration on the garden beds if uniform inclination was executed.



Figure 2. Conceptual Movements - Heliotropic Prototype Design) Renderings showing design of the prototypes movements throughout the day, from a horizontal position on the left, towards a shaded vertical condition on the right. Shown above are unified movements to convey the angle change. Actual suggested movements would be based on local indicators and individual rotations of beds.



Figure 3. Solar Radiation and rotation) Rendering series showing simulated exposure and surface rotation from a horizontal bed to a vertical position.



Figure 4. Shadow Impact - These images show the level of impact from shadows based on the orientation of the surfaces. The white is the shadow coverage. On the far left are the shadows from a horizontal position suggesting a summer condition with high sun exposure, on the right are the shadows shown from a vertical position suggesting either a cooling condition or optimizing for low winter sun exposure.

Each of the images above depicts a stage in of rotation the beds could achieve. The models explored rotation along two axes to most closely simulate that of a heliotropism. From the research conducted, it appeared that a perpendicular angle to the sun throughout the day allows for the highest possible energy absorption. Therefore, depending on the season and climate conditions, the beds would have to adjust from a vertical condition in the winter to address low sun angle and very high angles with a flat condition in the summer.

## 5.0 Community Engagement

The integration of this project relies on the community involvement which is based on the ordinary person. Typically, it would seem unexpected to consider an ordinary person able to generate creative solutions, but if this person is afforded the chance to express themselves and the provided the proper guides to discuss their everyday experiences and insights, the results could be surprising. People, with their different personalities and points of view, can quickly become the “heroes” and the makers of the path toward sustainability when provided the methods to express themselves. The understanding of the community’s creative insights and the ability to address these insights toward a collective wellbeing vision has brought on the creation of the “Creative Community”.

Along this line of thought, the main creative community that is intended for the garden beds will be founded through interactions and shared knowledge. Starting with those that are purely





curious about how the environment could be improved, and extended into an audience that generates their own community from these interests.

### **5.1 The APP Interface**

The concept for the app, Heliobox, is that it provides an interface that through touch points, sensors and senses of community generated through a platform of connected users, people can become informed on the needs of the planting beds and actively take part. The beds are in-turn rotated, inclined, watered etc., based off of the actions of engagement, informed by the app. The relationships are reciprocal in that, the beds cannot develop to their full potential without the users, and the users will not know how to operate the beds without the transparency offered through the app.

### **5.2 The Garden Bed App Introduction**

The first engagement of the user is through a series of touch points to lead them through the instructions of the first touch point to the end user profile and operating of the app. These guides will be located physically next to the garden bed arrangement for ease of access to new users. The series of guides will cover from the instructional totem, to the app, and finally how to navigate user profiles in understanding the beds information.

**The totem,** a PVC banner is used as the first indicator to welcome and give basic service information to the new users. From a QR code, a link will be made accessible for download of the service app and then users are directed to join the community.

**Heliobox app.** Every new user greeted and instructed on how to create their profile. From these profiles, each user will learn about the garden care, and will be "awarded" with a symbolic score according to their involvement.

**The Garden Beds.** Each plant bed will have a navigator mark to easily indicate the orientation direction through the app. While, to understand the right inclination, the four sides of the bed will have different colors to associate clearly which side should be adjusted. These graphics are represented in [FIGURE 5].



**ROOFTOP GARDENS**  
 PLAN AND TOUCHPOINTS

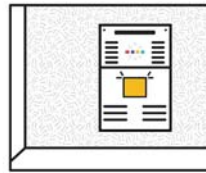
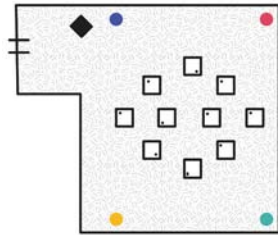

**THE TOTEM**  
 PVC banner to welcome and give basic service information to the new users.  
 From a QR code it will be possible to download the service app and join the community.



**THE APP**  
 Every new user by creating its profile will learn about the garden care and he will be "awarded" with a symbolic score according to his work.  
 The app will provide general and detailed information about each plant bed.

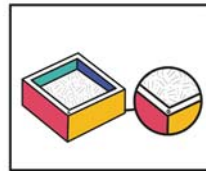

**THE PLANT BEDS**  
 Each plant bed will have a navigator mark in order to easily indicate the orientation direction through the app.  
 While, in order to understand the right inclination, the four sides of the bed will have different colors.

Figure 5. Plan & Touch Point, the App, Plant bed information - The image on the left shows the potential layout of user touch points for information on how to use and engage with the beds. These images on the right show the user experience to access the garden system.

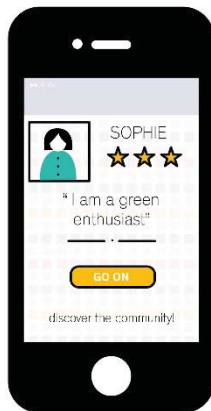

**CREATE YOUR PROFILE AND INTRODUCE YOURSELF TO THE COMMUNITY**

(a)

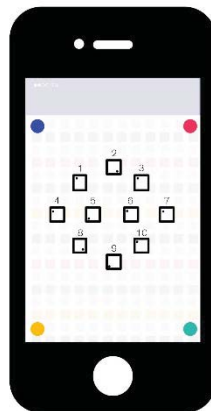

**OVERVIEW OF THE GARDEN PLAN**

(b)



**DETAILED INFORMATION FOR EACH PLOT**

(c)

Figure 6. Plan & Touch Points - These are images showing the user experience to access the garden system through the app interface

**5.3 Heliobox Interface**

Inside of the app, the generation of each users profile will allow for you introduce yourself to the community. By inserted your nickname, a picture and a small description of yourself, a personal



Heliobox profile is created by indicating your interests, such as "Green enthusiast!" "I love to eat vegetables", your personal agenda can be made visible throughout the network.

Thanks to the navigator present on each plant bed and the four colored orientation points will be possible to understand the right rotations of all the boxes. [FIGURE 7], (b) Detailed information for each plot as shown in [FIGURE 7], (c) will be expressed through infographics and instructions. By selecting each plant bed, the user will discover its current status and care information such as which seeds have to be planted; when to harvest; water, inclination and rotation that the plot needs.

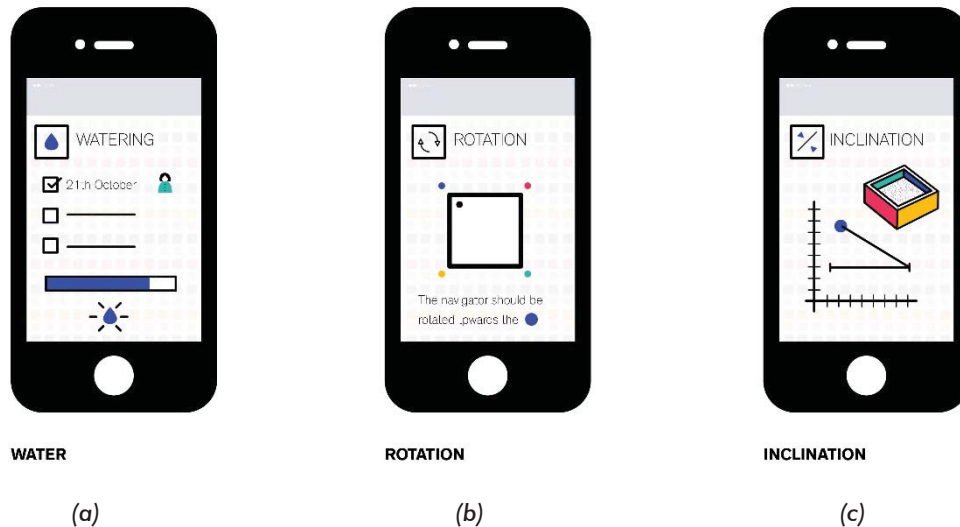

Figure 7. The APP - These are images showing the user experience to access the garden system through the app interface.

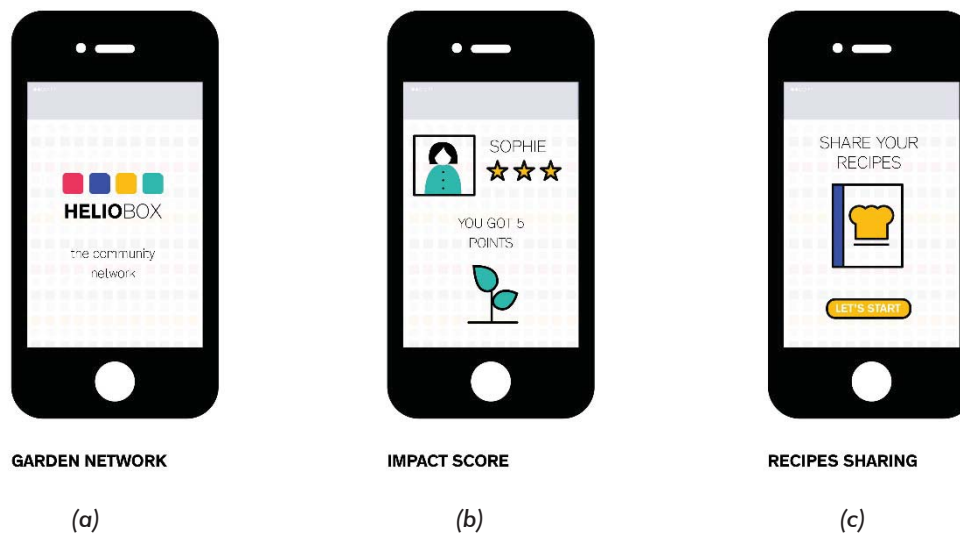

Figure 8. The APP - These are images showing the garden network, take-care-points and shared recipes through the app interface.



## 5.4 The Garden Network

The benefit of a digital online presence is not only in detailed levels of specificity regarding the current conditions related to the plants, but the genesis of an online community. Through the app, the users will be able to chat, exchange advice and suggestions about the garden plants in addition to becoming friends and an extensive network.

In order to increase traction within the community, each profile will have an impact score, to provide a sense of gamification and acknowledgement for efforts. The users will be symbolically awarded with a “take care rating” which according to their efforts will increase their score. Finally, through recipe sharing within the network users will have an accessible means to generate their own inputs from the products of the garden. Additionally, these recipes will allow for an increased awareness against monoculture crops through explanation of harvesting of only planted vegetables from within the correct season. This would enforce the community relationships through sharing, awareness, and ideally inputs and increased profile interactions.

Through various levels of involvement and connection, users of the garden system can begin to generate a local presence which can develop into a larger network. The intention is to create a platform that is linked to the context of the place from the environmental aspects as well as the social and urban conditions of the community.

## 6.0 Conclusions

Heliotropic Nature's and Heliobox provide prototype solutions which explore an interdisciplinary approach to agricultural design within the city. As a means forward, this design could be compared to current standards for rooftop farming in cities, vertical gardening and also hydroponics as alternative methods for cultivation. The design results suggest that through this combinatory method, new patterns for growing arrangements may be possible in an urban environment.

As this work is meant to be an initial phase of conceptual exploration the potential developments of the next phase can now be outlined. In the second iteration of the work, the focus will be on how to distribute information which could act as the testing phase of the design. By including a downloadable instructable online for a how-to users guide, individuals could build their own beds, and develop their own analog app guides, to inform orientation. Through accessible social platforms such as Instagram, Twitter or a simple website design, the online community can take shape even before full development of the app is made possible. The aim for this analog development is to test the main user base within cities and see where interests and long term users would like to engage. The main aim of these developments is to be a catalyst for a larger initiation of a community based gardening within China in order to bring increased awareness of the environment through engagement.

## References

United Nations, Department of Economic and Social Affairs, Population Division, *World Population Prospects: The 2015 Revision, Key Findings and Advance Tables*, Working Paper No. ESA/P/WP.241, 2015.

United Nations, Department of Economic and Social Affairs, *2014 revision of the World Urbanization Prospects*, Report, 2014.

Meroni, A., & Bala, P., *Creative communities: people inventing sustainable ways of living*. Milano: Poli. Design 2007.



Atamian, H. S.; Creux, N. M.; Brown, E. A.; Garner, A. G. Blackman, B. K. Harmer, S. L., "Circadian regulation of sunflower heliotropism, floral orientation, and pollinator visits", 353 (6299), 587-590, *Science* 2016.

Cai, J.M, Yang, Z.S, Liu, S.H, Guo, H, and Du, S.S. , "Urban Agriculture development in Minhang, Shanghai", 25:60-62, *Urban Agriculture Magazine* 2011.

Kumagai, E., et al., "Dorsoventral Asymmetry of Photosynthesis and Photoinhibition in Flag Leaves of Two Rice Cultivars that Differ in Nitrogen Response and Leaf Angle". *Physiologia Plantarum*, 151, 533–543. doi:10.1111/ppl.12145. PubMed 2014.

Lamoureux, A., Lee, K., Shlian, M., Forrest, S.R., Shtein, M., "Dynamic kirigami structures for integrated solar tracking", 6, 8092, *Nature Communications* 2015.

Lu Y., Chadwick D., D. Norse, D. Powlson, and W. Shi, "Sustainable intensification of China's agriculture: the key role of nutrient management and climate change mitigation and adaptation," *Agriculture, Ecosystems & Environment*, vol. 209, pp. 1–4, Nov. 2015.

Norse D., Ju X., "Environmental costs of China's food security," *Agriculture, Ecosystems & Environment*, vol. 209, pp. 5–14, Nov. 2015.

Padhi, S.K, Dash, M, Sawin S.C., "Effect of sulphur dioxide on growth, chlorophyll and Sulphur contents of tomato (*Solanum Lycopersicum L.*)", 9(36):465, *European Scientific Journal* 2013.

Shell G.S.G, Lang R.G., "Movements of sunflower leaves over a 24-h period", 16:161-170, *Agricultural Meteorology* 1976.

Shi K., et al., "Urban Expansion and Agricultural Land Loss in China: A Multiscale Perspective," *Sustainability*, vol. 8, no. 8, p. 790, Aug. 2016.

Wang, W., Guo, L., Li, Y. et al., "Greenhouse gas intensity of three main crops and implications for low-carbon agriculture in China", 128: 57, *Climatic Change* 2015.

[1] Girardet, H. (2014, November 05). "Making cities sustainable with urban agriculture", Retrieved May 02, 2017, from [http://www.theecologist.org/green\\_green\\_living/2623495/making\\_cities\\_sustainable\\_with\\_urban\\_agriculture.html](http://www.theecologist.org/green_green_living/2623495/making_cities_sustainable_with_urban_agriculture.html)

[2] Tennant, D., Byrd, D., "Scientists look to sunflowers for solar panel design", Retrieved May 02, 2017, from <http://earthsky.org/human-world/scientists-look-to-sunflowers-for-solar-panel-design>

[3] Weisstein, E. W., "Wolfram MathWorld: The Web's Most Extensive Mathematics Resource." [Online]. Available: <http://mathworld.wolfram.com/>. [Accessed: 02-May-2017].



## Design as an adaptive time-scape

Susannah Dickinson

*University of Arizona, Tucson, AZ, USA*

*srd@email.arizona.edu*

**Abstract.** Concepts of emergence and adaptation are ubiquitous in biological complex systems, whose dynamics interact in non-linear ways. How can the design of the built environment, from material selection to the design of cities, take advantage of this knowledge to promote more sustainable futures?

This paper will present the connections between complexity theory, new materialism and biomimetics through the dissemination of work from an undergraduate level design studio, where computational design methodologies were synthesized with these theories.

**Keywords.** *Design; Adaptation; Pedagogy; Theory; Biomimetics*

## Background

Architecture and urban design, historically, have had a very important relationship with the natural environment for many reasons, a primary one being that all materials and sites originate from the earth. Vincent Scully (1991), Sterling Professor Emeritus of the History of Art in Architecture at Yale University, has written: "But underneath all the complexity of those urban situations the larger reality still exists: the fact of nature, and of humanity's response to the challenge – the threat, the opportunity – that nature seems to offer in any given place. It follows, therefore, that the first fact of architecture is the topography of the place and the way humans respond to it with their own constructed forms. Do they attempt, for example, to echo the shapes of the landscape or to contrast with them? In a rather too large a generalization, it might be said that all pre-Greek or non-Greek cultures chose the first alternative and the Greeks more or less invented the second."

This "contrast" or one could argue, detachment of nature, became almost synonymous with "civilized" society and culminated in the Modern Movement of the early twentieth century, when a machine-age aesthetic became the goal of many architects. The term "International Style," was coined in an exhibit at the Museum of Modern Art, in New York City, 1932; form followed function, but was apparently mainly devoid of environmental or regional constraints. Advances in air-conditioning and other technological advancements separated humans further from the natural environment and also attempted to control nature into a simpler, manageable system. This in part has led to our current environmental crisis.

Richard Sennett in his essay on the Open City [1], speaks of the need for porous borders and membranes verses simplified boundaries and walls.

Today, the natural versus the human-built environment is becoming less defined; there is nowhere in the world which has not been altered in some way by humans, which has led to the proposed Anthropocene era. Without getting into the effects of climate change, the relationship of the built environment to nature is a matter of degree, with wilderness areas as the least disturbed and large urban cities typically at the other end of the scale. The emergence of the computer in our global information age potentially marks another sense of our detachment from nature. Everything is now packaged so professionally and invisibly that more and more people buy the image that everything is okay. Earlier, the signs of pollution with big business were more obvious; now this happens on a more subtle (invisible) level or often away from many of our direct, geographical view.



However there is no sense in being nostalgic about the past or becoming a Luddite in this technological age. So how do we move forward? Apart from valuing nature and other forms of life for their own sake, many people are espousing a more ecological framework as a solution to these issues of increasing urbanization, using nature as a design model. This would involve seeing the city as a complex, natural system, a “live” metabolic system containing flows and feedback loops, inter-connected in a holistic way, specific to their time and place, with short and long term implications.

The challenge is to look at this issue holistically, but not as unified or in equilibrium in a conventional sense. Modernism left us some of the worst urban conditions today. These were often designed with a heavy top-down approach that tried to control the built environment, leaving no room for human or natural self-expression, agency and/or adaptation. Aldo Leopold (1949) suggested: “too much safety seems to yield only danger in the long run. Perhaps this is behind Thoreau’s dictum: In wildness is the salvation of the world. Perhaps this is the hidden meaning in the howl of the wolf, long known among mountains, but seldom perceived among men.”

The challenge of the design work was then, how do we design with a more bottom-up approach that incorporates a level of “wildness”, which would bring life into the built environment? Aiming at a more humane outcome with a more posthuman focus.

## Nature as a model

Looking to nature for inspiration is not a new concept. In the past individual architects have related to the natural environment in many ways. Frank Lloyd Wright’s views on the organic were comprehensive, ranging from a piece of furniture in his “free” plan to the design of cities. He stated that, “All genuinely great building is transitional building ... always to have sufficient reflex to accommodate inevitable organic change. In other words it is not ‘classic’ it is organic.”(Sergeant, 1976)

We may not need a built environment that is actually alive, (although depending on how one interprets new materialism then it may be thought of as so), but as complex organisms inhabiting these places, we need a level of complexity and flexibility to remain interested, adaptable and alive within it.

Jane Jacobs (1961) in her landmark book of the sixties, *The Death and Life of the Great American Cities*, conveyed an image of the city as a vital organism, alive like nature, capable of adaptive change. She studied the “ecology of cities,” comparing the ecosystems created by nature to those created by human beings: “Both types of ecosystems - assuming they are not barren - require much diversity to sustain themselves. In both cases, the diversity develops organically over time, and the varied components are interdependent in complex ways. The more niches for diversity of life and livelihoods in either kind of ecosystem, the greater its carrying capacity for life. In both types of ecosystems, many small and obscure components – easily overlooked by superficial observation - can be vital to the whole, far out of proportion to their own tininess of scale or aggregate quantities.”

Although seeing the built environment as an ecosystem seems to be a positive direction to take, it is important to note that our built environment is currently not as complex and diverse as the natural world, with regards to its buildings, organization and infrastructure. There are several ideas that enable us to rethink our attitude towards design, e.g. biomimetics, complexity theory and new materialism. They originate from different areas of the academy; the design-fields, science and philosophy respectively, but all are related in their desire to study and/or relate to nature in some way. All of these have a proven track record, per se, but without the larger contextual relationships and ethical ideas, they have the potential to facilitate isolated, closed, superficial design processes which are not that different from business as usual, rather than incorporating the more bottom-up, dynamic qualities of nature. How can we use this knowledge, to really promote more sustainable



futures, in a non-anthropocentric way? Factoring in more relevant variables and parameters is part of the equation; understanding the true costs and connections of what we do on a socio, economic and environmental level is a start. Even if we cannot measure or factor in everything, we need to start by incorporating more and not oversimplifying, realizing how dynamic, interconnected and organized everything is. Like William McDonough's adage, is being less bad good enough, what we need is a new language (2017)[2]

## Pedagogy

An upper level, semester-long, undergraduate design studio at the University of Arizona sought to introduce students to these concepts for the first time. Prior to this class, students had been exposed to a fairly traditional architectural background where in each studio they were given a program and site for a proposed building. Even though they were aware of performative design and issues of sustainability, they had not looked at any of the theories related to this paper. The studio, pedagogically, sought to leave the final 'product' more open and ambiguous than previous more prescribed classes, so individual students would have more control of their design proposals and hopefully have more time to explore the theoretical implications. Like architectural practice, sometimes the academy can get too focused on making and doing (production), verses asking why, how and what.

As a first step it was important to give some direction and get students exposed to these "new" ideas and to others work in this area. As the studio was an undergraduate level, fairly rudimentary course, initially readings were selected based on a tier system, with required, primary sources from each particular theory selected for their clarity and brevity. During this initial assignment it was not enough for students to read in a passive sense, but it was and is essential for design students to do, to be active. As designers this means creating something, digitally or physically that is a dissemination of some kind, in this case it was related to these theories, concepts or ideas. This creative process helped solidify concepts and becomes an iterative feedback loop, which can aid in the design process. Some students tried to diagram what the theories were and/or their relationship to each other, whereas others latched on to a particular aspect or attempted to reflect on what these ideas meant to a design process that is more connected to its environment (Figure 1). It was also an opportunity to try out simple design exercises based on these principles, one student, Derek Roadcap, set up a series of self-developing drawing experiments where the catalyst was a line projecting at a fixed angle from the corner of the page, when it hit the boundary it would reflect tangentially. In the example illustrated (Figure 2) one can see how the form becomes more complex by just by shifting the boundary edge slightly. This became a very simple, effective way of visualizing complexity; getting complex results from very simple parts/rules. The images, though static moments in time also gave a sense of dynamism and imply an iterative process.

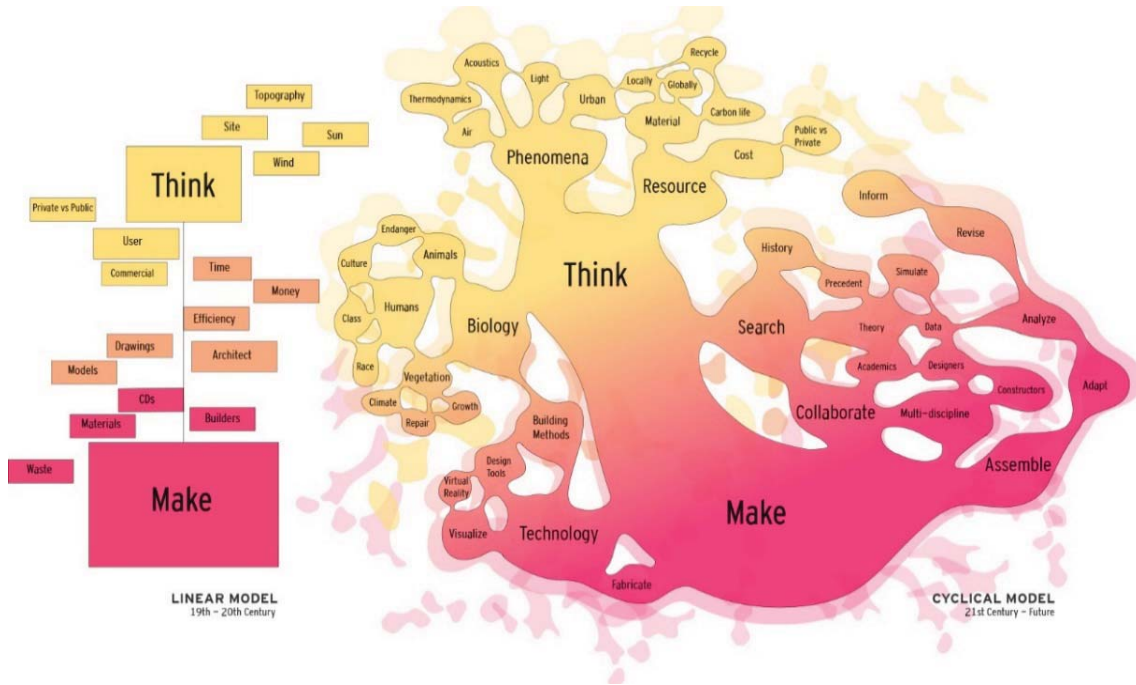

Figure 1. Design model in the new age, showing older more linear, vs. cyclical model, which has a relationship with its environment (background) (source: Di Ngo Le, B.Arch graduate 2018)

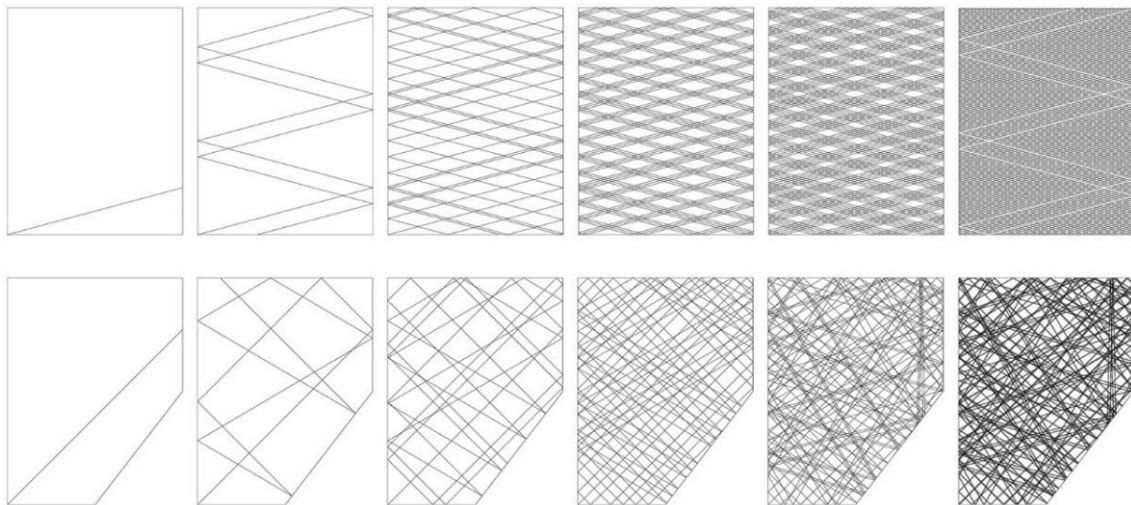

Figure 2. Complexity from simple rules and changing boundary on lower line (source: Derek Roadcap, B.Arch graduate 2018)

Additional optional, secondary readings were made available, which included related theorists/designers who are attempting to incorporate these ideas into their scholarly and/or design work. Two of these essays that students particularly connected with were the work on "Open Cities" by Richard Sennett (Figure 3) and a recently published essay by Alejandro Zaera-Polo (2017) on the "Posthuman City", where he argues for "new urban cosmologies and an embracing of technology to enhance the democracy of urbanism".

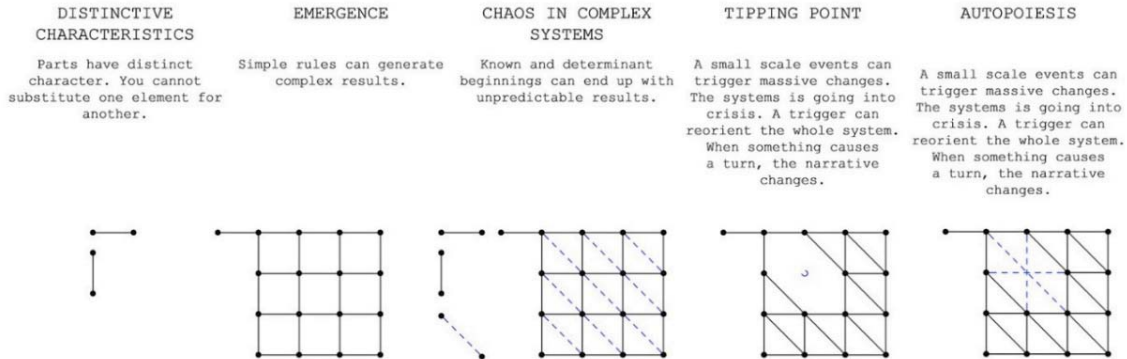

Figure 3. Key concepts of Richard Sennett's Open City Theory (source: Daniela Nunez, B.Arch graduate 2018)

The next structural element of the studio was to direct and infuse the use of design tools which could possibly facilitate these concepts. Architectural design software is not neutral so researching different tools and explorations were imperative. One of the concepts that ties all natural systems together is the fact of being alive. Students needed to embrace the concept of time and dynamism into their designs. This temporal shift of thinking is also key in our age of indeterminacy brought on by the Anthropocene.

It is imperative to make time for tool/making explorations, as generally there is so much pressure for students to produce, in a conventional sense, and so adding in more stochastic processes gives the option for priori and apriori design methodologies. The two main software programs explored were Processing [3] and various plug-ins for Rhino's Grasshopper [4] by McNeel, including Weaverbird, Kangaroo, Culebra, Heteroptera and Quelea; physics engines and agent-based modelers respectively (Figure 4 and 5).

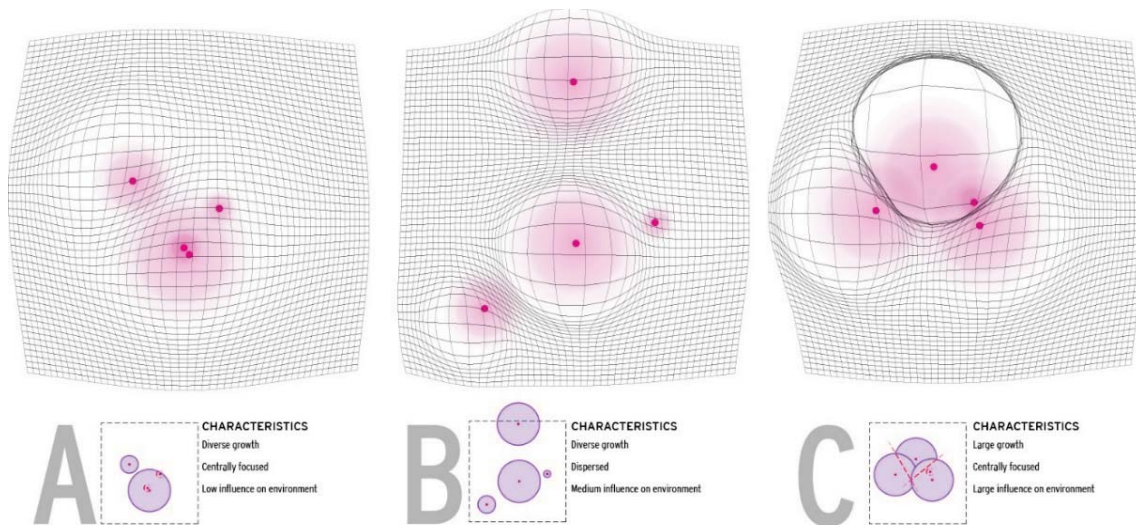

Figure 4. Example of work with jellum tool from Heteroptera plug-in (source: Di Ngo Le, B.Arch graduate 2018)



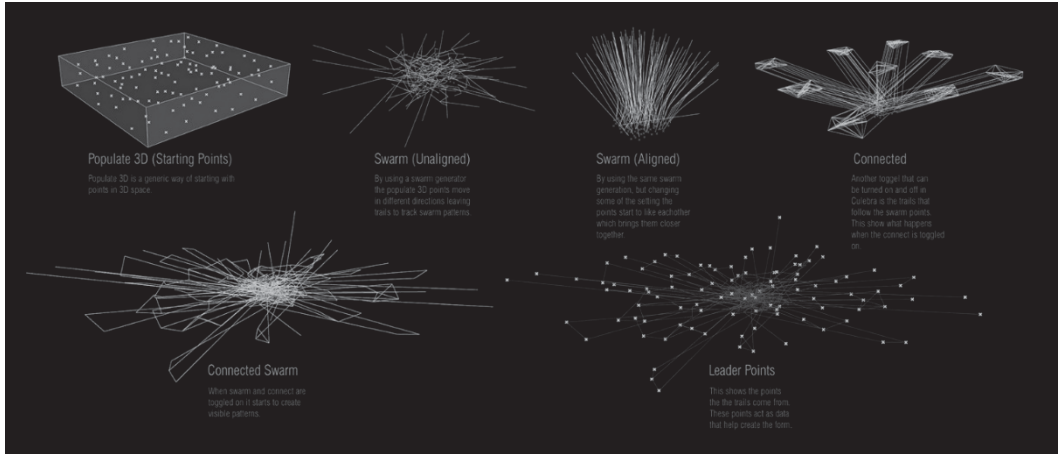

Figure 5. Example of work with Culebra plug-in (source: Connor Holden, B.Arch graduate 2018)

As stated earlier, it is important at each stage of the process for students to disseminate their learning/experiments in some form.

## Proposals

After these more abstract assignments, students were given a physical location for a design proposal; the city of Los Angeles. This led to another round of research as specific cultural aspects and GIS and environmental data needed to be incorporated. Depending on the student's prior knowledge and inter-disciplinary opportunities, this can be a whole research/new area in itself; the connection/integration of GIS and BIM. This is why it is important to have the more abstract, agent-based exploration first as the introduction of 'reality' can be overwhelming for some and is an ongoing design challenge, particularly in the area of incorporating live data.

The point was to use their previous knowledge to view site analysis through a different lens. Instead of just following a typical checklist of contextual analyses, it was encouraged to see less obvious relationships and to connect this with their previous work. These ranged from looking at the site through the lens of Subnatures (Gissen, 2009) to the dynamic mapping of water-flows and sources. Student Di Ngo Le continued his work on the Posthuman City, picking up the various elements mentioned as a lens to view the city; air, water, energy/fire, earth, sensing, moving, recycling, connecting, making and sensing (Figure 6).

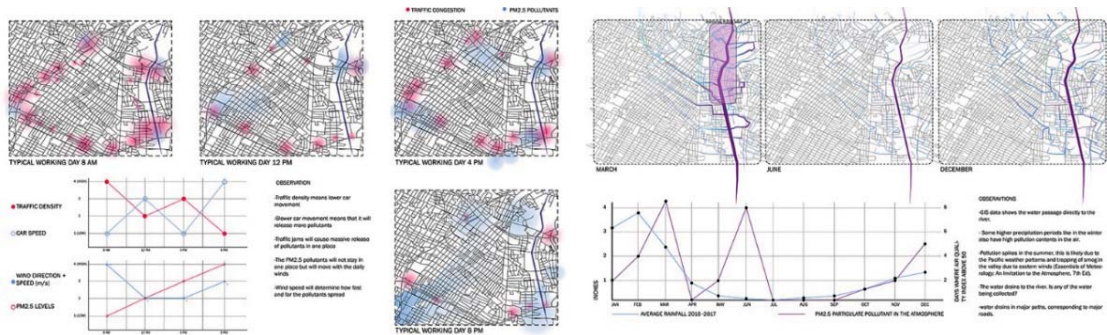

Figure 6. Posthuman Site Analysis, showing L to R; Air + Fire (Energy) and Water + Surface analysis (source: Di Ngo Le, B.Arch graduate 2018)

Another student, Jeffrey Moser saw the city as a "living and dynamic set of nodes and networks, which worked on various scales for different groups", he saw that industry, culture and individuals generally are zoned differently, with various connecting transportation networks (Figure 7).



Figure 7. Three types of networks relating to LA's transportation systems (source: Jeffrey Moser, B.Arch graduate 2018)

These transportation networks were sorted into the following three types of networks; centralized networks (rail lines), decentralized networks (highway system) and distributed networks (surface streets). The distributed system of the surface streets are by their very nature the most resilient and democratic networks, but are less efficient in certain areas and in this example are often slow and over-crowded. This study made him aware of the lack of connectivity of the parks and "greener" areas of Los Angeles, which led to a proposal, to provide an alternative hybrid network for the city for humans, new infrastructure and vegetation which would grow and adapt based on stimuli of density levels and social/cultural nodes throughout the city (Figure 8).

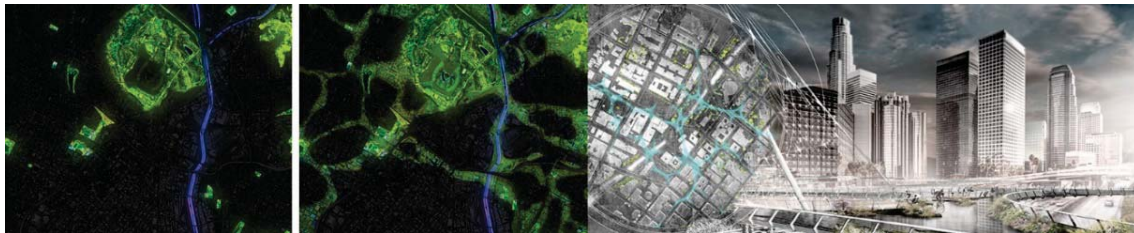

Figure 8. Alternative LA Network, before and after (source: Connor Holden and Jeffrey Moser, B.Arch graduates 2018)

Naturally some of the proposals were more speculative than others, with the necessary adaptability/change being achieved through various methods at various scales. Most worked at the urban scale though, where some chose to see their project as an intervention, a catalyst that would hopefully produce change and grow over time with feedback rather than a masterplan or top down piece of infrastructure. Many had hybrid forms of top down and bottom up systems, which fit in with the Deleuzian rejection of dichotomies. Diversity and multiplicity were embraced throughout, in terms of realizing, one size fits all is not appropriate, but there was also the realization that although agency was desired for humans (Figure 9) and other forms of life, there was not a desire for homogeneity of systems where everything was necessarily in balance or equilibrium in a traditional closed sense, but that it was about finding patterns between organisms and their environment, more as an inter-connected field instead of isolated objects. A couple chose to be more futuristic in their approach, incorporating assumed advances in protocell technology and/or programmable matter which would allow for a level of adaptability and response to environmental stimuli which more mainstream technologies could not allow for.



Figure 9. Adaptability options for Eco-Net project; sensing, moving, recycling, connecting and making + sharing (source: Di Ngo Le, B.Arch graduate 2018)

## Conclusions

Today we need to look at the implications of change and adaptability more than ever. In the past the built environment has had generations to adapt, emerge and integrate technological advances over generations. With global population growth and major sustainability problems we no longer have the luxury of endless amounts of time to correct our mistakes, we need to design systems and environments where we have factored these issues into the equation already, or at least try too.

A studio's work can always be critiqued, but feedback from the student's suggested that educationally the class was a success and the exposure to these issues and potential inclusive theoretical strategies will hopefully last a lifetime. There was still a tendency for the students to show final work in a typical static fashion, although at least most had some time-based images.

The goal was to move beyond reductive technical issues or realms of research, which performative design has almost become known for, but relate to aesthetics, ethics and philosophy to name a few of the realms contemporary architecture should also address/incorporate. Many of the built environment's recent past problems have been created through designs which were too simplistic and controlling, so incorporating more depth of knowledge will help move architecture beyond superficial form making or reductive technical solutions. As Branko Kolarevic (2015) recently wrote; "In short, much remains to be done: I would argue that change - and time as a design dimension in architecture - are far from being adequately addressed or explored theoretically, experimentally, or phenomenologically."

## References

- Gissen, David, *Subnatures: Architecture's Other Environments*, Princeton Architectural Press, New York, 2009.
- Jacobs, Jane, *The Death and Life of Great American Cities*, Random House, New York 1961.
- Leopold, Aldo, *A Sand County Almanac and Sketches Here and There*, Oxford University Press, New York, 1949.
- Scully, Vincent, *Architecture – the Natural and the Manmade*, St. Martin's Press, New York, 1991.
- Sergeant, John, *Frank Lloyd Wright's Usonian Houses*, Whitney Library of Design, New York, 1976.
- Zaera-Polo, Alejandro, "The Posthuman City: Immanent Urban Commons", *Architectural Design*, vol. 87, issue. 1 pp. 26-35, John Wiley and Sons, Oxford, 2017.

[1] <https://lsecities.net/media/objects/articles/the-open-city/en-gb/>



[2] <http://www.metropolismag.com/cities/why-architects-must-rethink-carbon-its-not-the-enemy-we-face/>

[3] <https://processing.org/>

[4] <http://www.grasshopper3d.com/>



The built environment as an extension of human biology:  
Alexander, Damásio, Bratton  
Diana Soeiro

## The built environment as an extension of human biology

Alexander, Damásio, Bratton

Diana Soeiro<sup>1</sup>

<sup>1</sup>*Nova Institute of Philosophy (IFILNOVA), Universidade Nova de Lisboa, Portugal*

<sup>1</sup>*diana.soeiro@fcsh.unl.pt*

**Abstract.** Along with architect Christopher Alexander (b. 1946), neuroscientist António Damásio (b. 1944) and philosopher Benjamin H. Bratton (b. 1968) we aim at present the built environment as an extension of human biology, having digital technology a key role. In order to clarify under which terms does this extension takes place, a new approach to theory of form is necessary, and the concepts of geometry, artificial, natural, consciousness, geography, city and space need to be addressed. Mathematics can prove to be an effective moderator helping us design an organizational system that better suits our mind and body's experience of space nowadays.

**Keywords.** *Theory of Form; Extended Consciousness; Urban Theory; Philosophy of Space; Technology.*

### General

Geometry, is a key element to identify patterns that both define our physical body and a given built structure. Can we use our biological pattern to better design our urban built environment? How can the built environment better reflect and envelop the human body's geometry? The surrounding environment shapes us but, also, we are the ones shaping our environment and if on one hand, our surrounding environment is rapidly becoming more urban, on the other hand, our living experience of our body is becoming less physical and more virtual.

But what both urban environment and body seem to have in common is that they are going through a process of virtualization through digital technology. Increasingly digital cities match increasingly digital bodies, creating a layer that seems to envelop both cities and bodies. How can the design of future cities better harmonize both and what use should be made of technology in order to achieve it?

We identify three contemporary authors whose work represents a crucial contribution so we develop solutions that are sustained by key principles: Christopher Alexander (b. 1946), António Damásio (b. 1944) and Benjamin H. Bratton (b. 1968).

Alexander, Austrian architect and theorist, took the study of urban morphology as the study of the evolution of a body structure, similar to a living organism, claiming that patterns are not enough to describe urban morphology dynamics and that we need a "morphogenetic" understanding of the formation of the built environment.

Damásio, Portuguese-American neuroscientist, has presented the concept of "extended consciousness" in order to explain how our mind plays a crucial role in the way our body relates to the surrounding environment, defining our living experience as a limbo between real and imagined.

Bratton, recently used the concept of "the stack" to reflect on the growing complex intertwining of physical and surrounding environment where technology plays a key role, both in the shaping of cities and the shaping of our minds.





Using these three authors as main references, we design a multidisciplinary framework that allows us to better understand that geometry is key to harmonize city's and body's evolutionary path and that ultimately, the geometry of nature has a leading role in the design of adequate and enveloping built environments.

We claim that the key principles to establish the parallel between the body and the surrounding built environment is an understanding of geometry that is sustained not in a causal, systematic framework but in a relational, network diagram instead. That implies a new concept of theory of form where built environment is an extension of human biology, mediated by technology.

## Urban Growth: physical and virtual

According to a United Nations' report (UN-Habitat, 2016: 196) the world level of urbanization in 1995 was 44.7% and it is expected to reach 58.2% in 2025. The fastest growth rate will take place in 'least developed regions' and 'upper-middle-income countries'. Considering that this refers to a thirty years time span, an increase of around 13% sounds fast-paced. But when compared with the numbers on urban population growth, the speed is startling. In 'developed regions', considering once again the 1995-2025 period, the increase is not that significant (from 860,171 millions to 1,034,150 billion), but judging on the available data, we can observe a pattern: the less developed a country is, the more likely it is to experience a very rapid urban growth of its population, up to three times more in 2025, than in 1995, with, for example, 'low income' countries going from a population of 133,543 to 397,055 millions.

Considering the same time frame, overall, in 'less developed regions', the urban population is expected to double to 3,671,623 billions. Worldwide, 4,705,774 billion people will be part of the urban population.

This future scenario is not far away and it is expected to come true in around twelve years. This means that many of the projects that will enable to shelter almost five billion people worldwide, are either waiting for its approval or at to say the least, in the making. Many, of course are already under way.

What new challenges can we expect of such a fast-paced urban growth both to the way we experience space and to the new geographies that are being created?

At this point, it is relevant to make a distinction between how we should understand growth in 'developed countries' and 'least developed countries'. Though urban growth is slower in 'developed countries' when it comes to the creation of new psychical structures, there are two tendencies that are relevant to understand a different focus of urban growth: rehabilitation and smart cities. On one hand, the reconversion and rehabilitation of older structures in order to serve contemporary needs. The ability to adapt is crucial, due to the lack of space in cities that are already structured and settled according to specific principles that are perceived as valid. On the other hand, the connection between different aspects of urban life expands the city, virtually, through widespread digital technology use, both by the public administration and most of its population.

In 'least developed countries' the urban growth should be understood in its traditional, psychical sense, where more structures will come to occupy physical territory, on the ground itself — instead of in 'the cloud'.

Being geometry a part of mathematics, is it possible to determine a pattern of urban growth — concerning the one that we are experience now and the one we will soon experience in 2025? Would there be an advantage in establishing a geometrical urban growth pattern? If so, according to which model?

Thinking of the different patterns cities can present, from a bird's eye view, like Paris or Venice, for example, in order to better try to answer the questions we just posed, we will reduce the scale of elements, translating the same questions from a spatial planning perspective, to an architecture

perspective. This will have the added advantage of enabling us a softer transition between three key elements: body, built environment and surrounding environment.

Having clarified the different types of growth that are at stake, whether we refer to 'more developed countries' or 'least developed countries', let us now clarify the understanding of geometry that is at stake in this paper.

## Geometry is not symmetry

In the West, there is a tendency to understand geometry under the principle of symmetry (reflective, rotational, helical, etc). In the East, particularly in Japan, geometry is understood under the principle of movement, closer to what we would call dynamic geometry. In the Japanese language, 'symmetry' is usually translated, scientifically, as *taishō* or *taishōsei*. But recently, it was proposed that in order to convey the proper meaning of how symmetry is understood in Japan, the word *katachi* should be used instead. Though it does not translate as scientifically 'symmetry' as understood in the West, being *katachi* a traditional word, it unveils the recently lost link (in the beginning of the XXth century) between art and science, which were once, one. Additionally, according to Tohru (et al, 1996: 3) *katashi* means basically: form, shape, figure and pattern but also appearance, ceremony, composition, evidence, formality, format, formation, frame, framework, indication, manner, mark, model, mold, omen, outlook, prospect, prototype, routine, skeleton, sign, situation, size, structure, style, symptom, texture, trace, and usage, among others. The character for *katachi* is also used in Japanese for "metaphysical " and "physical", being associated with many fields of human activity.

Tohru (et al, 1996: 3) refers the different geometries at stake in the traditional Western garden and in the Japanese garden, where the geometry is not as obvious though it is definitely there.

To his example we add two more. The *ukiyo-e* by Hokusai, *The Great Wave*, where in



Figure 1. Hokusai, *The Great Wave* (1829–1832) [1]

the background we can see Mount Fuji and on the left a big wave about to crash on it, being the potentially threatening event enhanced visually by the claw-shaped edges of the waves. The image,

taken as a whole, embodies a perfect sense of symmetry, which clashes with the chaotic tsunami-like event depicted. The balance of the forms depicted is in direct tension with the chaos of the content, which contributes to portray an image with an unresolved tension. The tension would be lessened if the geometry of the image were symmetrical, in the western sense. The hidden geometry of the image makes it one of the most praised and well-known works by Hokusai.

A second example, is that of *ikebana*, the art of flower arrangement in Japan where geometry plays a key role and the understanding of symmetry is far from that of the West. Balance is aimed between vase, choice of flowers and its arrangement, framing of the vase within a specific room, in a specific part of the room.



Figure 2. Maiko & New Years' ikebana arrangement, c. 1910 [2]

At this point, it is now clear why is it that our visual understanding of geometry should go beyond geometry as traditionally understood in the West, encompassing a more extensive significance, as the one embodied by the concept of *katashi*, where a geometrical pattern does not translate necessarily in a geometric symmetry. Therefore, from now on, we will establish as a key



concept in this paper that of 'pattern' instead of 'geometry' or 'symmetry' in order to be closer to the understanding of symmetry expressed by *katashi*.

## 'Artificial' and 'natural' in the context of digital technology

In the context of a fast-paced urban growth where it seems hard to establish or define any model in order to identify an organized pattern, another distinction that is relevant, is the one between 'artificial' and 'natural' addressed sometimes, also, as 'artifice' and 'nature'.

French philosopher Georges Simondon (1924-1989) was one of the first to reflect on the interplay between man and technology, man and machine and in what way would it impact the world, mankind's lifestyles but also man's ontology (what man is).

Simondon thinks that the digital age brings radical challenges to theory of form being one of the key subject that needs to be re-thought. One of the consequences of the changes brought by the digital age is that the limit that once separated our concepts of 'nature' and 'artifice', blurs. Does it blur to the point where one concept replaces the other? Even if that is so, which understanding should we have of the one which stands?

According to Simondon, a technical object is produced and yet it can be said to be "close to the mode of existence of natural objects" when it is concretized. (...) [A]n artificial object whether it is produced by man or by nature has its conditions of functioning related with an exterior environment [milieu] that regulates it, from where it is cut. Contrary to an object close of the mode of existence of natural beings, it incorporates in its functional systematic the milieu that regulates it, the "associated milieu". (Guchet, 2010: 186-187)

This means that the distinction between 'artifice' and 'nature' does not rest on who/what has produced the object but rather on whether it harmonizes with the milieu or not. If it does, it will appear as natural, if it does not, it will be perceived as artificial.

Decades later, French philosopher Gilles Deleuze (1925-1995), strongly influenced by the work of Simondon, states: "Artifice is fully a part of Nature" (Deleuze, 1988: 124). Deleuze too had a strong interest in theory of form having stated that his final project with Guattari would be "une nouvelle philosophie de la nature, au moment où toute différence s'estompe entre la nature et l'artifice" (Deleuze, 1988a, 25).

Deleuze has re-defined epistemologically theory of form, in the field of Philosophy, presenting us a model that would better allow us to think the blur between 'artifice' and 'nature' which in other words means, as he himself proved to be aware, to rethink the concept of nature.

The need to re-shape and address the concept of nature is still present today, due to ongoing technologies advances in the last decades and a surrounding environment that changes at a fast-pace, growing in its complexity. Is it possible to create a model that help us shape and understand the new shape that the blur between natural and artificial is bring us, and updating, almost daily? How can we keep up and how does that affect the way we design and organize space and structures that envelop us?

By considering simultaneously the work of architect Christopher Alexander (b. 1946), neuroscientist António Damásio (b. 1944) and philosopher Benjamin H. Bratton (b. 1968) we will attempt an answer to those questions.

## Christopher Alexander: a morphogenetic understanding of form

The tree-like structure as an organizational model was embodied by what became known as the Metabolist movement in Japan, which fully came to life with architect's Kenzo Tange (1913-2005) approach to Tokyo Bay, in 1961. The metabolists wanted to develop complex structures "yet were always constrained by what was essentially a hierarchical and ultimately simplistic scheme of trunk, branch and leaf components" (Asada, 2001, 1010). This kind of approach is not exclusive of



Japan, nevertheless a reference to the Metabolist movement is relevant because as a reaction, a post-metabolist program emerged aiming to develop a more organic system capable of dynamic and complex growth, that became known as “neo-vitalism”. This approach is embodied by Deleuze’s philosophical approach but even before Deleuze, Austrian architect Christopher Alexander stood up against the tree-like model as the privilege way to organize complex structures in a ground-breaking essay “A City is Not A Tree” (1965). (Asada, 2001: 1009)

To Alexander, any complex scheme can be organized logical and simply. To the tree model, he proposes the notion of spontaneous city, both in its formation and growth. Tree-like models create artificial cities whereas lattice-like models create natural, spontaneous cities. The architect should plan aiming to stimulate spontaneous growth by overlapping layers, close knitting every set. The overlapping model of growth is essentially ahierarchical and modelled in a network-like structure. Like Asada states (2001: 1010), Giles Deleuze and Felix Guattari would, ten years later, also describe a ahierarchical system, to which they called, rhizome.

In 1977, Alexander publishes *A Pattern Language: Towns, Buildings, Construction*, which embodies his background studies both in Architecture and Mathematics, having identified 253 design patterns, used throughout times to solve urban morphology related problems. The book aims to provide independent patterns that should be taken as basic elements that can be combined according to the planner’s need in order to form unique clusters that present in a simple way the most adequate solution to a specific site. In that sense, each pattern can be combined with any other pattern or patterns, presenting itself as a language where multiple combinations are possible. The 253 patterns are a simplification exercise in order to better answer to complex demands, more spontaneously according to a network-like model being Alexander acknowledged as an architect and a computer software pioneer.

More recently, in 2004, Alexander wrote *The Nature of Order: An Essay on the Art of Building and the Nature of the Universe* (2004) where he states that patterns are not enough to describe urban morphology dynamics and that we need a *morphogenetic* understanding of the formation of the built environment. In order to better grasp the growth of cities, and having worked for a long time with the, at times, polemic mathematician Nikos A. Salingaros, Alexander claims the use of fractal theory and biology — hence his name is associated with the ‘Morphogenetic School’. This school was formed by Alexander’s long time collaborator Salingaros and claims that urban development is a computational process similar to that of cell growth in an organism, and the unfolding of these processes produces the urban landscape and its typologies. Two main characteristics are at stake: morphogenesis, the biological process that causes an organism to develop its shape and emergence, the phenomenon whereby larger entities arise through interactions among smaller or simpler entities such that the larger entities exhibit properties the smaller/simpler entities do not exhibit.

Salingaros provides a crucial distinction between self-organization and adaptivity, that allows us to better understand what is at stake and how mathematics relates to nature, spatial organization models. Says Salingaros: “Any natural pattern that shows organization on every level of magnification is the product of some mechanism of self-organization. (...) Whereas self-organization is driven primarily by internal constraints, adaptivity is driven by external constraints, so the system has to be open. A system may self-organize but not be adaptive; it is independent of its surroundings — that is, closed. A complex fractal need not adapt to anything outside its own symmetry. In that case, it develops the same intricate pattern regardless of where it grows. An adaptive system, on the other hand, whether it self-organizes or not, develops according to input from its surroundings. (...) The key to adaptivity is having a mechanism for feedback. Without feedback, there is no way of incorporating ambient information into the algorithm for growing a complex system. Both the brain, and living structure, depend for their function on an enormous amount of feedback. Dead matter has no feedback. (...) An adaptive design evolves according to how it satisfies requirements for its use. It adapts to a set of conditions; usually having to do with its relation to internal and external forces.” (Salingaros, 2004)





Both Alexander and Salingaros stand for a morphogenetic approach to form where mathematics and a dynamic understanding of geometry, based both on a scientific and intuitive approach, provide the main input, similar to the kind of approach taken in computer software design.

But how can we make better sense of the internal and external forces that shape and define form nowadays, where physical and virtual elements constantly interplay? This is when Damásio's 'extended consciousness' concept may be helpful.

## António Damásio: extended consciousness

In Damásio's own words, we provide a brief definition of extended consciousness: "Extended consciousness goes beyond the here and now of core consciousness, both backward and forward." (Damásio, 2000: 195) This means that extended consciousness has duration, it has the ability to sustain over time. But what does it do exactly?

"The secret of extended consciousness is revealed in this arrangement: autobiographical memories are objects, and the brain treats them as such, allows each of them to relate to the organism in the manner described for core consciousness, and thus allows each of them to generate a pulse of core consciousness, a sense of self knowing. [It is] the ability to learn and thus retain records of myriad experiences, previously known by the power of core consciousness [and] the ability to reactivate those records in such a way that, as objects, they, too, can generate "a sense of self knowing," and thus be known." (Damásio, 2000: 196,197)

Therefore, in a given moment, our working memory deals with two types of objects, "the object being known and the objects whose display constitutes our autobiographical self (...). Once autobiographical memories are formed, they can be called up whenever any object is being processed". (Damásio, 2000: 197)

In the context of a growingly complex urban environment, our ability to experience artifacts as natural, strongly depends on the ability given by our extended consciousness.

As more layers are added within the surrounding urban environment, where physical and virtual structures intertwine to the point where we experience them simultaneously, as if in an intermediate space where boundaries are blurred, the more is demanded from our extended consciousness. The amount of information that is required to be handled by extended consciousness is rapidly increasing, along with the accelerated urban growth, putting both our extended consciousness and our autobiographical self to the test. How many objects is a mind able to store or handle, simultaneously? How does the pressure on our extended consciousness and autobiographical self by urban layers of objects, affect our self knowing and our sense of identity? How does it affect our ability to orientate ourselves and move around in space?

It is no coincidence that part of the technology content perceived as necessary to inhabit the urban environment includes, mapping related software and apps that help to promote physical and mental health. There is a sense of excess of information, on one hand, and on the other, a sense of pressure where the interior forces of self-organization are in strong tension with exterior forces that ask us to adapt.

As Salingaros stated when referring to cities, not also cities but also our minds, should function according to the principles of an adaptive system. Adaptivity is having a mechanism for feedback. But due to the size and large scale of our future cities, the feedback mechanism required can be too heavy and too fast-paced for our minds. With time, and practice, we can get used to it, adapt, and keep up. But at what price? What will be different about us during and after the process? Are we aware of what part of ourselves are we dismissing?

What seems to be evident is that man makes technology and in that sense, we seem to have imprinted a similar biological dynamics to 'the machine', which in the last decades has been rapidly



becoming our surrounding environment, enveloping us, as cities grow worldwide. What is 'the machine' and can we define it?

## Benjamin H. Bratton: "the stack"

To 'the machine' we just referred to at large, Bratton defined it under the concept of "the stack" having presented a detailed description of its content (Bratton, 2016). To put it briefly, "the stack" is composed by several layers that go from large/physical scale to small/ virtual scale: earth layer, cloud layer, city layer, address layer, interface layer, and user layer. The main idea, taking Bratton strong influence from the work of Deleuze, is that the way we experience space has rapidly change over the last decades, since the emergence of digital technology. The geography and the limits that were once traced on maps, where continents and countries had frontiers that actually stood for something, nowadays, have become abstract and volatile.

Digital technology has imprinted a dynamic that self-imposes in all regions, from the geography of earth (earth layer) to the geography of self (user layer).

As for scale, a key concept in space related sciences, it is also confusing. If on one hand we can say that our spatial scale was reduced from country to 'user', on the other hand the multiple spaces our 'user' enables us to access and the simultaneity of spaces that can be reached through the 'user layer', actually multiplies infinitely the space that is available. It is as if the more the physical scale is reduced, the more the virtual scale is extended. "the stack" is the apparently infinite juxtaposition of layers and elements that our extended consciousness seems to have to be able to handle, by adapting and learning fast. How does this affect the way we design and conceived cities and structures? Under which principles should they be designed? Under the psychical principle or under the virtual principle? Is it possible to find a balance between both? What is the form of the city of "the stack"?

## A new concept of theory of form

The question that we are approaching here is simultaneously epistemological and normative. How should we think form and what understanding can we have of form nowadays? What role does the link between mathematics and architecture have in order to help us answer these questions?

According to Alexander, Damásio and Bratton, our human biology dynamics seems to extend to the our surrounding environment. At the same time, due to the strong part that digital technology plays nowadays, we seem invited to adapt to its force exerted from the exterior and in order to exert our adaptability, we should give feedback.

The ability to adapt, along with the ability to react describes one of the basic principles of Alexander and Salingaros "morphogenetic" approach. The network like structure, opposed to a tree-like structure, aims at promoting the structure's flexibility to, spontaneously, integrate new objects.

According to Damásio's framework, we would assume that more and more, our core consciousness becomes a larger part of our extended consciousness, demanding us to handle large amounts of information simultaneously, leaving us, curiously enough, with a decreased sense of identity and less self knowledge. Past and present blur and 'right now' seems to occupy most of the mind's space. (Notice that we said 'right now' instead of 'now' to avoid an association between 'right now' with Eastern Buddhism's 'now' where the present moment is a progressive conquest. By using the term 'right now' we aim to describe the negative expression of Buddhism's 'now', representing a low conquest, self knowledge-wise).

If Bratton's "the stack" becomes prevalent and if urban growth as well as its population, rapidly increase, how to conceive a traditional sense of space where limits and frontiers play a key defining role?



Adding to this, the phenomena of an increasing number of forced migrations, voluntary global nomadism, and increased digital technology portability, is it possible that architecture's main element is now the human body? Should architecture become an exercise of how to envelop the physical body? Does it make sense to conceive big structures that envelop large amounts of people or do they promote a sense of disconnection with the physical space? It seems that people seem to feel unprotected and disconnected from large physical spaces and feel welcomed and enveloped in virtual space, a place they can call their own, as 'user'. What to make of physical public space? Was it fully deviated to the virtual 'user'? Is the geography of 'user' replacing physical space?

The speed to which urban growth is taking place, propelled by digital technology, is impressive. In this case, though an urban planner and architect's job is to anticipate and prepare the future, the prevalent presence of digital technology in the way we experience space, seems to be taking over. Are we being trapped by circumstances? Do urban planners and architects have a real say in the design and future of cities?

We end with a quote from Salingaros (2004) that expresses the basic terms under which cities can be designed, where mathematics has a positive influence as moderator: "the traditional built environment is a product of a collective intelligence (such as shown by social insects) applied to deepen the human understanding of form. Adaptive top-down and bottom-up design methods were explained with reference to results from complexity theory. An old misunderstanding, which considered top-down and bottom-up methods to be mutually contradictory, was cleared up — in fact, as long as they are truly adaptive, the two methods are mathematically equivalent".

## References

Alexander, Christopher, *Notes on the Synthesis of Form*, Cambridge, MA/USA: Harvard University Press, 1964 (1971).

Alexander, Christopher, "A city is not a tree" in *Architectural Forum* 172 (April/ May), 1965; also in *Ekistics* (June 1967) 23 (139) and in Gwen Bell and Jaqueline Tyrwhitt (eds.) *Human Identity in the Urban Environment* (pp. 401-28). Harmondsworth: Penguin Books, 1972.

Alexander, Christopher, Sara Ishikawa, Murray Silverstein, with Max Jacobson, Ingrid Fiksdahl-King, Shlomo Angel, *A Pattern Language: Towns, Buildings, Construction*, New York: Oxford University Press, 1977.

Alexander, Christopher, *The Nature of Order: An Essay on the Art of Building and the Nature of the Universe*, 4 vols, Berkeley, California: The Center for Environmental Structure, 1980 (2002–2005).

Altamirano Marco, *Time, Technology and Environment: An Essay on the Philosophy of Nature*, Edinburgh University Press: Edinburgh, 2016.

Asada Akira, "Untitled" in Gary Genosko (ed.), *Deleuze and Guattari: Critical assessments of leading philosophers*, pp. 109-114, Routledge: London and New York, 2001.

Bratton, Benjamin H., *The Stack: On Software and Sovereignty*, The MIT Press: Cambridge, MA, 2016.

Damásio, António, *The Feeling of What Happens: Body and Emotion in the Making of Consciousness*, Mariner Books: Boston, MA, 2000.

Deleuze, Gilles and Félix Guattari, *A Thousand Plateaus*, Trans. Brian Massumi. Minneapolis, MN: University of Minnesota Press, 1988.

Deleuze, Gilles, *Spinoza: Practical Philosophy*, Trans. Robert Hurley, San Francisco: City Light Books, 1988.



Deleuze, Gilles, Interview in *Magazine Littéraire* 257 (September), 1988a.

Guchet, Xavier, *Pour un humanisme technologique: Culture, technique et société dans la philosophie de Gilbert Simondon*, Paris: PUF, 2010.

Salingaros, Nikos A., "Architecture, Patterns, and Mathematics" in *Nexus Network Journal* vol. 1 (1999).

Salingaros, Nikos A., "Design methods, emergence, and collective intelligence" in *Katarxis*, 3, September, London: UK, 2004. [http://www.katarxis3.com/Salingaros-Collective\\_Intelligence.htm](http://www.katarxis3.com/Salingaros-Collective_Intelligence.htm)

Tohru, Ogawa, Husimi Ködi, Miura Koryo, Masunari Takashi and Nagy Dénes, "Introduction: The concept of a Symposium", in Ogawa, Tohru and Koryo Miura, Takashi Masunari and Nagy Dénes (ed.) , *Katachi U Symmetry*, pp. 3-6, Springer: Tokyo, 1996.

UN-Habitat, *Urbanization and development - Emerging Futures: World Cities Report 2016*, United Nations Human Settlements Programme (UN-Habitat): Kenya, 2016.

[1][https://upload.wikimedia.org/wikipedia/commons/a/a5/Tsunami\\_by\\_hokusai\\_19th\\_century.jpg](https://upload.wikimedia.org/wikipedia/commons/a/a5/Tsunami_by_hokusai_19th_century.jpg)

[2] <http://www.oldtokyo.com/ikebana-flower-arrangement-c-1910/>

ORGANIZATION:



CO-ORGANIZATION:



SUPPORT:



SPONSORS:



PARTNERS:



MEDIA PARTNERS:



ISBN 978-989-8862-24-2



9 789898 862242



KINESISTEM17.WEBBLY.COM